



Specification

Fri Apr 20 16:43:05 CEST 2018

SelfCookingCenter® SCC 62 E (6 x 18 x 26 inch/12 x 12 x 20 inch)



Capacity

- Six (6) full-size sheet pans (18"x26") or Twelve (12) Steam table pans (12"x20"x2.5") GN1/1
- Removable, swivelling hinging rack
- Vertical distance between rails 2 5/8" (68 mm)

Standard Features

- Electrically heated table device for automatic cooking of meat, poultry, fish, side dishes, vegetables, egg dishes, desserts, bakery products and for automatic rethermalization
- Mixed loads with individual supervision of each rack, depending on type, load amount, and the number of door openings
- Optical rack signaling function
- LED cooking cabinet and rack lighting - energy-saving, durable and low-maintenance
- Optical rack signalling function
- Rear-ventilated triple-pane cooking cabinet door, two hinged inside panes (for easy cleaning) with a special heat-reflecting coating
- Combi-steamer according to DIN 18866, DIN 10535 for selective use of steam and hot air, separately, sequentially, or combined
- Integrated Ethernet and USB port to connect to a cloud based system for administration of cooking processes, management of HACCP and service data and remote control
- No water softening system or additional descaling is necessary
- 2-Year parts and labor warranty
- 5-Year steam generator warranty
- No-charge 4-hour RATIONAL certified chef assistance program
- Core temperature probe with 6 measuring points, including positioning aid - automatic error correction in case of incorrect positioning
- 1% - accurate regulation of moisture, adjustable, and retrievable via the control panel
- Combi-steamer mode °F/(°C): steam: 85 to 265/(30 to 130), hot air: 85 to 575/(30 to 300), combination: 85 to 575/(30 to 300)
- Individual programming of at least 1,200 cooking programs with up to 12 steps transferable via USB
- Hand shower with automatic retracting system
- Moisturising in 3 steps of °F/(°C) 85 to 500/(30 to 260)
- High-performance fresh steam generator, pressureless, with automatic filling and automatic decalcification
- Dynamic air circulation in cooking cabinet with reversing wheel fan with 5 fan speeds, programmable
- Integral, maintenance-free grease extraction system

- Single water connection as shipped, can be split connection for treated and untreated water
- Turbo fan cool down function
- Automatic adaptation to the installation location (elevation)
- Height adjustable feet +- 3/8" (10 mm)
- 304 (DIN 1.4301) stainless steel material inside and out
- Seamless interior and with rounded corners
- Demand-related energy supply
- 5 programmable proofing stages
- Automatic, pre-selected starting time with adjustable date/time
- Delta-T cooking
- UL listed as Commercial Cooking Appliance with Integral Systems for Limiting the Emission of Grease-laden Air

Operation

- Digital, graphically supported overview of the current cooking chamber climate, review and forecast as well as repeat and change options at the end of the cooking process
- Remote control function for appliance using software and mobile app
- Control second unit from the main unit (units must be connected via ethernet or network)
- Real-time information about automatic adjustments on current cooking process
- Self-learning operation, automatically adapts to actual usage
- Intelligent energy-management system controls the energy and airflow, fully automated
- Record mode – determination of the ideal cooking process for calibrated products using the core temperature probe for subsequent use without a core temperature probe, with automatic consideration of the load quantity
- Self-configurable, user-specific operating display 8.5" TFT color monitor and touch screen with self-explanatory symbols for ease of operation
- Application and user manuals can be viewed on the unit display for the current actions

Safety features

- Detergent and Care Tabs (solid detergents) for optimum working safety
- HACCP data output and software update via the integrated Ethernet and USB port
- Safety temperature limiter for steam generator and hot-air heating
- VDE approved for unsupervised operation (e.g. overnight cooking or cleaning)
- Maximum rack height 5 1/4 ft./1.60 m when original stand is used
- Integral fan impeller brake
- Door handle with right/left and slam function

Cleaning and Care

- Self-cleaning and care system for cooking cabinet and steam generator, regardless of the water pressure supplied
- 7 cleaning stages for unsupervised cleaning and care - even overnight
- Automatic cleaning and descaling of the steam generator
- Automatic cleaning prompts indicating the cleaning stage and volume of chemicals in relation to the level of soiling
- Soiling and care status are displayed on the monitor
- Diagnostic system with automatic service notices displayed
- Self-test function for actively checking unit's functions
- 100% biodegradable Cleaner and Care tabs

Ventilation approvals

- This appliance conforms to the EPA 202 test in accordance to the ANSI/NFPA 96 "Ventilation Control and Fire Protection of Commercial Cooking Operations" Refer to UL Listing KNLZ.E148536 (America) or KNLZ7.E148536 (Canada).

Approval/Labels





Specification

SelfCookingCenter® SCC 62 E (6 x 18 x 26 inch/12 x 12 x 20 inch)

ConnectedCooking



For proper usage of ConnectedCooking a network socket according to RJ45 has to be provided. For optimal performance a cable-bound connection with a data rate of at least 10 Mb/s is the preferred connection. Alternatively W-LAN connections with appropriate W-LAN adaptors can be used.

Combi-Steam mode



Steam °F/(°C) 85 to 265/(30 to 130)



Hot air °F/(°C) 85 to 575/(30 to 300)



Combi °F/(°C) 85 to 575/(30 to 300)

iCookingControl - Automatic cooking



7 application modes for meat, poultry, fish, side dishes, egg dishes, desserts, baked goods and Finishing® (rethermalization)

HiDensityControl®



Highest steam saturation, and dynamic air mixing for perfect and even cooking

Efficient CareControl



Efficient self-cleaning CareControl recognizes soiling and scale and removes it

iLevelControl



Mixed loads with individual monitoring of every rack depending on the quantity of the load as well as the number of door openings.

Technical Specification

Dimensions	Width	Depth	Height
Exterior	42 1/8" (1,069 mm)	38 3/8" (976 mm)	30 3/4" (782 mm)
Incl. Vent/Handle	-	40 7/8" (1,038 mm)	32 3/4" (832 mm)
Shipping	45 5/8" (1,160 mm)	44 1/8" (1,120 mm)	39 3/8" (1,000 mm)

Weight

Max Per Shelf	66 lbs
Max Load Size	132 lbs
Net	327 lbs
Shipping	396.5 lbs

Size	Electric. 60 hz	Breaker	Cable connection	Running Amps
62	208V 3 PH	70A	#3	61.4 amps
62	240V 3 PH	80A	#3	70.8 amps
62	480V 3 PH	40A	#8	31.5 amps
62	440V 3 PH	35A	#8	29 amps

Not supplied with cable connection. Use copper wire only. 3Ph 4-wire system (3 wire w/ ground)-dedicated 3 pole circuit breaker required. 1 Ph L1, L2, G-dedicated 2 pole circuit breaker required. 208 v is field retrofittable to 240v, 480v is field retrofittable to 440v. Special voltages available upon request. Do not use fuses. Supplied with an external data interface (splashwater proof LAN socket RJ45).

Thermal load and airflow requirements

Latent	958 W
Sensible	1236 W
Unit free standing	26945 ft³/h
One side against a wall	16986 ft³/h
Noise values	65 dBA

Clearance Requirements

To facilitate servicing, we recommend leaving a 18"-20" (450-500 mm) gap on the left-hand side of the unit. If there is not 18"-20" (450-500 mm) left side clearance available, provisions for moving the unit or appliance to the left for service access must be made. These include, but are not limited to, having quick connections (water, gas, etc.) and lengthened electrical connections with flexible cords. If there are no external heat sources acting on the unit, there should be a minimum gap of 2" (50 mm) to the left, right, and back of unit. If a high temperature heat source is on the left side of the unit, the left-hand gap must be a minimum of 14" (350 mm). This gap may be reduced to 2" (50 mm) by using a heat shield (see options). Recommended clearance from unobstructed rear exhaust pipes and any surface collecting grease or flammable material; 16" (400 mm) gas, 10" (254 mm) electric. It is recommended to have a hood overhang of 6" (150 mm) to 18" (450 mm) at the front of the unit and 6" (150 mm) on the side if installed at the end of the cooking line. Please refer to the Installation Manual for further technical data and for instructions on installation and setup. Installations must comply with all local electrical, plumbing, and ventilation codes.

Connected load electric

Hot air connection:	21.6 kW
Steam connection:	18 kW
Connected load electric:	22.1 kW

Water Requirements

Connection	3/4" GHT
Supply	Minimum 1/2" ID Drinking Quality Cold
Pressure	21-87 psi (1.5-6 bar)
Average Treated Water Consumption	2.2 gal/h
Min/Max Flow Rate	3 gpm/6.6 gpm
Water Drain	2" OD (50 mm) hub

Connect only to 2" (XS = 1 5/8") high-temperature resistant pipe. Water discharge temperature can be field adjusted to meet section 701.7 of the International Plumbing Code. Contact RATIONAL for back flow recommendation.

Water Quality

Untreated water can be 0 to 24.5 gr/gal (0 to 420ppm) hardness. We do not recommend treated water hardness < 5 gr/gal (86ppm) because the water could be corrosive. Sodium ion exchangers are not recommended; H+ Ion exchange systems are recommended. Water that does not meet the following minimum standards will require the proper conditioning.

Contaminant	Water Requirements	If > than recommended
Sand/Particles	< 15 µm	Particle filter
Chlorine (Cl2)	< 0.12 gr/gal (0.2 ppm)	Active carbon filter
Chloride (Cl-)	< 4.68 gr/gal (80 ppm)	RO or deionization

RATIONAL USA Inc.

1701 Golf Road, Suite C-120, Commerce
Rolling Meadows, IL 60008
Toll Free: 888-320-7274, Fax.: 847-755-9583

Visit us on the internet: www.rationalusa.com

We reserve the right to make technical improvements



Specification

Fri Apr 20 16:43:05 CEST 2018

SelfCookingCenter® SCC 62 E (6 x 18 x 26 inch/12 x 12 x 20 inch)

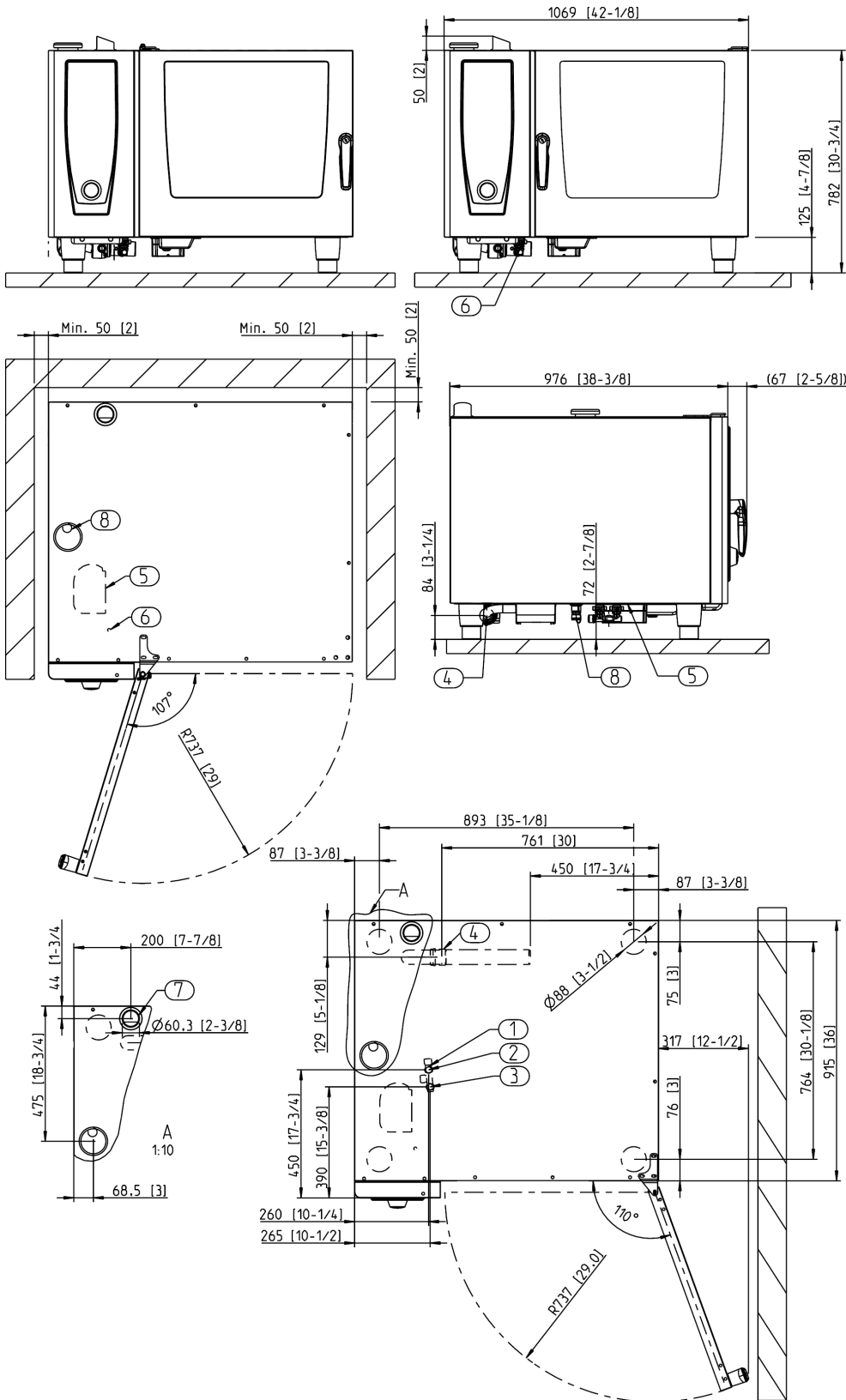

1. Common water supply (cold water) "Single" water connection as shipped 2. Water supply cold water / condensate "Split" water connection 3. Water supply cold / Treated "Split" water connection 4. Water drain 5. Electrical connection wire entrance 6. Chassis Ground connection 7. Steam Vent pipe DN 2 3/8" / 60 mm 8. Splashwater-proof Ethernet socket RJ45; minimum distance 2" / 50 mm Left side clearance 20" recommended for servicing of unit without the ability to move unit while connected. Measurements in mm (inch)



Specification

Fri Apr 20 16:43:05 CEST 2018

SelfCookingCenter® SCC 62 E (6 x 18 x 26 inch/12 x 12 x 20 inch)

ELECTRICAL OPTIONS (all 60Hz) Special voltages available upon request

Voltage / breaker / running amps / AWG	field retrofittable to	Voltage / breaker / running amps / AWG
<input type="checkbox"/> 208V 3 Ph / 70 / 61.4 / #3	240 V	<input type="checkbox"/> 240V 3 Ph / 80 / 70.8 / #3
<input type="checkbox"/> 480V 3 Ph / 40 / 31.5 / #8	440 V	<input type="checkbox"/> 440V 3 Ph / 35/ 29.0 / #8

ACCESSORIES

<input type="checkbox"/> Installation Kits – include electrical, water and drainage connection	
<input type="checkbox"/> 208 or 240/60/3Ph	8720.1563US
<input type="checkbox"/> 480 or 440/60/3Ph	8720.1552US
<input type="checkbox"/> RATIONAL Cleaner Tabs without phosphorous – guarantee maximum cleaning power	56.00.210A
<input type="checkbox"/> RATIONAL Care Tabs – prevents scale deposits	56.00.562
<input type="checkbox"/> Certified installation by RATIONAL SERVICE-PARTNERS	See document
<input type="checkbox"/> RATIONAL Single Water Filter- for all single models and Combi-Duo XS/XS, 61/61 and 61/101	1900.1154US
<input type="checkbox"/> RATIONAL Double Water Filter- for Combi-Duo 62/62 and 62/102 or if used for more than 2 units	1900.1150US
<input type="checkbox"/> Seven (7) shelf hinging rack	60.62.137
<input type="checkbox"/> Preventative Maintenance Kits – door gaskets, air filters, interior light gasket, and light bulbs	87.00.521US
<input type="checkbox"/> Available stands – standard (stationary) and mobile (open or closed)	See accessories brochure
<input type="checkbox"/> Mobile catering stand – especially for heavy mobile catering usage	60.30.891
<input type="checkbox"/> Catering kit for mobile catering stand – support frame and feet	60.73.141
<input type="checkbox"/> Mobile oven racks and Finishing® plate racks – easier operation of full loads	See accessories brochure
<input type="checkbox"/> Run-in rail for mobile oven and plate racks	60.62.094
<input type="checkbox"/> Transport trolley for mobile oven and plate racks – standard and height adjustable	See accessories brochure
<input type="checkbox"/> Stackable Combi-Duo kit, – for stacking with 61 gas or electric - options: mobile or feet	See accessories brochure
<input type="checkbox"/> Heat shield – for installation next to heat source (e.g. range, grill)	60.70.392
<input type="checkbox"/> Condensation breaker – to divert steam from the unit into existing hood system	60.72.591
<input type="checkbox"/> UltraVent recirculating hood	60.74.972
<input type="checkbox"/> UltraVent Plus recirculating hood	60.74.976
<input type="checkbox"/> RATIONAL USB data-memory stick – for transferring cooking programs and HACCP data	42.00.162
<input type="checkbox"/> VarioSmoker – for a large variety of smoked products	60.73.010
<input type="checkbox"/> For ideal grilling, baking, roasting, frying, rotisserie, steaming, Finishing®, and much more	See accessories brochure

FACTORY INSTALLED OPTIONS (special order)

- Left-hinged door 208V / 240V | 480V / 440V
- Door safety lock – handle is turned left then right before the door can be opened
- Sous-Vide core temperature probe, includes core temperature probe (both attach externally)
- Externally attached standard core temperature probe
- 3 Core temperature probes for iLevelControl includes core temperature probe (both attach externally)
- Lockable control panel cover
- Control panel protection
- Mobile oven rack package (mobile oven rack + run-in rail)
- Unit with special hinging racks for bakeries and supermarkets
- Integrated fat drain (only in conjunction with UG II or US IV stands)
- Marine version (electric units only)
- Security version