

## TYPE A Package Manufacturer's Certification

1. <b>Product Model/Description:</b> 880 OMEGA		
2. <b>Package Specifications/Limitations:</b> Devices are welded, steel, cylindrical construction with a locking assembly attached to one end and a guide tube connection assembly attached to the opposite end. The devices may include an optional jacket assembly for ease of handling, but transport of the devices meets the Type A requirements with or without the optional jacket.		
3. <b>Special Form Source Assemblies Authorized for (All Special Form except Yb-169, which can also ship as Normal Form)</b>		
<b>Type A Approved Activity (Max.)</b>	<b>Isotope</b>	<b>Source Assembly Model Number</b>
15 Ci (0.55 TBq)	Ir-192, Special Form	A424-9, A424-23
80 Ci (2.93 TBq)	Se-75, Special Form	A424-25W, A424-25
30 Ci (1.11 TBq)	Yb-169*, Special or Normal Form	91810, 91808 or 91807
<b>*Note: If shipping as Normal Form maximum activity is 27 Ci.</b>		
4. <b>References:</b> MAN-027, Drawings R880-OMEGA, Test plan Report Nos. 100 & 108 & 109, Test Plan Report 115, Radiation Profile Results Ir-192, Test Plan Report 216 and SAR Oct 2005 for 880 Type B analysis.		
5. <b>Drawing/Assembly Description:</b> Assembly as shown on this certificate.		
6. <b>Maintenance and Operational Controls:</b> MAN-027		
7. <b>Max Weight of Package:</b> 36 lb. (16.3 kg)		
8. <b>Package Closures:</b> The lock assembly must be in the secured position with the selector ring in "LOCK", the dust cover installed and the plunger lock depressed. The front plate port cover must be rotated to the "Shipping" position (see drawings, and a seal wire installed through the front plate port cover to serve as a tamper indicator during shipment.)		

**Under §173.415, QSA Global Inc. certifies that the package and contents described above comply with relevant requirements for a Type A package under the International Atomic Energy Agency Regulations for the Safe Transport of Radioactive Material, 2009 Edition [No. TS-R-1] & 2018 Edition [No. SSR-6], and USDOT Specification 7A under USDOT 49 CFR 178.350.**

**All documentation of tests, engineering evaluation or comparative data demonstrating compliance of this package design to Type A Specification 7A shall be maintained by QSA Global, Inc. and will be available to regulators upon request.**

**The shipper is responsible for ensuring the packaging conforms fully to the requirements identified on this certification including the assembly, maintenance and operational control requirements specified in Sections 5 & 6. Changes to the package assembly, shipment of material not specified on this certificate or any other non-compliance with the requirements of this certificate are not supported under this certification and will invalidate this Type A approval.**

\_\_\_\_\_  
Regulatory Signature

\_\_\_\_\_  
Date

## TYPE A Package Manufacturer's Certification

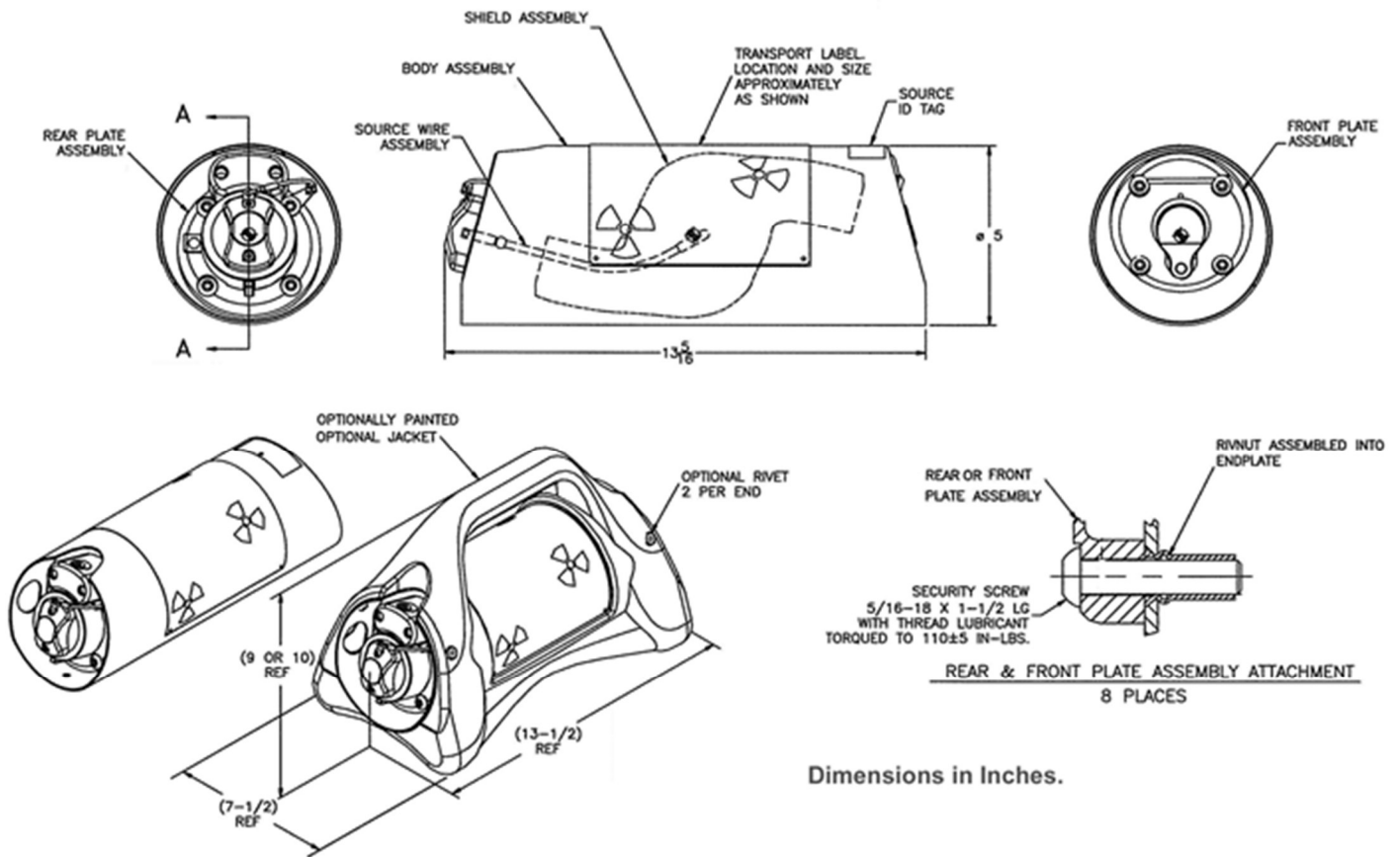

Dimensions in Inches.

TRANSPORT PACKAGE WITHOUT & WITH OPTIONAL JACKET

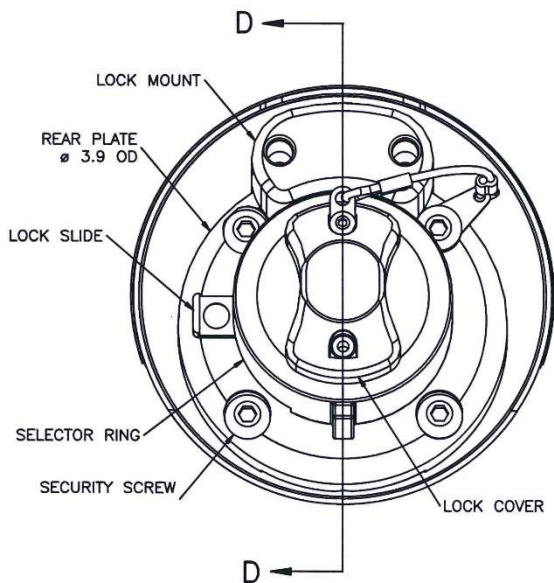

REAR PLATE ASSEMBLY

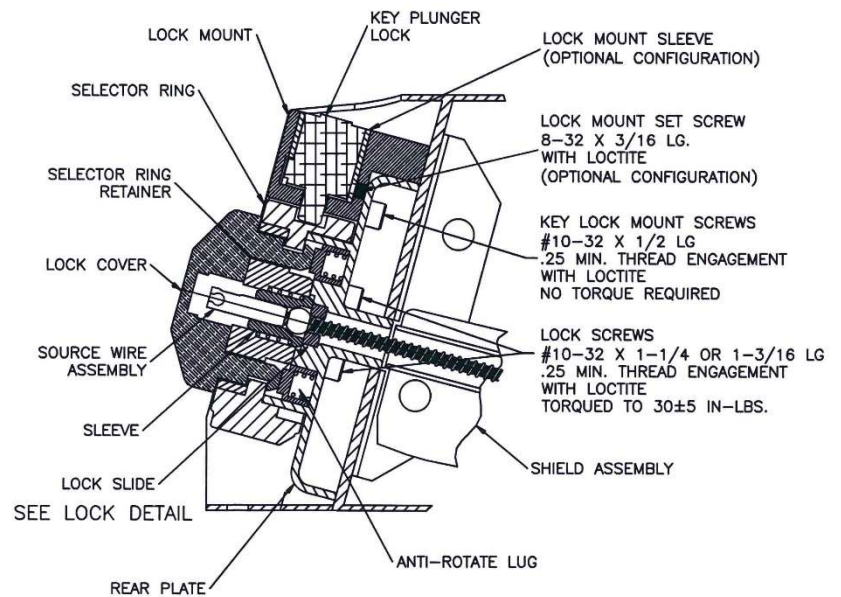

SECTION D-D

DIMENSIONS IN INCHES

## TYPE A Package Manufacturer's Certification

