



ADDENDUM SHEET

For Model 959 MAN-019 (November 2001 Revision)

This following information for the Model 959 radiographic exposure device identifies differences for this device not currently addressed in MAN-019.

In addition to the Model 86550 Control Unit, the Model JB193-000 Control Unit can be used to actuate the source in the Model 959 exposure device. Operation of the JB193-000 Control Unit is similar to the Model 86550 Control Unit. The only significant difference with the JB193-000 unit is that the “Expose” position on the 86550 unit is identified as “VENT” on the Model JB193-000.

References to AEA Technology QSA, Inc. is replaced with QSA Global, Inc. throughout the manual.

Contact QSA Global, Inc. if additional information is required.

This sheet must be included with all copies of the above referenced manual.

SENTINEL

MODEL 959 RADIOGRAPHIC EXPOSURE DEVICE AND TYPE A TRANSPORT PACKAGE

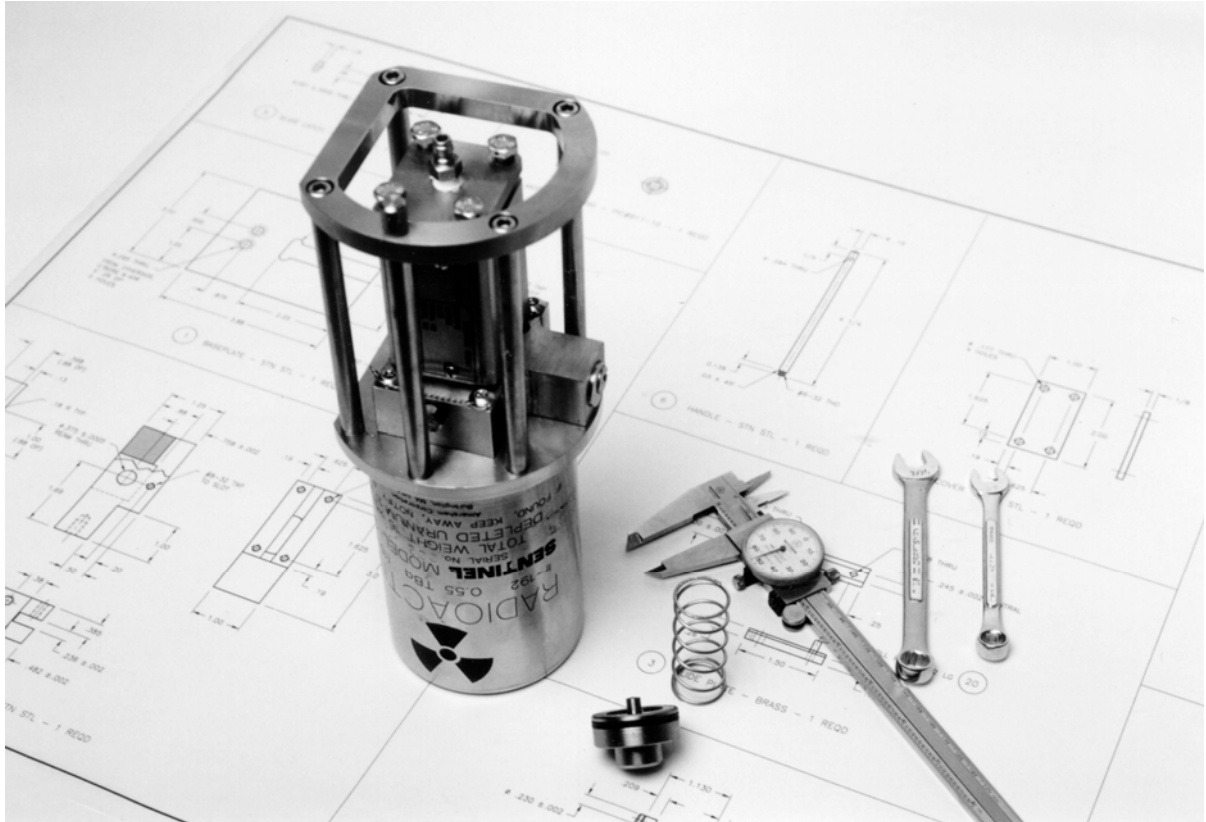

OPERATION AND MAINTENANCE INSTRUCTION MANUAL

TABLE OF CONTENTS

WARNING:	3
NOTICE:	4
SECTION I: GENERAL INFORMATON.....	5
A. General.....	5
B. System Safety.....	5
C. System Components.....	5
1. Model 959 Radiographic Exposure Device.....	5
2. Model 86550 Control Unit.....	5
3. Radioactive Source Assembly.....	6
D. Specifications.....	6
1. Exposure Device.....	6
2. Control Console.....	7
SECTION II: PERSONNEL MONITORING.....	7
SECTION III: ACCESS TO CONTROLLED AREAS.....	7
SECTION IV: TRANSPORTATION AND STORAGE.....	7
A. Receiving Radioactive Material.....	7
B. Shipment of Radioactive Material.....	8
1. Shipment of Radioactive Source.....	8
2. Shipment of an Empty Package.....	9
C. Carrying Radioactive Material.....	9
D. Hand Carrying.....	9
E. Storage.....	9
SECTION V: OPERATION.....	9
A. Principles of Operation.....	9
B. Safety Precautions.....	10
C. Daily Inspection.....	10
D. Assembly.....	11
E. Operation.....	11
F. Disassembly.....	11
G. Emergency Source Retraction.....	12
H. Emergency Response Procedure	12
SECTION VI: SOURCE CHANGING.....	13
SECTION VII: MAINTENANCE.....	13
A. Quarterly Maintenance.....	13
SECTION VIII: LEAK TESTING.....	13

WARNING

Gamma radiography systems emit high levels of radiation during use.

An unshielded source at close range can cause serious *injury, sickness, or death* to anyone who is exposed to it even for a short period of time.

A radiation source must NOT be touched by hand under any circumstances.

Since gamma radiation cannot be detected by the normal human senses, strict procedures must be followed and proper use made of radiation detection instruments to avoid dangerous levels of exposure.

It is very important to prevent access by unauthorized persons to radiographic equipment and to areas where radiography is performed.

The systems must be operated only by properly trained and qualified radiographers, who have read and understand this Operating Manual, or by trained assistants working under their direct supervision.

Take advantage of the three basic radiation protection measures to minimize exposure:

SHIELDING: Use more shielding around the source.

DISTANCE: Increase your distance from the source.

TIME: Spend less time near the source.

MODEL 959

OPERATION AND MAINTENANCE

INSTRUCTION MANUAL

NOTICE

This gamma radiography system is used as a radiographic exposure device and Type A shipping container for AEA Technology QSA, Inc. sources. *The user should become thoroughly familiar with the instruction manual before attempting operation of the equipment.*

Users of this equipment must comply with the regulatory and licensing and transportation rules and regulations as they apply in their respective countries.

This device is intended for use ONLY with AEA Technology QSA, Inc approved system attachments. For information on AEA Technology QSA, Inc approved attachments or additional assistance regarding use of the 959 gamma radiography system, contact AEA Technology QSA, Inc at the addresses shown below:

AEA Technology QSA, Inc
40 North Avenue
Burlington, MA 01803

USA and International: (781) 272-2000

Or

AEA Technology QSA, Inc
6765 Langley Drive
Baton Rouge, LA 70809

USA: (800) 225-1383
International: (225) 751-5893

SECTION I GENERAL INFORMATION

A. General

The Model 959 portable gamma radiographic exposure device is used primarily for the radiography of steel, brass and copper pipes and pipe joints.

The basic radiography system consists of the Model 959 Radiographic Exposure Device and the Model 86550 Control Unit. The exposure device in its transport case serves as the storage and transport package for the radioactive source.

The system may be used with up to 555 GBq (15 curies) of Iridium-192. Sources of lesser activity are available.

B. System Safety

The Model 959 is designed to comply with the following requirements:

- International Atomic Energy Agency Safety Series No. 6 (1985, as amended 1990)
- US Nuclear Regulatory Agency Regulations in 10 CFR 71
- US Department of Transportation Regulations in 49 CFR 173
- Canadian Regulations in:
 - Radiation Protection Regulations
 - General Nuclear Safety and Control Regulations
 - Nuclear Substances and Radiation Devices Regulations
 - Packaging and Transport of Nuclear Substances Regulations
 - Transportation of Dangerous Goods (TDG) Regulations

C. System Components

1. Model 959 Radiographic Exposure Device

The exposure device in its transport case serves as the storage and transport packaging for the radioactive source. The exposure device consists of a stainless steel housing which contains a depleted uranium shield. When the source is in proper shielded storage position in the exposure device, the shielding properties of the depleted uranium reduce radiation intensities in the vicinity of the device to levels well below the regulatory limits.

The radioactive source assembly is attached to the pistons of a pneumatic cylinder. The Model 86550 control unit is used to pressurize the cylinder which causes the source assembly to move from its shielded storage position to the beam port. In this exposing position, the emergent beam is either 30° wide and 30° high or 40° wide and 40° high, dependent on the model used. The radioactive source assembly never leaves the exposure device during normal operation.

The pneumatic actuator is spring loaded in the shielded (OFF) direction. When the air pressure is reduced on the exposing side of the piston, the spring will cause the radioactive source to move to the shielded position. Therefore, in the event of a failure of an air line, the source will automatically be stored in the shielded position.

2. Model 86550 Control Unit

The Model 86550 Control Unit is a pneumatic control designed for use with the Model 959 Exposure Device. The control unit is designed to pressurize the actuating mechanism of the exposure device through the use of a hand pump or through the use of an auxiliary air supply.

The control unit is equipped with a pressure gauge to monitor operating pressure.

The standard control unit is equipped with a 5 meter (16.5 feet) long control hose for attachment to the exposing side of the actuator. Control units with longer hoses are available on an optional basis.

The control unit is equipped with a lock which prevents operation of the unit by unauthorized personnel.

3. Radioactive Source Assembly

The Model 959 Exposure Device is used in conjunction with AEA Technology QSA, Inc. Model 95904 Source Rod Assembly. This source assembly contains AEA Technology QSA, Inc. source capsules which are fabricated from stainless steel or titanium.

Each source capsule is seal welded and meets the requirements of Special Form radioactive material in accordance with IAEA Safety Series No. 6 (1985, as amended 1990).

These sources have been designed and tested to comply with the requirements of International Standard ISO 2919 (1980) and American National Standard N542 (1977). Capsule approval classifications are shown below:

Capsule	Classification
875	C43515
X540	C64334
X540/1	C63344

The Model 959 can contain a maximum of 15 Ci (555 GBq) or Ir-192 or 81 Ci (3 TBq) or Se-75. Sources of lesser activity are available.

The source in the Model 959 may only be changed by a user licensed to do so. Source changing of this device requires the use of a shielded cell and specially designed tools. Because of this, AEA Technology QSA, Inc. recommends that all devices be returned to the manufacturer for source replacement. During this source replacement, the device will be completely inspected and maintained.

D. Specifications

1. Exposure Device

Exposure Device	
Length:	29.2 cm (11 ½ inches)
Diameter:	11.4 cm (4 ½ inches)
Mass:	16 kg (35 pounds)
Shielding Depleted	11 kg (24 pounds)

Uranium:		
Capacity	555 GBq (15 Ci), Ir-192	
Source Assembly:	95904	
Source Capsule:	875 series inner	X540 & X540/1
Special Form Certification:	USA/0392/S-85	USA/0502/S-85

2. Control Console

Control Code	
Length:	273 mm (10.75 inches)
Width:	222 mm (8.75 inches)
Height:	216 mm (8.50 inches)
Mass:	3.9 kg (8.50 pounds)
Control Length to be specified by user.	

**SECTION II
PERSONNEL MONITORING**

Pursuant to Radiation Safety regulations, all personnel who enter a restricted area or are present during radiographic operations are required to wear a direct reading pocket dosimeter with a range of 0 to 2 mSv (0-200 mRem) and either a film badge or thermoluminescent dosimeter (TLD). Additional dosimetry and or alarming rate meters may be required under a specific country's regulations. Check with the applicable Regulatory Authority to ensure all required personnel monitoring is used during radiographic operations.

In the event that a person's pocket dosimeter is found to be off scale, that person must stop all work with radiation immediately. His/her film badge (or TLD) must be sent in immediately for processing, and he/she must not re-enter a restricted area until it has been determined that he/she received less than the maximum allowed occupational exposure as defined in the local regulations.

Radiography personnel should also have a calibrated and operable radiation survey meter capable of measuring from .02 mSv/hr to at least 10 mSv/hr (2 mR/hr to 1 R/hr) to determine radiation levels when performing radiographic operations. (In Canada, the survey meter must be capable of measuring from 0.02 mSv/hr to at least 100 mSv/hr (2 mR/hr to 10 R/hr).

**SECTION III
ACCESS TO CONTROLLED AREAS**

A "Controlled Area" will be required where instantaneous dose rates could exceed 7.5 μ Sv/hr. (0.75 mR/hr). A particular room or building may be designed, or an area marked out. Entry to the "Controlled Area" must be restricted to classified persons, unless under a written scheme of work. The boundary of this area must be suitably labeled. Signs must be used to the standard of the Safety Signs Regulations, 1980, BS3510 and BS5378. Boundary dose rates must be noted and records kept for three years. (In Canada, requirements for controlling access to areas surrounding radiographic exposure operations are described in Part VI, Section 18 of the Atomic Energy Control Regulations.)

SECTION IV TRANSPORTATION AND STORAGE

A. Receiving Radioactive Material

The consignee of a package of radioactive material must make arrangements to receive the package when it is delivered. If the package is to be picked up at the carrier's terminal, this should be done expeditiously upon notification of its arrival.

Upon receipt of the Model 959, inspect the package for signs of external damage and confirm that the tamper-indicating seal has not been broken. If damage is evident, the carrier's agent should be present while unpacking. Survey the package and ensure radiation levels at the surface do not exceed 2 mSv/hr (200 mR/hr) or 100 μ Sv/hr (10 mR/hr) at 1 meter (40 in) from the surface. If the radiation levels exceed either of these two limits, the container should be secured in a Restricted Area and the appropriate personnel notified.

Document radioactive material receipt in accordance with the applicable Regulatory Authority's requirements and/or your radioactive material license.

B. Shipment of Radioactive Material

The Model 959 in the 959A case meets the requirement for a Type A shipping container under the regulations of the U.S. Nuclear Regulatory Commission, the U.S. Department of Transportation and the International Atomic Energy Agency.

1. Shipment of Radioactive Source

1.1 Prior to shipment assure that the package and its contents meet the following requirements:

- a. The contents are authorized for use in the package.
- b. The package is in good physical condition for transport.
- c. All locks are properly engaged and seal wired where required.
- d. All conditions of the Type A documentation are met.

1.2 Assure that the source is locked into place in its proper shielded storage position. To check this, the key operated lock should be engaged and the key removed. Place the 959 securely in the 959A shipping/storage case. Attach a tamper indicator seal with an identification mark to the 959A case.

1.3 If the 959A device is to be packaged in a crate or other outer packaging, the outer packaging must be strong enough to withstand the normal conditions of transport. The device should be put in the outer package with sufficient blocking to prevent shifting during transportation.

1.4 Perform a radioactive contamination wipe test of the outer shipping package. This consists of rubbing filter paper or other absorbent material, using heavy finger pressure, over an area of 300 cm² (46 in²) of the package surface. The

activity should not exceed 0.37 Bq/cm^2 ($0.00001 \mu\text{Ci/cm}^2$) of removable contamination. If the activity exceeds this amount, contact AEA Technology QSA, Inc for guidance on shipment of the package.

- 1.5 Survey the exterior surface of the 959A with a survey meter and assure that the maximum radiation level does not exceed 2 mSv/hr (200 mR/hr) at the surface or $100 \mu\text{Sv/hr}$ (10 mR/hr) at 1 meter (40 inches) from the surface to determine the proper radioactive shipping labels to be applied to the package. If radiation levels above 2 mSv/hr (200 mR/hr) at the surface or $100 \mu\text{Sv/hr}$ (10 mR/hr) at 1 meter (40 inches) from the surface are measured, the container must not be shipped. Contact AEA Technology QSA, Inc for guidance on shipment of the package.
- 1.6 Complete shipment of the container according to proper procedures for transporting radioactive material as established in IAEA regulations and/or other applicable regulations.

2. Shipment of an Empty Package

- 2.1 Perform a radioactive contamination wipe test of the outer shipping package. This consists of rubbing filter paper or other absorbent material, using heavy finger pressure, over an area of 300 cm^2 (46 in^2) of the package surface. The activity should not exceed 0.37 Bq/cm^2 ($0.00001 \mu\text{Ci/cm}^2$) of removable contamination. If the activity exceeds this amount, contact AEA Technology QSA, Inc for guidance on shipment of the package.
- 2.2 Survey the exterior surface of the package with a survey meter and assure that the maximum radiation level does not exceed 2 mSv/hr (200 mR/hr) at the surface or $100 \mu\text{Sv/hr}$ (10 mR/hr) at 1 meter (40 inches) from the surface to determine the proper radioactive shipping labels to be applied to the package as required by IAEA regulations and/or other applicable regulations. If radiation levels above 2 mSv/hr (200 mR/hr) at the surface or $100 \mu\text{Sv/hr}$ (10 mR/hr) at 1 meter (40 inches) from the surface are measured, the container must not be shipped. Contact AEA Technology QSA, Inc for guidance on shipment of the package.
- 2.3 Complete shipment of the container according to proper procedures for transporting radioactive material as established in IAEA regulations and/or other applicable regulations.

C. Carrying Radioactive Material

Any vehicle that is to be used to transport radioactive material should be in good operating condition and carry a normal complement of safety equipment such as Radiation Area signs, rope, spare tire, fire extinguisher, vehicle tools and flares. Before placing the container in the vehicle and securing it against movement, the operator should ensure that the container is properly packaged, marked, and labeled and that the proper shipping papers are completed. The operator should survey the driver's compartment to ensure that radiation levels are below $20 \mu\text{Sv/hr}$ (2 mR/hr).

D. Hand Carrying

In order to minimize radiation exposure, it is recommended that care be taken when hand carrying the unit. A direct reading pocket dosimeter and film badge or TLD should be worn on the side of the body closest to the exposure device. If more than one person is present, it is

good practice to alternate the hand carrying between them to minimize radiation doses to any one individual. Likewise, no person should be permitted to sit on or lounge against the exposure device.

E. Storage

When storing the system, the exposure device must be kept physically secure to prevent tampering or removal by unauthorized personnel. The storage area must be secured such that no unauthorized personnel are allowed entrance. The exposure device must be kept locked and secured during storage.

SECTION V OPERATION

A. Principles of Operation

The source holder assembly, which contains the radioactive source capsule, is positioned such that the source capsule is located in the shielded storage position in the exposure device. This source assembly is attached to the piston in the actuating cylinder. When the cylinder is pressurized, the piston moves the source from its shielded storage position to the beam port. In this exposing position, the emergent beam is either 30° wide and 30° high or 40° wide and 40° high, dependent on the model used. The radioactive source assembly never leaves the exposure device during normal operation.

When the air pressure is reduced on the exposing side of the piston, a spring causes the source assembly to move to the shielded position.

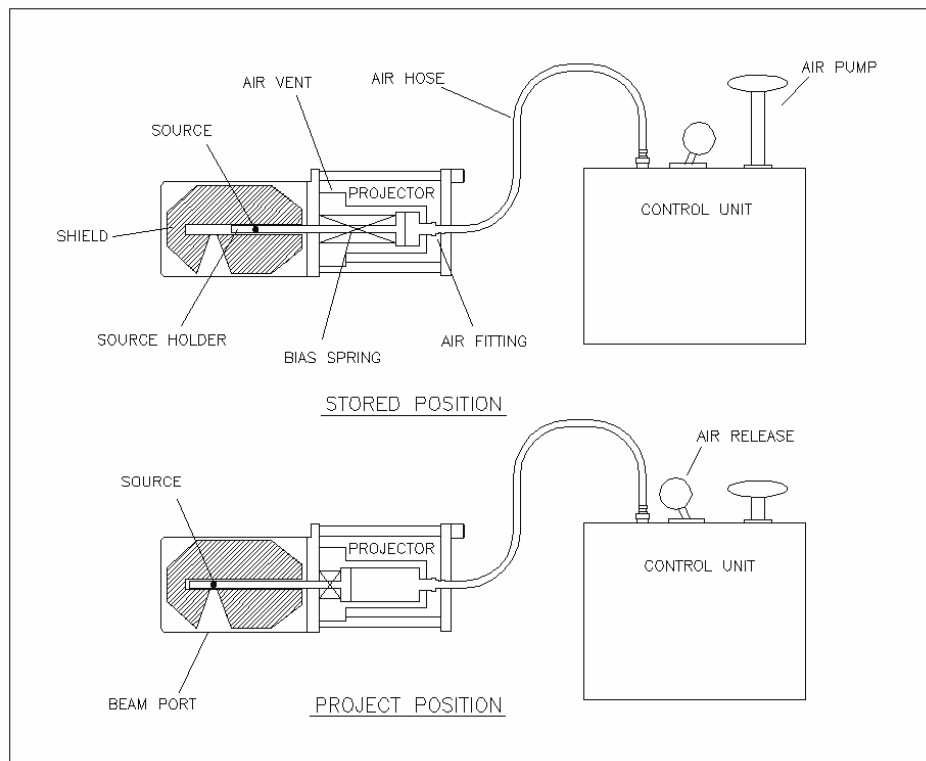

“MODEL 959 – PRINCIPALS OF OPERATION”

B. Safety Precautions

This system may be operated only by personnel properly authorized under a license issued by the Responsible Regulatory Authority. Operating personnel must be physically present and in direct surveillance at all times when the exposure device is being used.

Since the source emits high levels of radiation, it is good practice to operate the system from as great a distance as practicable, and, if possible, from behind a radiation shield such as a heavy steel or concrete object or the corner of a building.

Radiography must only be performed in areas which are properly controlled and marked as specified by the applicable regulatory requirements. While assembling the system it is important to keep the exposure device locked at all times except when operating.

C. Daily Inspection

Daily inspection of the system is required to ensure the equipment is in the proper operating condition. The inspection should be performed prior to the start of each shift.

1. Check the operation of the survey meter and check to assure that the source is properly stored by measuring the radiation intensity at the surface of the device. This radiation level should not exceed 2 mSv/hr (200 mR/hr) if the device is loaded to capacity.
2. Inspect the entire length of the control hose to assure that it is free from cuts, dents and damage.
3. Inspect the end fittings to assure that they are tightly connected.
4. During the first exposure of the shift, check the operation of the source assembly. If operation is difficult or unusual, return the source to the stored position, and survey the equipment according to the Operating Instructions. The system must be serviced before further operation.

D. Assembly

1. Position and secure the exposure device at the radiographic focal position. Note that the radiographic focal position is 51 mm (2 in) from the base of the exposure device.
2. Determine where the control unit will be positioned (as far away from the radiographic focal position as possible and preferably behind a radiation shield) and lay out the control hose from the control unit to the exposure device. Assure that the hose is not kinked.
3. Connect the actuation control hose to the exposure device.

E. Operation

1. Check the position of the exposure device and control hose. Check that all connections are properly made. Assure that the control unit is in the "OFF" position.
2. Assure that no unauthorized personnel are within the restricted area.
3. Unlock the exposure device using the key.

4. At the control unit, with the control switch at the “OFF” position and the “OFF” connection fitted with the sealing cap, pressurize the chamber to approximately 30 psi as indicated on the pressure gauge.
5. Move the control switch to the “EXPOSE” position. The source will move to the exposing position. During the exposure, monitor the radiation intensity using a survey meter. Outside the area of the primary beam, the radiation levels should be less than 20 $\mu\text{Sv/hr}$ (2 mR/hr) at a distance of 3 meters (118 inches) from the exposure device. Monitor the radiation levels at the boundary of the restricted area to assure that it is properly established.
6. At the conclusion of the exposure time, return the source to the shielded storage position by moving the control switch to the “OFF” position. Disconnect the sealing cap to completely empty the chamber as indicated by the pressure gauge.
7. Approach the exposure device with the survey meter and survey the device on all sides. The radiation level should not exceed 2 mSv/hr (200 mR/hr) at the surface of the device. If the radiation levels exceed these limits, treat the situation as an emergency and notify your supervisor or Radiation Safety Officer.
8. When the source is properly stored in the shielded position, lock the exposure device by depressing the lock plunger.

F. Disassembly

1. Assure that the exposure device is locked. Remove the key.
2. Disconnect the control hose from the exposure device.
3. Survey the external surfaces of the device to assure that the radiation levels do not exceed 2 mSv/hr (200 mR/hr). Survey at one meter from the external surfaces of the device to assure that the radiation levels do not exceed 100 $\mu\text{Sv/hr}$ (10 mR/hr).

G. Emergency Source Retraction

If radiation levels exceed 2 mSv/hr (200 mR/hr) at the surface of the device or the lock plunger cannot be depressed when the source should be in its stored position, notify your supervisor or Radiation Safety Officer. The following procedure defines the steps that may be taken to manually return the source to its stored position:

1. Approach the exposure device from the side opposite the beam port with a survey meter.
2. Unscrew the knurled knob from the handle ring of the exposure device and remove the source retraction tool (the knurled knob is an integral part of the tool).
3. Remove the actuation control hose from the exposure device.
4. Insert the small end of the source retraction tool through the air fitting on the exposure device and screw it clockwise into the source rod.
5. Pull the tool to pull the source to its stored position and lock the exposure device by depressing lock plunger.
6. Unscrew the source retraction tool and screw it back into its storage tube.

7. Return the device to AEA Technology QSA, Inc. for a complete inspection.

H. Emergency Response Procedure

These immediate actions should be taken to protect personnel by establishing and maintaining a restricted area around the radiation device allowing time to perform Emergency Response Actions in a controlled manner.

Any of the following conditions warrant implementation of the Emergency Response Procedures:

- Inability to return the source to the fully shielded position within the device as described under sections G. of this manual.
- Damage to the device shielding creating elevated dose rates around the device.
- A failure of any component that's critical to the safe operation of the device.

During performance of Emergency Response Actions, the Radiation Safety Officer or their alternate must maintain control of the affected area.

Actions to be Performed

1. **Stop and Think:** Recognize an emergency situation exists. Attempt to reduce external dose rates by adding supplemental shielding (e.g., lead, concrete block, steel, etc) around the elevated dose rate areas of the device.
2. **Re-Establish the Restricted Area Boundaries:** Survey the area and re-establish, or adjust as necessary, the restricted area boundaries. Maintain control of radiation areas to ensure no unauthorized access to the device or affected areas.
3. **Notify AEA Technology QSA, Inc and the Responsible Regulatory Authority:** Advise of the situation, giving as much detail as possible and obtain advice on further actions to take to return conditions to normal. Information should include identification of the equipment involved, the cause of the incident, actions taken to establish a safe condition, doses to all personnel involved and corrective actions taken to prevent recurrence (if known at the time).

SECTION VI SOURCE CHANGING

The source in the Model 959 may only be changed by a user licensed to do so. Source changing of this device requires the use of a shielded cell and specially designed tools.

Therefore, we recommend that all devices be returned to AEA Technology, QSA, Inc. for source replacement. During this source replacement, the device will be completely inspected and maintained.

SECTION VII MAINTENANCE

A. Quarterly Maintenance

1. Clean and inspect the device for obvious damage. Report any defect that may impair its safe operation and withdraw it from service until repairs can be made.
2. Check that the radioactive warning information engraved on the outer shell is legible. Do not cover with any other labels.
3. Check that the air supply inlet is not damaged.
4. Inspect the air supply hose for cuts or damage to the end fittings.
5. Check the model 86550 control unit for proper operation. With the operating switch in the "OFF" position, pressurize the unit to 30 psi. Check the gauge reading for evidence of a leak in the system. If pressure does not hold, the control unit must be repaired or replaced.

NOTE: When the 959 device is returned to the manufacturer for source reloading it will be completely inspected and maintained. This should be done at least annually if used under normal operating conditions.

SECTION VIII LEAK TESTING

The source assembly used in the Model 959 should be leak tested for removable radioactive contamination at intervals not to exceed six months. This can be accomplished using AEA Technology QSA, Inc. Model 518 Leak Test Kit or equivalent test kit.

This test must be performed in a properly secured Controlled Area. The individual performing this test should wear a direct reading pocket dosimeter and either a film badge or thermoluminescent dosimeter. The individual should also use a properly calibrated and operable radiation survey instrument.

1. Assure that the exposure device is locked. Assure that the source assembly is in the proper shielded storage position by surveying the exposure device at the surface and at 1 meter (40 inches) from the surface. The radiation levels should not exceed 2 mSv/hr (200 mR/hr) at the surface nor 100 μ Sv/hr (10 mR/hr) at 1 meter (40 inches) from the surface when the device is loaded to its capacity.
2. Moisten the wipe test swab with EDTA solution. Wipe the area around the lock. Wipe the air inlet on the actuator assembly. Wipe the end fittings of the control hose.
3. Place the wipe test swab in the plastic envelope.
4. Set the survey meter on its most sensitive range and determine the background radiation in a low background area. Move the wipe test swab towards the meter and observe the radiation level indication.

5. If there was no measurable increase above the background radiation level, place the plastic envelope in the mailing box and send to AEA Technology QSA, Inc. (In Canada, arrange for the wipe to be sent to AEA Technology QSA, Inc. by courier) Be sure to complete and return the identification sheet.

6. If the meter indicates an increase above the background radiation level, **DO NOT MAIL OR SEND THE WIPE TEST PATCH.** Contact AEA Technology QSA, Inc. for further instructions.

AEA Technology QSA, Inc. and SENTINEL are trademarks of AEA Technology QSA, Inc.

All goods and services are sold subject to the terms and conditions of sale of the company within the AEA Technology QSA, Inc. which supplies them. A copy of these terms and conditions is available on request.

©AEA Technology QSA, Inc – All rights reserved

AEA Technology QSA, Inc.
40 North Avenue
Burlington, Massachusetts 01803
Telephone #: (800) 815-1383 (781) 272-2000