

SENTINEL™

OpenVision™

OVCF-NDT-70

OpenVision™
LIVE VIDEO X-RAY

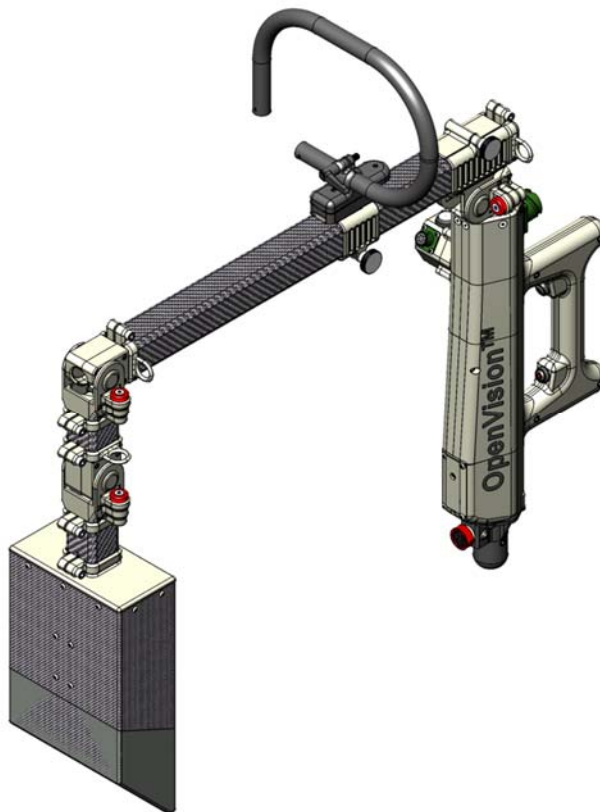

Operation Manual

MAN-050-v2.8-Feb 2017



QSA GLOBAL



WARNING - IMPORTANT SAFTY INFORMATION

- Only trained and qualified personnel who have read and fully understand this operating manual are authorized to use this system.
- Using this system without the proper training and/or failing to adhere to the related safety procedures can result in life-threatening dangers.
- During use, this system will emit high levels of penetrating X-ray radiation that cannot be detected by the human senses.
- High radiation exposure at close range can cause injury, sickness or death to anyone who is exposed to it even for a short period of time.
- Always use a calibrated survey meter when using this system to avoid potentially dangerous levels of radiation exposure.
- Wear and use proper dosimetry including film badges or thermoluminescent dosimeters, direct reading pocket dosimeters, and audible alarm ratemeters while using this system and during all radiographic operations.
- Take advantage of the three basic radiation protection methods to minimize radiation exposure:
 - TIME: Spend less time near the radiation source.
 - DISTANCE: Increase your distance in a direction away from the radiation source.
 - SHIELDING: Whenever possible, always apply the use of effective shielding between you and the radiation source



Warranty and Limitation of Liability

QSA Global, Inc. (herein referred to as the manufacturer) warrants its product which it manufactures and sells to be free from defects in material and workmanship for a period of one year from the date of shipment. This warranty shall not apply to any product or parts which have been subjected to misuse, improper installation, repair, alteration, neglect, accident, abnormal conditions of operation, or use in any manner contrary to instructions.

The manufacturer's liability under such warranty shall be limited to replacing or repairing, at its option, any parts found to be defective in such respects, which are returned to the manufacturer, transportation prepaid; or at its option, to returning the purchase price thereof.

The warranty on other manufacturer's components shall be that of the original manufacturer whose warranty shall be binding.

In no event shall the manufacturer be liable for any incidental or consequential damages, whether or not such damages are alleged to have resulted from the use of such product in accordance with instructions given by or referred to by the manufacturer.

QSA Global, Inc. assumes no liability or responsibility for the usage of this device for the generation of penetrating radiation. The use of such generators in any manner other than prescribed in a State registration or permitted by any State x-ray regulations may constitute a violation of such license or regulatory terms.

All other warranties, except those warranties expressly stated herein, including without limitation warranties of merchantability and implied warranties of fitness, are expressly excluded.

The warranty on this device is specifically limited to its use only with parts, and accessories manufactured by QSA Global, Inc.

Sentinel™, OpenVision™, QSA Global, Inc. shall not be liable for any errors or omissions contained herein and the provision by Sentinel™, OpenVision™, QSA Global, Inc. of the information set out in this manual does not in itself constitute acceptance of any liability on the part of Sentinel™, OpenVision™, QSA Global, Inc.

Copyright ©2017 by QSA Global, Inc. All rights reserved.

No part of this document may be reproduced, stored in a retrieval system, or transmitted in any form or by any means, electronic, mechanical, photocopying, recording, or otherwise, without the prior written consent of the publisher.

Contents

Introduction	5
Equipment Specifications.....	5
Operation	6
Operating Conditions	8
X-Ray Training	9
Precautions	9
Getting to know OpenVision™	10
System Overview	10
NDT X-Ray Tube Housing	10
Accessory Hub.....	11
Connections	12
Controller	13
LCD Monitor	14
DVR.....	15
Heads-Up Display Glasses	17
Wireless Transmitter.....	18
Color Changing Dialight.....	19
X-Ray Trigger(s)	20
Integrated	20
Remote.....	21
Operation	21
Safety Interlocks.....	21
Setup	22
Safety	24
Radiation Zones.....	24
Warm up procedure.....	25
Audio Warning Beeps.....	26
Scanning.....	26
Shutdown	27
C-Arm Extension.....	27
Transmitter	28
Heads Up Display	28
Maintenance	30
Troubleshooting.....	31
Appendix 1: Parts List.....	33



Introduction

OpenVision™ live video x-ray system enables real-time, qualitative screening for corrosion under insulation (CUI). CUI causes can create major cost and safety issues if not identified and corrected. The OpenVision™ screening system will identify problem areas quickly, saving valuable time and resources.

OpenVision™ effectively increases inspection productivity in the refinery, pipeline, and offshore environments. The lightweight, ergonomic c-arm frame significantly reduces fatigue during the inspection. In addition, robust eyelet attachment points enable operators to safely perform rope access inspection. Versatility and reliability make OpenVision™ an efficient addition to an NDT inspection toolbox.

Equipment Specifications

Imaging Area (Field of View)	4 in. x 6 in. (10 cm x 15 cm)		
Dimensions X-ray tube to Imager	Standard – 19 in. (48 cm) Extension – 25 in. (63.5 cm)		
Throat depth	20 in. (51 cm)		
Image Acquisition Time:	30 FPS – Real-time NTSC Video		
X-Ray Energies	kVp (Voltage)	μA (Current)	R/hr output (12 in. from the port)
Low	40	100	6
Medium	55	200	20
High	70	300	60
Approximate Beam Collimation	18° Horizontal 12° Vertical		
Spatial Resolution	250 Micron /0.010 in. (0.0254 cm)		
Weight C-Arm Controller (w/ battery)	13.8 lbs. (6.3 kg) 3.2 lbs. (1.5 kg)		
Packaged system (shipping weight)	53 lbs. (24 kg.)		
Operating Temperature	-20° F to 120° F (-29° C to 49° C)		
Storage Temperature	-30° F to 140° F (-34.5° C to 60° C)		
Display	7 in. LCD Monitor 5 in. DVR (optional) HMD (optional)		
Recording	DVR with 4GB SD card (standard) and expandable up to 32GB		
Shipping Dimensions	32 in. x 20.5 in. x 12.5 in (82 cm x 52 cm x 32 cm)		

	EN 55011:2009 + A1:2010 / CISPR 11:209 + A1:2010 Radiated Electromagnetic Emissions IEC 61000-4-2 Electostatic Discharge Immunity IEC 61000-4-3 Radiated Electric Field Immunity IEC 61000-4-8 Power Frequency Magnetic Field Immunity
FDA Accession #	1680071-000

Operation

Personnel operating this equipment must be completely familiar with this manual and they must read and understand these important safety alerts before proceeding.

IMPORTANT SAFETY ALERTS
NOTICE: Can cause minor problems and reminders.
CAUTION: Can cause equipment damage or potential problems.
WARNING: Can cause serious or fatal injury.
DANGER: Will cause serious or fatal injury.





WARNING

- ✓ Do not perform any unauthorized modifications to the OpenVision™ system or components of the system.
- ✓ It is important that trained and qualified personnel perform or supervise a daily safety inspection of the OpenVision™ system for obvious defects before using the system. Do not compromise on safety. Always perform the daily inspection of the system prior to use.
- ✓ Any foreign material (dirt, mud, ice, etc.) must be removed before using the system. Inspect, clean, and test the equipment as described in this manual to ensure long-term safety and reliability.
- ✓ Do not use any component that is not approved for use with the OpenVision™ system or any after-market component as they may compromise the safety features designed into the system.
- ✓ Defective equipment that is discovered during the daily inspection must be removed from service until repaired or replaced.
- ✓ The user of this equipment must follow the operating instructions, in the order shown, to ensure safe operations and compliance with government regulations.





WARNING: JOB SITE SAFETY PRECAUTIONS

Personal Safety Instruments

The qualified operator and assistants must at all times wear a film badge or TLD and pocket dosimeter with a range of 0-2mSv (0-200mRem). Regulatory requirements in the USA also require that an audible alarm ratemeter is worn at temporary job sites. Temporary job sites are, specifically, those locations that are not permanent radiographic installations equipped with functional door interlocks and audible/visual alarms.

Qualified operators in the USA must also have a survey meter capable of measuring in the range of 20 μ Sv/hr (2mR/hr) up to 10mSv/hr (1,000mR/hr).

Canadian regulations require that survey meters used be capable of measuring from 2 μ Sv/hr (0.2mR/hr) and up to 100mSv/hr (10R/hr).

In any regulatory jurisdiction, always verify survey meter requirements affecting the range and calibration requirements prior to engaging in industrial radiography operations.

An audible 'chirper' pocket alarm may be required in some countries.

It is the responsibility of users of this equipment outside of the United States to comply with all local, national and international licensing rules and regulations as they apply in their respective countries.

Surveillance

Only trained and qualified individuals or assistants working under their direct supervision may operate the OpenVision™ system. The qualified individuals must be physically present at the site and able to control and limit access to the vicinity of the work.

Locking

Keep the OpenVision™ controller locked while assembling the system and when not being used to perform scanning. Locked is defined as the controller key switch in the Off position with the key removed. Store the key in a secured location.

OpenVision™ utilizes a proprietary intensified video imaging system that captures radiographic images that are then displayed on a hand-held LCD, head mounted display or portable recorder with LDC display in real-time (30 frames/sec).

Operating Conditions

OpenVision™ is designed for applications where the equipment and cabling will not be exposed to harsh handling or environmental extremes. See Equipment Specifications for more information



X-Ray Training

It is required that operators of OpenVision™ are properly trained and qualified to perform radiographic inspections. This manual does not address radiographic inspection techniques or procedures.

Precautions

OpenVision™ is designed for portability but contains components that are delicate and fragile. Use care and avoid strong vibrations and shock conditions (i.e. equipment drops or transportation outside the approved case) to the x-ray housing, imager and displays.

CAUTION

Do not attempt to open or modify the imager, x-ray tube or controller housing. Opening any of the previously listed components will void the system warranty and may expose you to a high voltage shock hazard.

CAUTION

Do not allow liquids to come into contact with any part of the OpenVision™. Appropriate care should be taken to protect all cabling and connectors to ensure the reliable and safe operation of the OpenVision™



Getting to know OpenVision™

System Overview

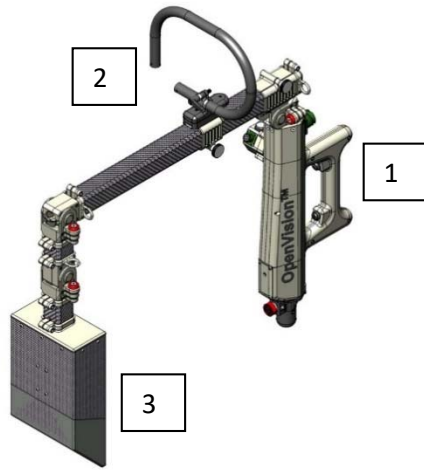

1	NDT X-Ray Tube Housing
2	Top Handle (attached to movable Picatinny rail slider)
3	Imager

NDT X-Ray Tube Housing

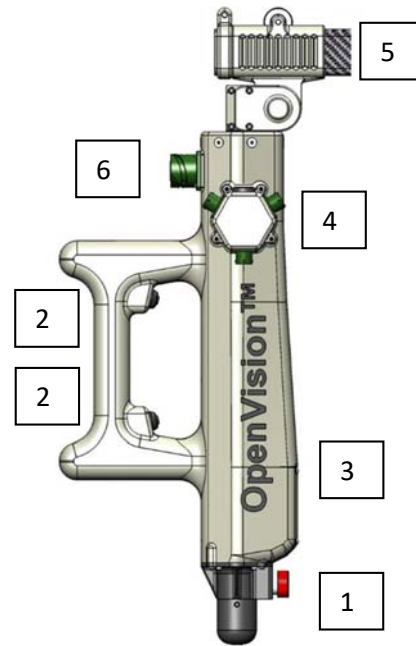

1	X-Ray Port
2	NDT Integrated X-Ray Triggers
3	Targeting Camera and Laser
4	Accessory Hub (X-Ray light status located on top; See Section 2.2.2)
5	Carbon Fiber Slider
6	Controller Cable Connector

Accessory Hub



1	C-Arm Connector
2	Color Changing Light
3	6-Pin Accessory Connection
4	6-Pin Accessory Connection

Connections

Line up notches on both connector and port



Push in and turn clockwise until click.

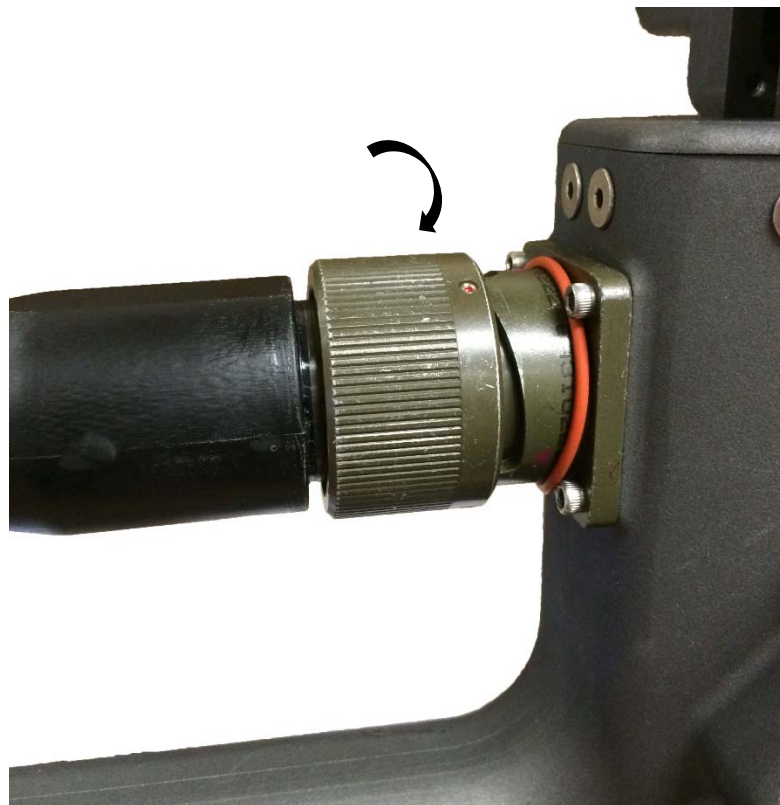

Controller

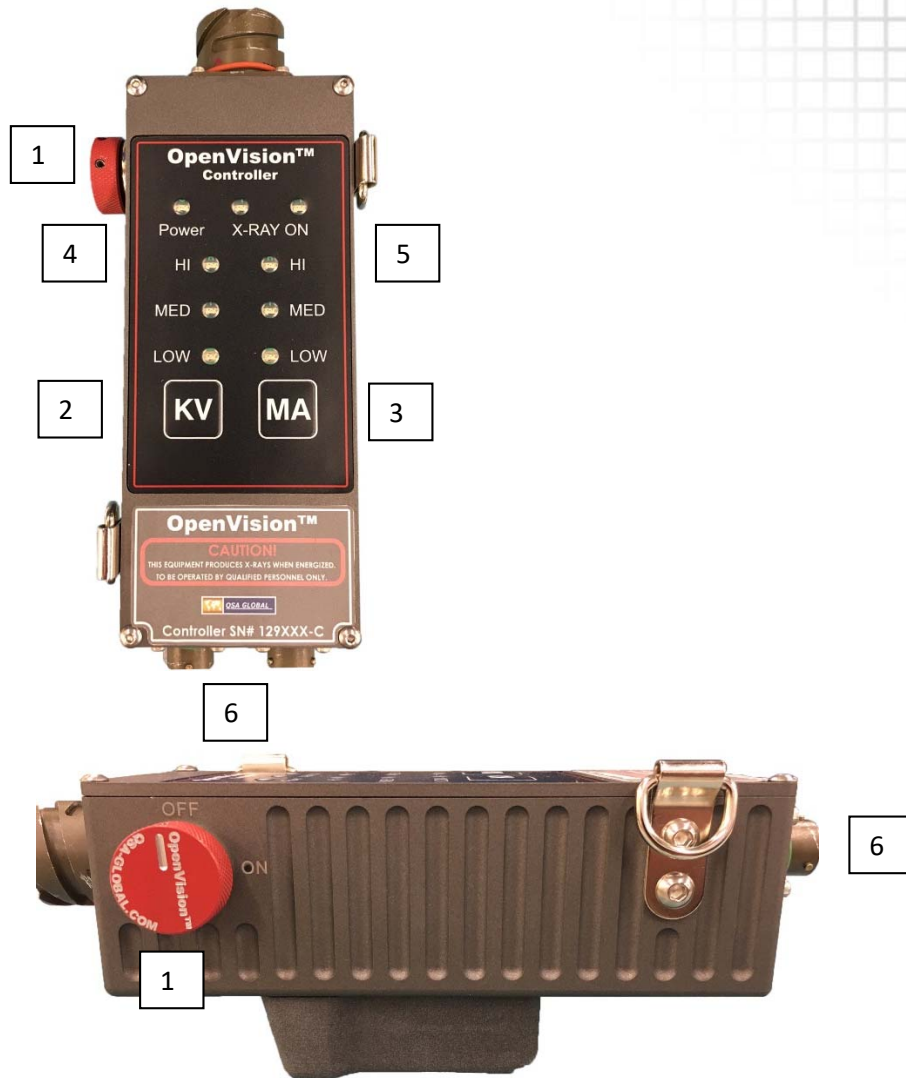

1	Key Switch
2	Voltage Adjustment: Low – 40 kV / Med – 55 kV / Hi – 70 kV
3	Current Adjustment: Low – 100 μ A / Med – 200 μ A / Hi – 300 μ A
4	Power On Light
5	X-Ray On Lights
6	Monitor and Trigger Accessory Connections



WARNING

When the X-Ray On lights are on (amber), ionizing radiation is being produced.



LCD Monitor



To use menu: Press menu; use right, left, up, and down arrows to navigate

1	Power On/Off
2	Input (Select AV1)
3	Brightness (v ^)
4	Menu
5	Volume (< >)



DVR



1	DVR
2	Power Cord
3	SD Card and Adapter
4	6-Pin Connector (not needed when using the wireless transmitter)
5	Audio Video Cables
6	USB Cable

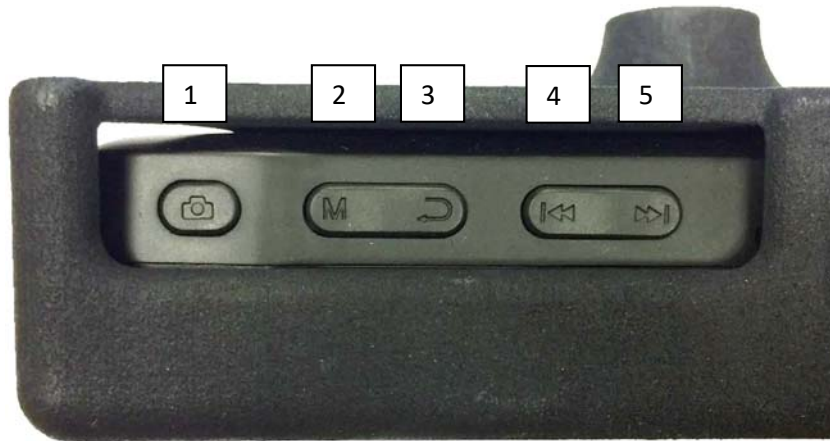

1	(Press) Screen Capture; (Hold) Start Record
2	Power Button
3	ESC Button/Return to Previous Menu
4	Previous Switch
5	Next Switch

DVR (cont.)

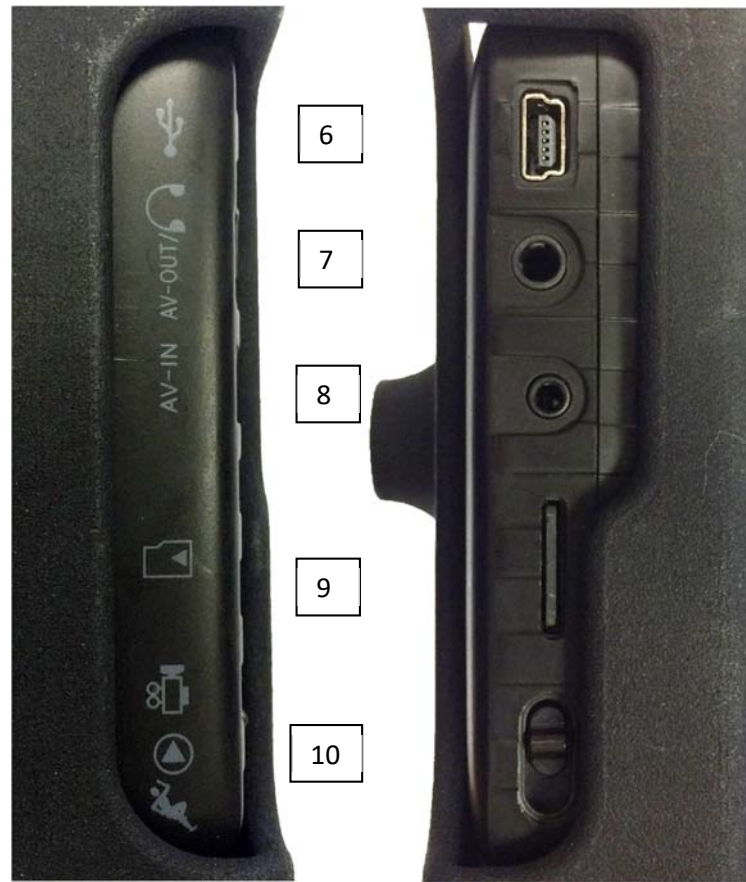

6	USB/Charger Input
7	AV Out
8	AV In
9	Micro SD Slot (Max 32 GB)
10	Record Mode/Playback Mode/Motion Detect (not used)

Heads-Up Display Glasses

Ballistic Protection Standards:

- U.S. MIL SPEC MIL-PRF-31013
- ANSI Z87.1+
- U.S. Federal OSHA
- CE EN 166 FTKN

Temperature:

- Storage: -4°F to 140°F (-20C – 60C)
- Operating: 32°F to 122°F (0C-50C)

Weight

- 114 g



Wireless Transmitter

CAUTION

Do not operate unit without antenna; doing so can damage the transmitter

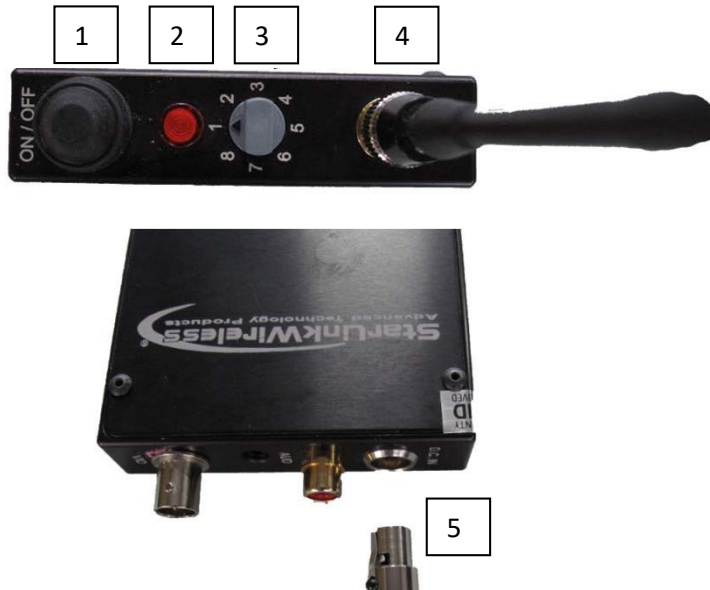

1	Power Button
2	Power Light
3	Channel Selector
4	Antenna
5	6-Pin Cable Connector



Color Changing Dialight

Located on top of the accessory hub



The color changing light indicates the readiness of the device. It is an integrated safety feature on OpenVision. Blue indicates the system is ready. When the trigger is pressed and x-rays are being emitted, the light will turn to red.

1	Blue – System ready
2	Red – X-rays ON



WARNING

When the color changing light is red, ionizing radiation is being produced.



X-Ray Trigger(s)
Integrated

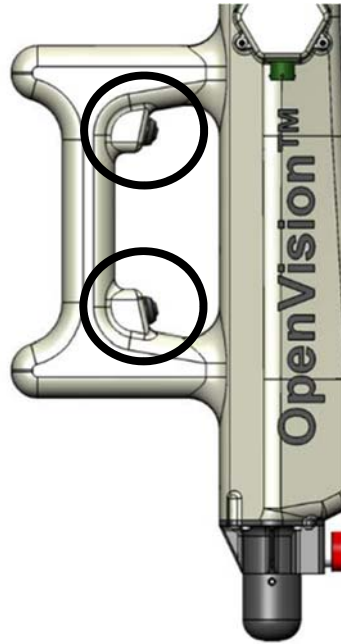

Press and hold either trigger button to begin producing x-rays.

Remote

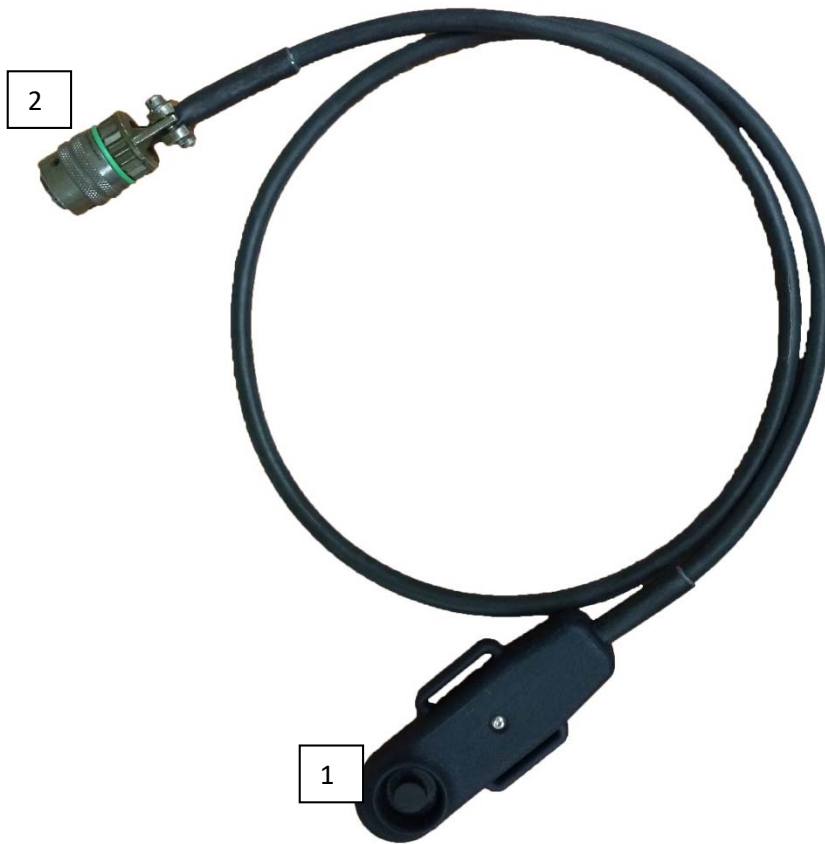

Attach remote trigger to accessory hub or controller accessory 6-pin connectors to use the remote trigger to produce x-rays.

1	Trigger Button
2	6-Pin Connector

Operation

Safety Interlocks

If either of the indicator X-Ray On LED's on the controller does not work, the unit cannot be energized consistent with ANSI/HPS 43.5 Section 5.1.1

A "deadman" switch (90 Seconds) for the "x-ray on" control disables the generation of x-rays after 90 seconds of continuous x-ray on condition, consistent with ANSI/HPS 43.5 Section 4.5.2

Unplugging/plugging in the battery or other ground fault condition will not cause the X-ray tube unit to be energized consistent with ANSI/HPS 43.5 Section 11.1

Setup

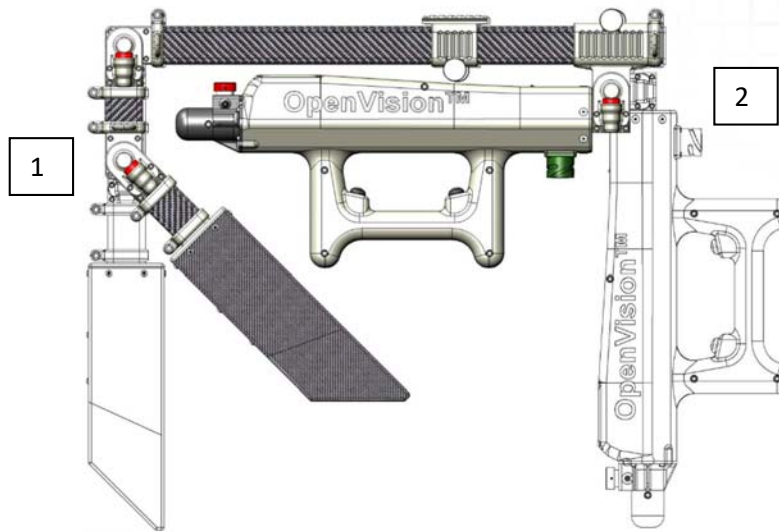

Step 1 – Press the red button down on the imager joint to release and straighten the imager

Step 2 – Press the red button down on the x-ray tube housing joint to release and lower the x-ray tube housing

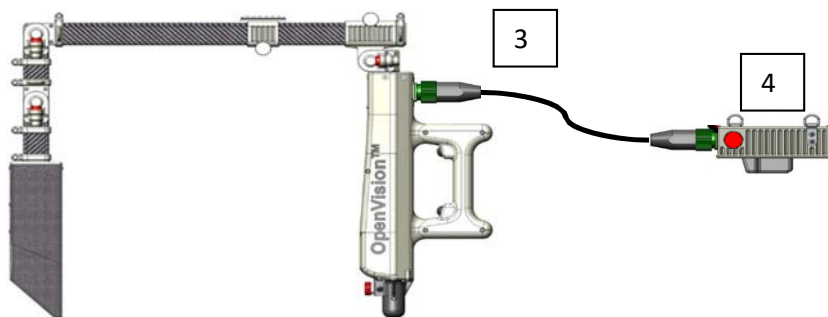

Step 3 – Connect the Controller Cable to the male connector on the x-ray tube housing

Step 4 – Connect the Controller Cable to the male connector on the controller

Step 5 – Connect the LCD, DVR, or HMD to one of the Green Label accessory connectors on the X-Ray Tube Housing or Controller.

Step 6- Connect the Top Handle to the Picatinny Rail

Step 6a: Loosen screw



Step 6B: Push onto Picatinny rail

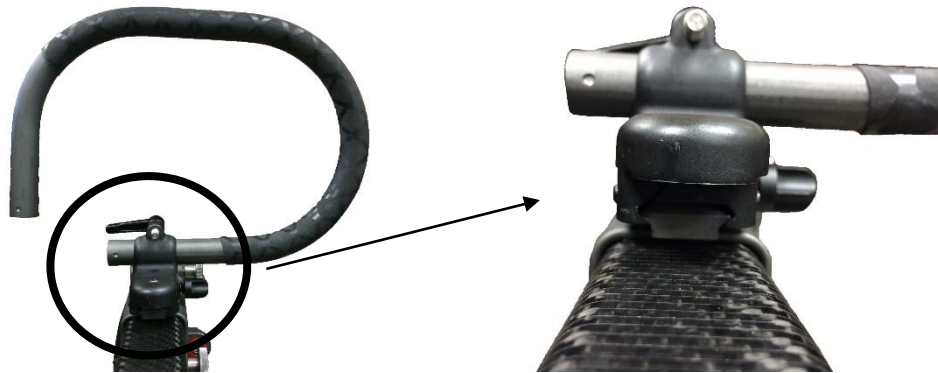

Step 6C: Tighten screw to secure handle

Step 7 – Connect the Milwaukee M18 battery to the controller

Step 8 – Initiate the warm up procedure

Safety

Radiation Zones

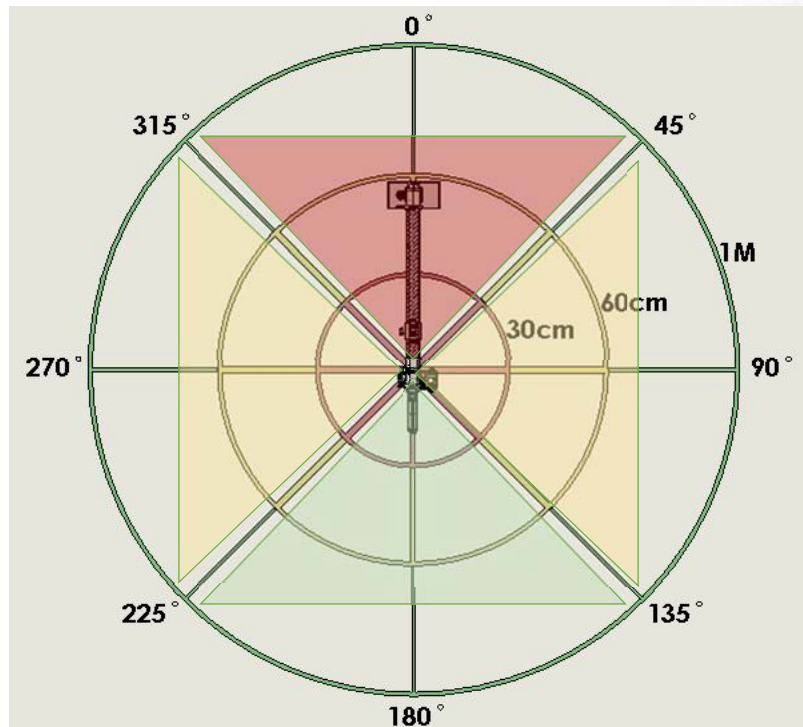

During normal operation, e.g. scanning a pipe for corrosion under insulation, the area behind the 'D' handle trigger has the lowest dose rates during exposure. The major dose contribution to the surrounding areas at the 225 and 135 position is scatter off of the object being scanned, not the direct beam readings.

The High kV / Low mA is the most common usage setting of the device as the x-ray penetration results in sufficient image visual clarity during the performance of a scan. The High/High settings should only be used for rare cases where additional X-ray power is required to see through difficult material.

When estimating whole body dose levels for a job, the user should also factor in realistic estimates of actual run time. A 50% on/off duty cycle is recommended to protect the X-ray tube. Because of the variance in pipe size/materials the level of dose scatter can vary. Personnel dosimetry is required.

Example of dose rates for corrosion under insulation

(results may vary depending on material scanned)

Application: Insulated Water 6" Pipe			
kV Setting: High (70 kVp)			
mA Setting: Low (100 μ A)			
Plane: Centerline X-Ray Tube Port			
Dose Rate Readings: mR/hr			
<i>Position</i>	<i>30cm</i>	<i>60cm</i>	<i>1m</i>
0	-	-	0.04
45	-	1.4	0.1
90	5.1	0.9	0.3
135	4.1	1.1	1.7
180	0.6	0.1	0.09
225	3.2	0.9	0.4
270	4.6	0.8	0.2
315	-	1.2	1.2

Application: Insulated Water 6" Pipe			
kV Setting: High (70 kVp)			
mA Setting: High (300 μ A)			
Plane: Centerline X-Ray Tube Port			
Dose Rate Readings: mR/hr			
<i>Position</i>	<i>30cm</i>	<i>60cm</i>	<i>1m</i>
0	-	-	0.6
45	-	4.4	0.8
90	15.4	2.9	1.1
135	13.4	3.8	1.3
180	2.2	0.7	0.3
225	11.2	3.9	1.6
270	14.4	2.7	0.8
315	-	4.2	4.1

Warm up procedure



WARNING

When the unit is warming up it is emitting X-rays only when the trigger is held. Ensure proper precautions are being taken prior to energizing the unit.

- Step 1 Place the unit in an area where it is approved to emit X-rays
- Step 2 Place the key switch to the 'On' position
- Step 3 Select the preferred kV/mA position
- Step 4 Hold the trigger until the long beeps are heard from the controller

KV Controller Setting	mA Controller Setting	Duration
High	High	65 Seconds
Medium	Medium	55 Seconds
Low	Low	35 Seconds



Audio Warning Beeps

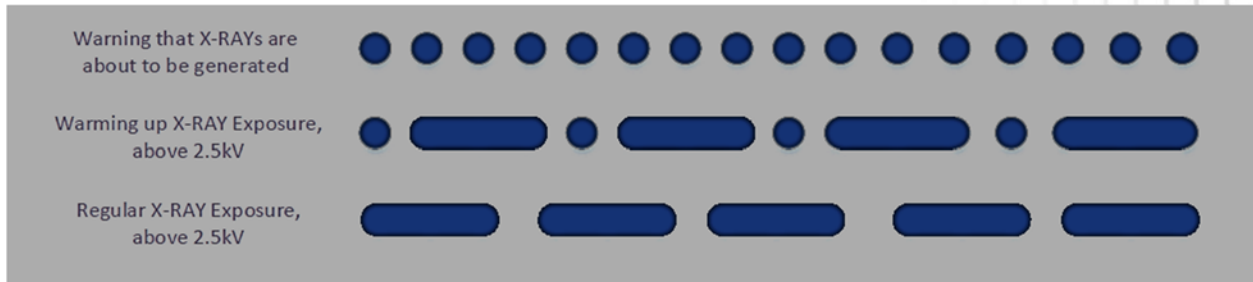

Short beeps are the pre-warning that X-RAYS are about to be generated (10 Seconds)

Short long short long indicates that the X-RAY tube is warming up and above 2.5kV

Long beeps indicate that a regular X-RAY exposure is occurring.

Short continuous beeps may occur at any time if the battery voltage is too low.

Scanning

The Openvision™ is designed to utilize two hands on the device, one at the trigger 'D' handle and one on the top rail handle, as illustrated:

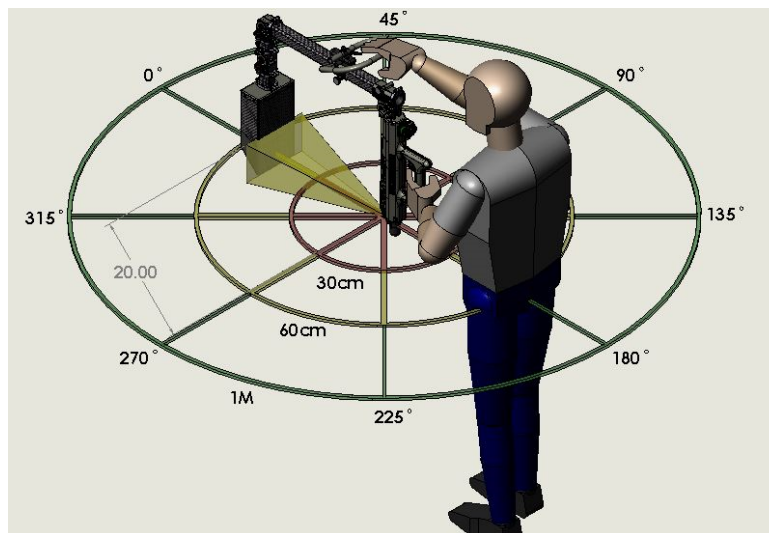

Simply Depress the trigger and begin scanning with the X-ray tube as close to the pipe as possible to minimize scatter. Scanning rates will vary based upon the material being scanned and the environmental conditions, but nominally can be performed at a 4-6" per second rate, pausing between scans to prolong the x-ray tube life. The unit is programmed to shut off after a 90-second exposure. It is recommended that a second person is behind the operator, providing guidance for the operator while scanning, carrying accessories and to act as a safety spotter.

Shutdown

There is no ramp down of the system required. System shut down is simply turn the key switch to the OFF position, disconnect the battery and place the unit in storage.

C-Arm Extension

Included with OpenVision™ is a carbon fiber extension tube for the C-Arm. This will allow the distance between the Imager and X-Ray Tube Housing to be increased to 25in. (63.5cm).

To set up OpenVision™ with the C-Arm Extension, perform the following steps:

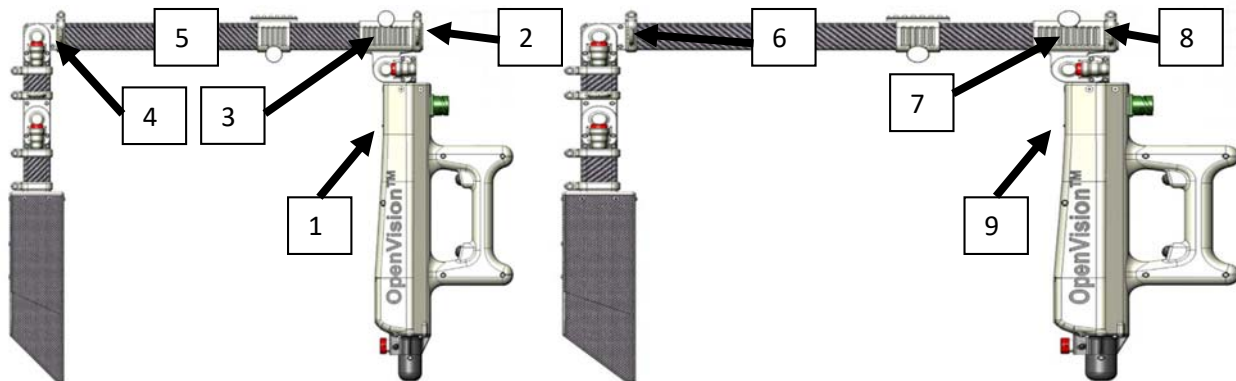

Step 1 – Disconnect the imager cable from the accessory hub (hub not shown in image).

Step 2- Loosen and remove the clamp on the X-Ray Tube Housing side

Step 3 – Loosen the slider on the X-Ray Tube Housing and slide the Housing off the carbon fiber arm

Step 4 – Loosen the clamp on the Imager side

Step 5 – Remove the carbon fiber arm

CAUTION

There is an Internal Cable inside the carbon fiber arm, it is attached to the imager and care should be used not to stretch the cable excessively while removing the carbon fiber arm

Step 6 – Insert the C-Arm Extension into the Imager side and secure the clamp

Step 7 – Slide on the X-Ray Tube Housing and secure the slider

Step 8 – Secure the clamp on the X-Ray Tube Housing side

Step 9 – Reconnect the imager cable on the accessory hub (the six pin connector with the orange band).

Transmitter

CAUTION

Do not operate unit without antenna; doing so can damage the transmitter

Step 1 - Connect green-label end of 6-pin connector into the green-label connector on the controller

Step 2 – Connect the antenna to the transmitter and Press the Power Button on the transmitter

Step 3 – Turn the DVR On

Step 4 – Match the channel selection between the DVR and Transmitter by turning the Channel Selector on the Transmitter until you see the targeting camera image on the DVR

Heads Up Display



The position of the display can be moved in multiple directions based on the preference of the user.



To make slight adjustments to the focus, adjust the diopter to the left or right using your index finger.

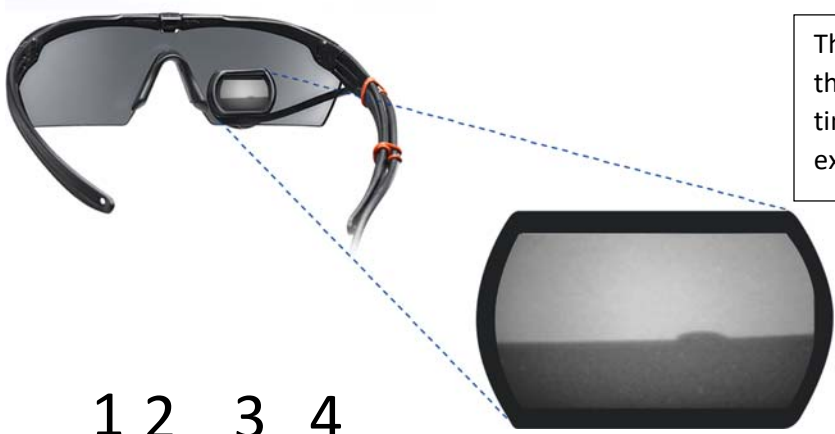

The standard configuration provides the image to your right eye. Clear or tinted lenses can be used based on external lighting conditions.



- 1) Micro-USB Charging Port
 - 2) Video Input
 - 3) Output to Heads-Up Display
 - 4) HDMI Input
 - 5) Power
 - 6) Reduce Brightness
 - 7) Increase Brightness
 - 8) Toggle Aspect Ratio (4:3 / 16:9)
 - 9) Toggle Color / B&W (OpenVision video output is only Black and White)
- NOTE: The PirateEye controller must be charged separately via USB Charger as it is not powered by the OpenVision system. Expected battery life is 10 hours.

Maintenance

The OVCF was designed to require minimal maintenance for the operator. All that is required is a daily visual inspection of the unit. Specific attention should be paid to the battery, the battery terminal on the controller ensuring they are clean and in solid mechanical shape. The controller cable / C-Arm Cable should be inspected for any cracks or wear. The Allen screw/ thumb screws should be checked for tightness and the imager bag should be checked for excessive wear.



Troubleshooting

Condition	Cause	Check	Correction
The light on the x-ray tube blinks repeatedly when the x-ray trigger is pressed or rapid short beeps continue for an extended period of time	Low battery	Battery life indicator on M18 battery	Change or charge battery
No output; the unit does not turn on with the controller energized	Controller cable	Ensure controller cable firmly attached	Change Cable
LCD display too dark or too light in center of display	Adjustment required on LCD device Adjustment required on kV and mA output	Adjust brightness and contrast using monitor Adjust kV and mA output using the push-buttons on the controller	Increase/reduce brightness and/or contrast setting Increase/reduce kV and/or mA output level
Low x-ray output or misaligned image	Loose C-Arm joints	Check for excessive movement in the joints with the C-arm extended	Tighten the Allen Screws
X-ray stops after 90 seconds of operation	Required Interlock		Allow the unit to cool for at least 90 seconds resume using as normal.



QSA Global Contact Information

Sales/Customer Service
6765 Langley Drive
Baton Rouge, LA 70809 USA

Telephone +1 225 751 5893
Toll Free +1 800 225 1383
Fax +1 225 756 0365

Manufacturing / International Service Center
40 North Avenue
Burlington, MA 01803 USA

Telephone +1 781 272 2000
Toll Free +1 800 815 1383
Fax +1 781 359 9179

North America Service Center
3200 Awesome Lane
LaPorte, TX 77571
Telephone +1 713 944 3200
Fax +1 281 476 9309

All goods and services are sold subject to the terms and conditions of QSA Global, Inc. A copy of these terms and conditions is available upon request.

OpenVision™ is a trademark of QSA Global, Inc.

All brand names and product names where used are acknowledged to be trademarks of their respective holders

©2017 QSA Global, Inc.



Appendix 1: Parts List

ID #	Part #	Description
1	OVCF-NDT-70B	OpenVision CF-NDT Complete System
2	315302	Imager Assembly
3	315304	Controller
4	313425	Controller Shoulder Strap
5	315289	7 in. LCD Monitor
6	315363	Head Mounted Display
7	315263	DVR Assembly w/ 4GB Micro SD card
8	315296	Wireless DVR Transmitter
9	315221	Controller cable 6ft
10	315225	Monitor Cable
11	315223	C-ARM cable
12	313426	External Trigger
13	313056	Controller Key
14	315201	18V Lithium-ion Battery
15	315202	Battery Charger (110V)
16	315207	Battery Charger (220V)
17	315204	Tool Kit
18	315206	OVCF Pelican Case W/ Foam
19	315205	C-ARM extension
20	315266	Handle
21	315075	Picatinny rail handle
22	315224	Imager bag
23	315127	Articulating Arm
24	315301	Tube Assembly

