

G35 Series

Maximum Flow Rate: 138 l/min (36.5 gpm)
Maximum Pressure: 103 bar (1500 psi) for Metallic Pump Heads

API 674



WANNER
Hydra-Cell[®]
Seal-less Pump Technology

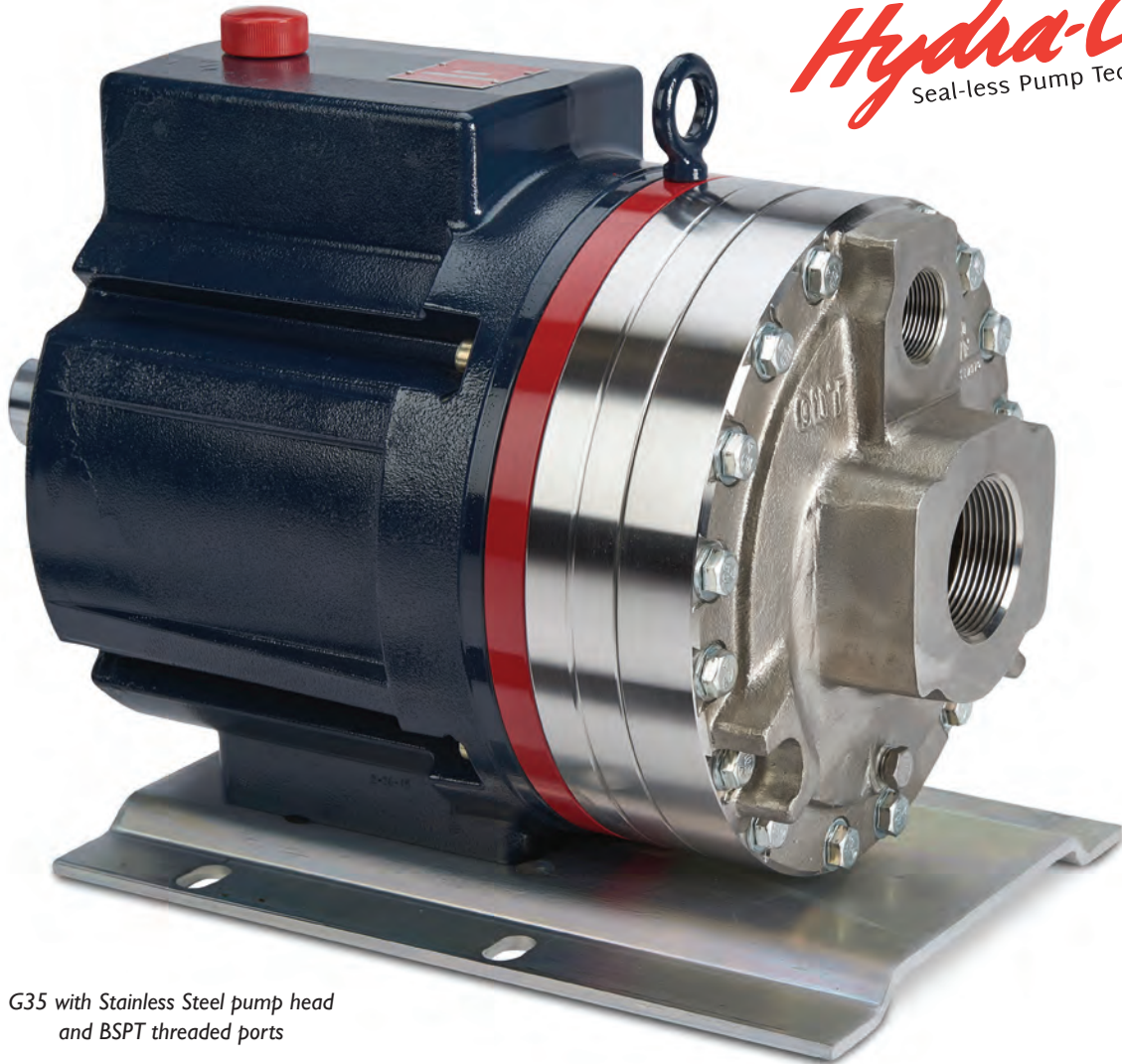

*G35 with Stainless Steel pump head
and BSPT threaded ports*



G35 with Cast Iron pump head



G35 with Brass pump head

G35 Series Performance

Capacities

Flow

Model	Max. Input rpm	Max. Flow	
		@ 83 bar (1200 psi) gpm	l/min
G35-X	1050	36.5	138
G35-E	1150	34.0	129
@ 103 bar (1500 psi)			
G35-X	700	24.6	93
G35-E	700	21.1	80

Pressure

Maximum Inlet Pressure

17 bar (250 psi) with 103 bar (1500 psi) maximum discharge pressure
34 bar (500 psi) with 83 bar (1200 psi) maximum discharge pressure

Maximum Discharge Pressure

83 bar (1200 psi) @ 1150 rpm max.
103 bar (1500 psi) @ 700 rpm max.

Performance and specification ratings apply to G35 configurations unless specifically noted otherwise.

Metering & Dosing

API 675 Performance Characteristics of Steady State Accuracy $\pm 1\%$, Linearity $\pm 3\%$ and Repeatability $\pm 3\%$ can be achieved at speeds up to 700 rpm and pressures up to 103 bar (metallic pump heads) or speeds up to 1050 rpm and pressures up to 83 bar (metallic pump heads) for X-cam pumps only.

Maximum Flow at Designated Pressure

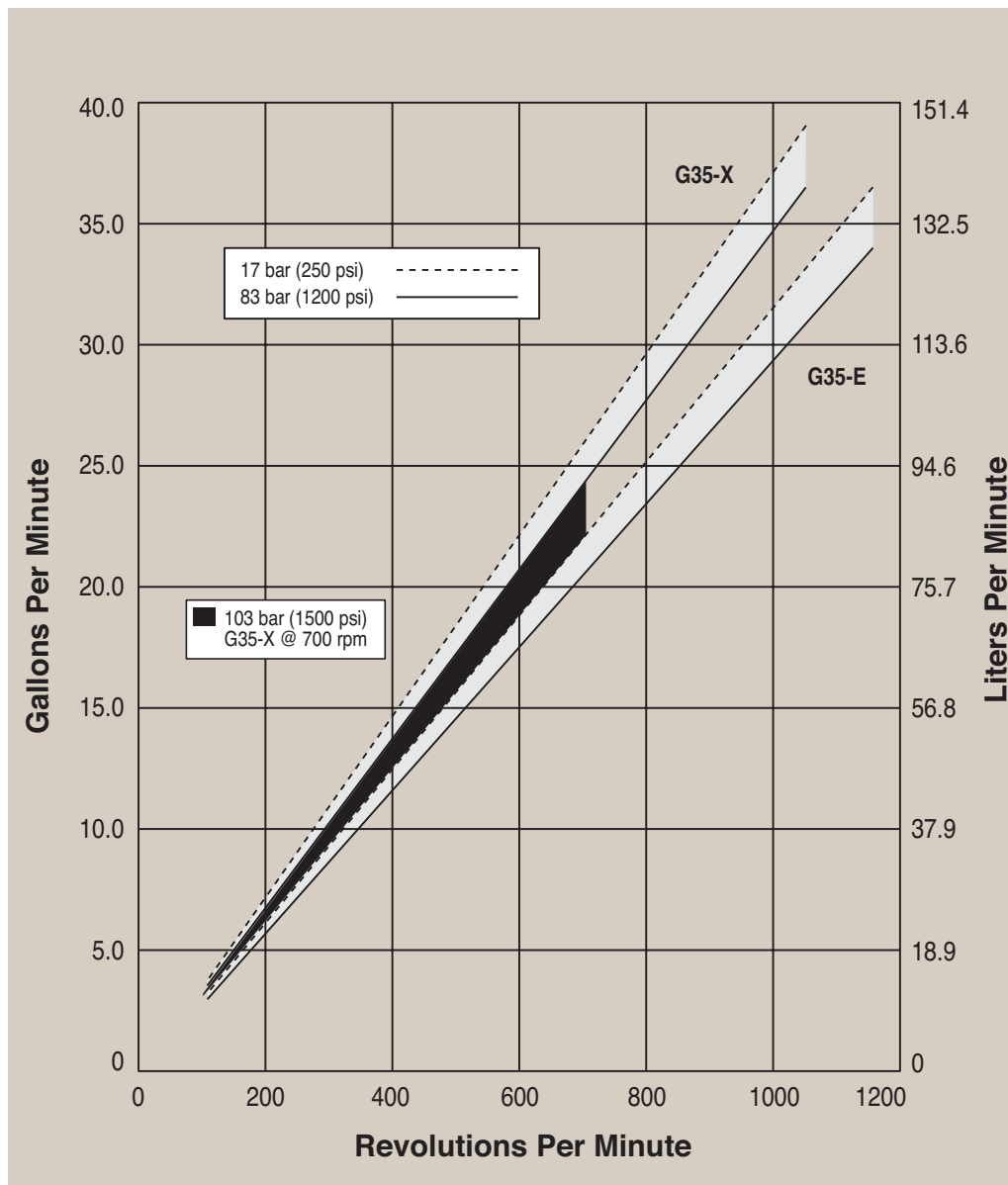

G35 Series API 674 Performance

Capacities

Flow

Model	Max. Input rpm	Max. Flow @ 83 bar (1200 psi)	
		gpm	l/min
G35-X	1050	36.5	138
G35-E	1150	34.0	129

Pressure

Maximum Inlet Pressure

34 bar (500 psi) with 83 bar (1200 psi) maximum discharge pressure

Maximum Discharge Pressure

83 bar (1200 psi) @ 300 rpm max.

Performance and specification ratings apply to G35 configurations unless specifically noted otherwise.

Maximum RPM at Designated Pressure

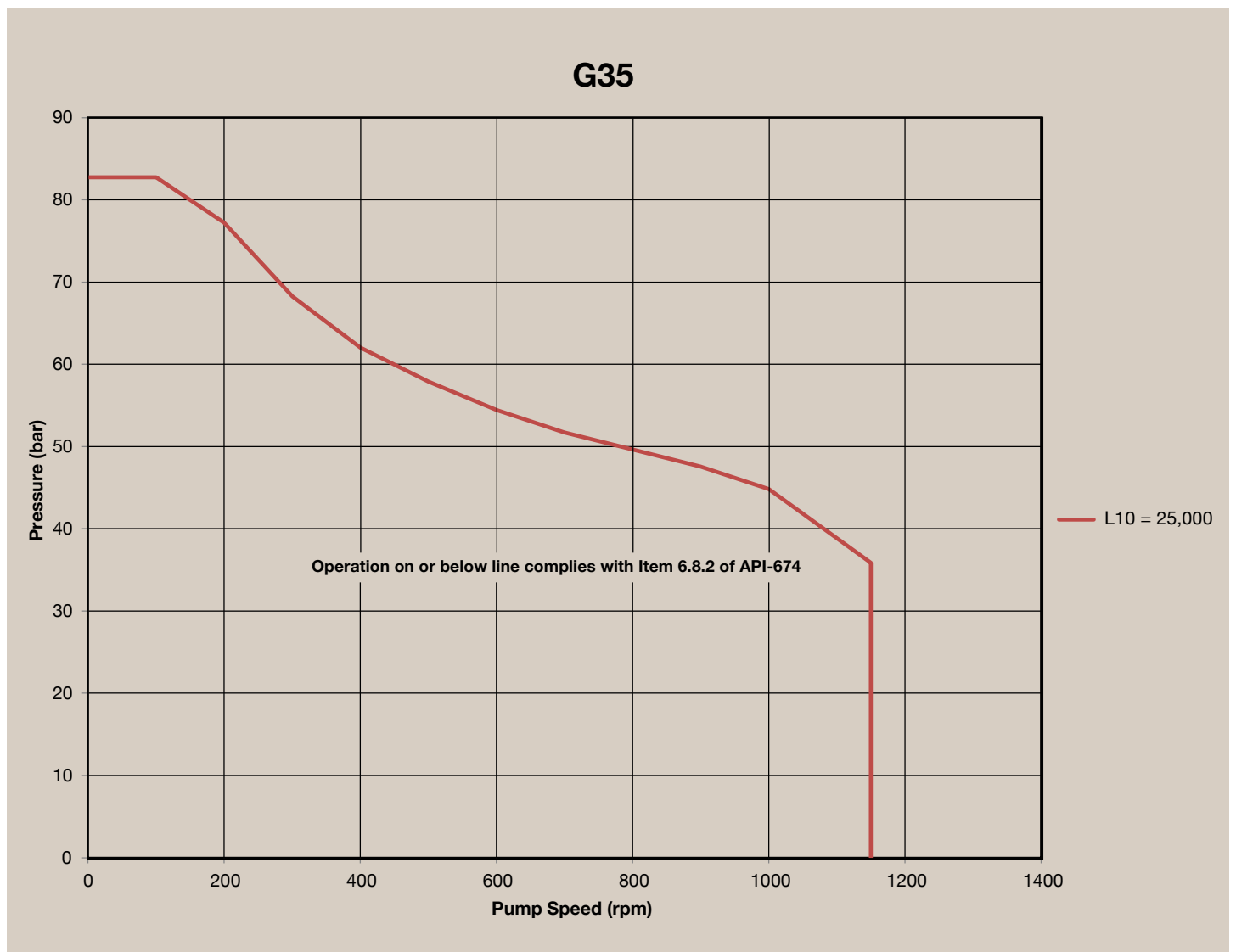

G35 Series Specifications

Flow Capacities @ 83 bar (1200 psi) 6-pole Motor @ 50 Hz

Model	rpm	gpm	l/min
G35-X	960	33.50	127.00
G35-E	960	29.00	110.00

Flow Capacities @ 83 bar (1200 psi) 8-pole Motor @ 50 Hz

Model	rpm	gpm	l/min
G35-X	730	25.50	96.60
G35-E	730	22.10	83.60

Delivery @ 83 bar (1200 psi)

Model	gal/rev	liters/rev
G35-X	0.0347	0.1314
G35-E	0.0296	0.1120

Delivery @ 103 bar 1500 psi

Model	gal/rev	liters/rev
G35-X	0.0330	0.1250

Maximum Discharge Pressure

Metallic Heads: 103 bar (1500 psi) @ 700 rpm

Maximum Inlet Pressure 17 bar (250 psi) with 103 bar (1500 psi) maximum discharge pressure
34 bar (500 psi) with 83 bar (1200 psi) maximum discharge pressure

Maximum Operating Temperature

Metallic Heads: 121 °C (250 °F) - Consult factory for correct component selection for temperatures from 71 °C (160 °F) to 121 °C (250 °F).

Maximum Solids Size 800 microns

Inlet Port 2-1/2 inch BSPT
2-1/2 inch NPT
150lb or 600lb ANSI RF Flange
3 inch SAE

Discharge Port 1-1/4 inch BSPT
1-1/4 inch NPT
600lb or 1500lb ANSI RF Flange
1-1/4 inch SAE

Shaft Diameter 50.8 mm (2 inch)

Shaft Rotation Reverse (bi-directional)

Bearings Tapered roller bearings

Oil Capacity 7.3 litres (7.75 US quarts)

Weight
Metallic Heads: 257 lbs. (116.6 kg)

Calculating Required Power

$$\frac{100 \times \text{rpm}}{63,000} + \frac{\text{gpm} \times \text{psi}}{1,460} = \text{electric motor hp}$$

$$\frac{100 \times \text{rpm}}{84,428} + \frac{\text{l/min} \times \text{bar}}{511} = \text{electric motor kW}$$

Calculating Pulley Size

$$\frac{\text{motor pulley OD}}{\text{pump rpm}} = \frac{\text{pump pulley OD}}{\text{motor rpm}}$$

When using a variable frequency controller (VFD) calculate the hp or kW at minimum and maximum pump speed to ensure the correct hp or kW motor is selected. Note that motor manufacturers typically de-rate the service factor to 1.0 when operating with a VFD.

Net Positive Suction Head (NPSHr)

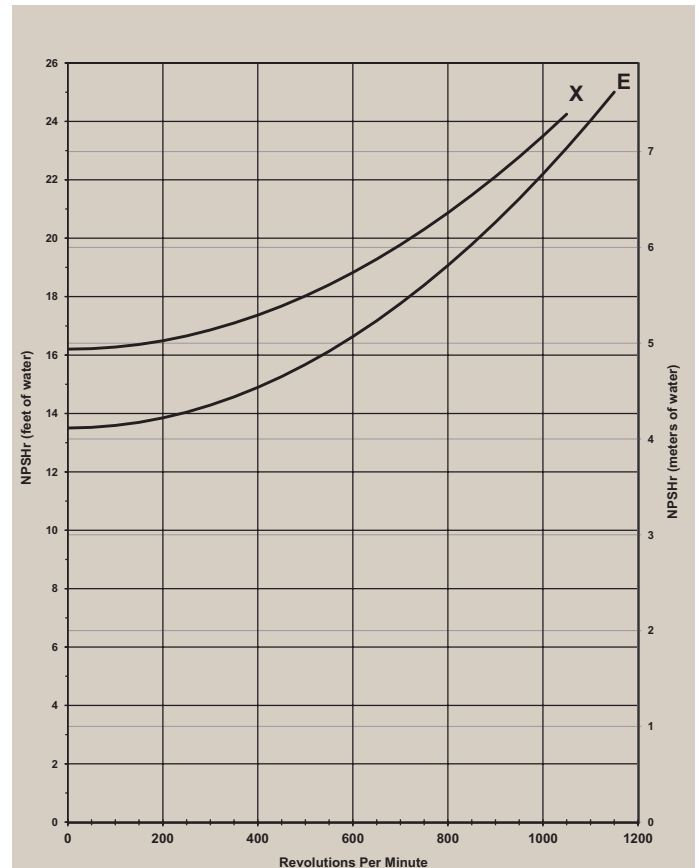

Note: Positive inlet pressure required with PTFE diaphragms.

Self-priming:

Each Hydra-Cell pump has different lift capability depending on model size, cam angle, speed, and fluid characteristics. To ensure that your specific lift characteristics are met, refer to the inlet calculations regarding friction, and acceleration head losses in your Hydra-Cell Installation & Service Manual. Compare those calculations to the NPSHr curves above.

G35 Series General Assemblies

Baseplate Assembly Long-coupled for IEC 132 Motor Frame

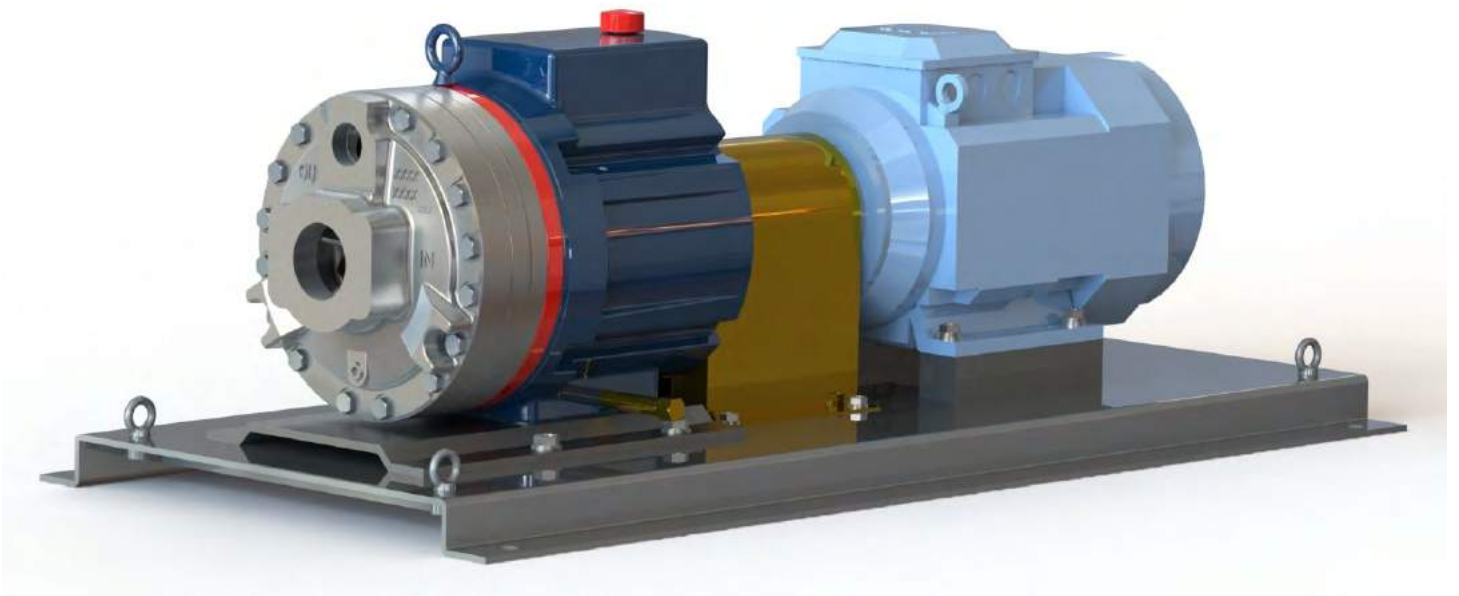

Dimensions in mm

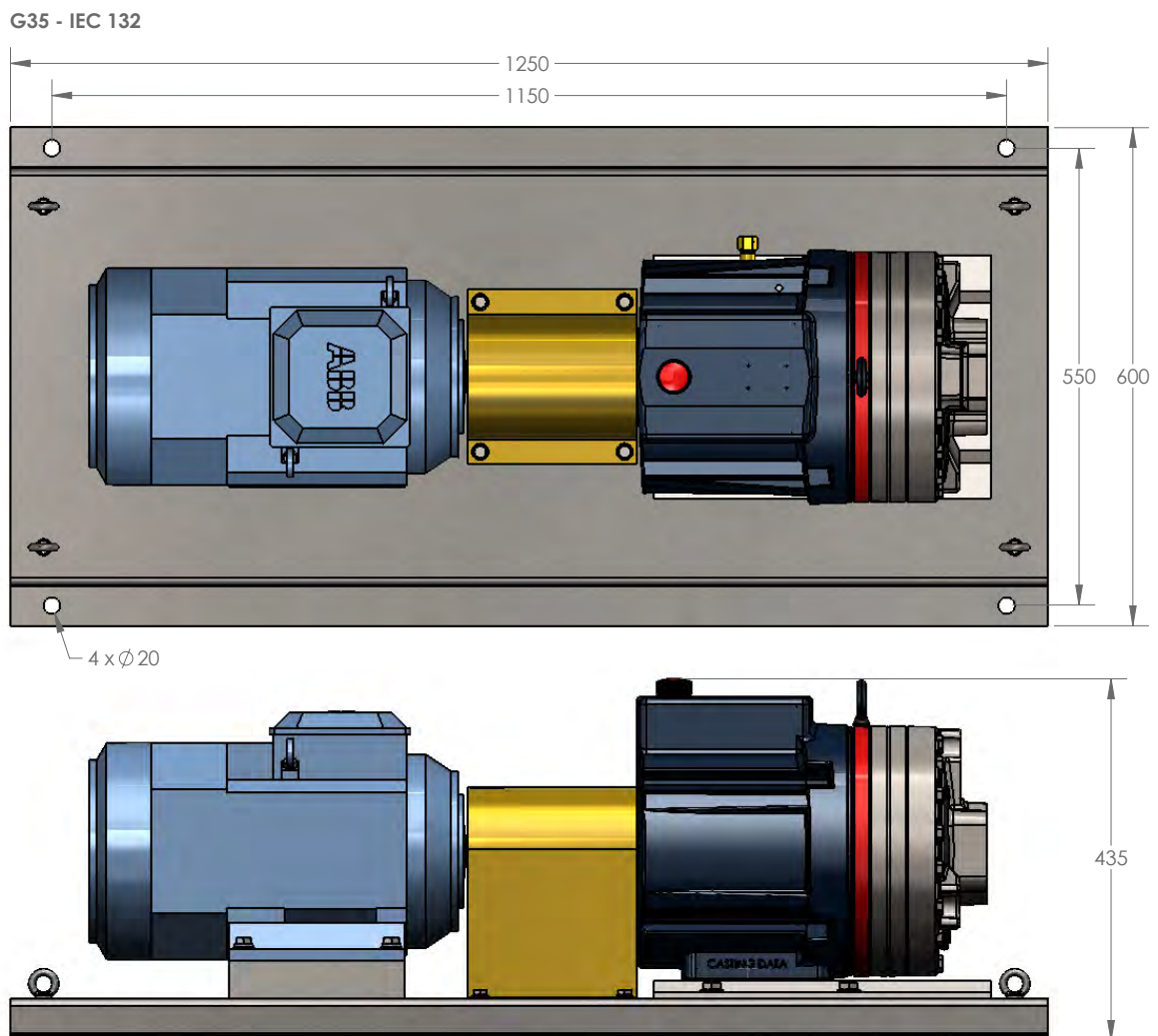

Unit Weight Approx - 261 Kg

G35 Series General Assemblies

Baseplate Assembly Long-coupled for IEC 160 Motor Frame

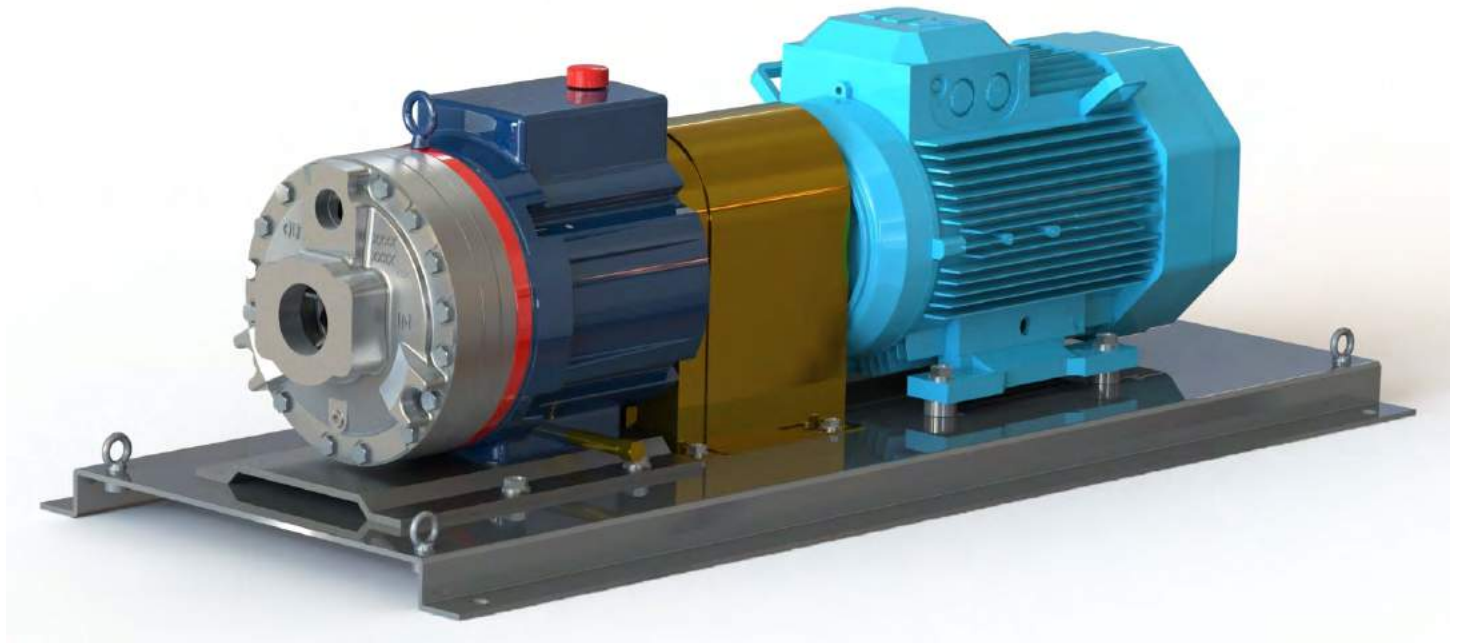

Dimensions in mm

G35 - IEC 160

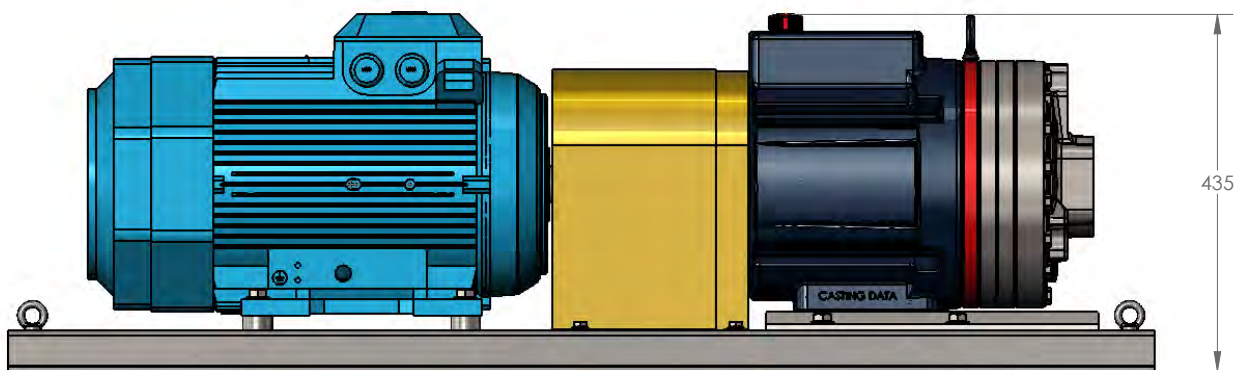
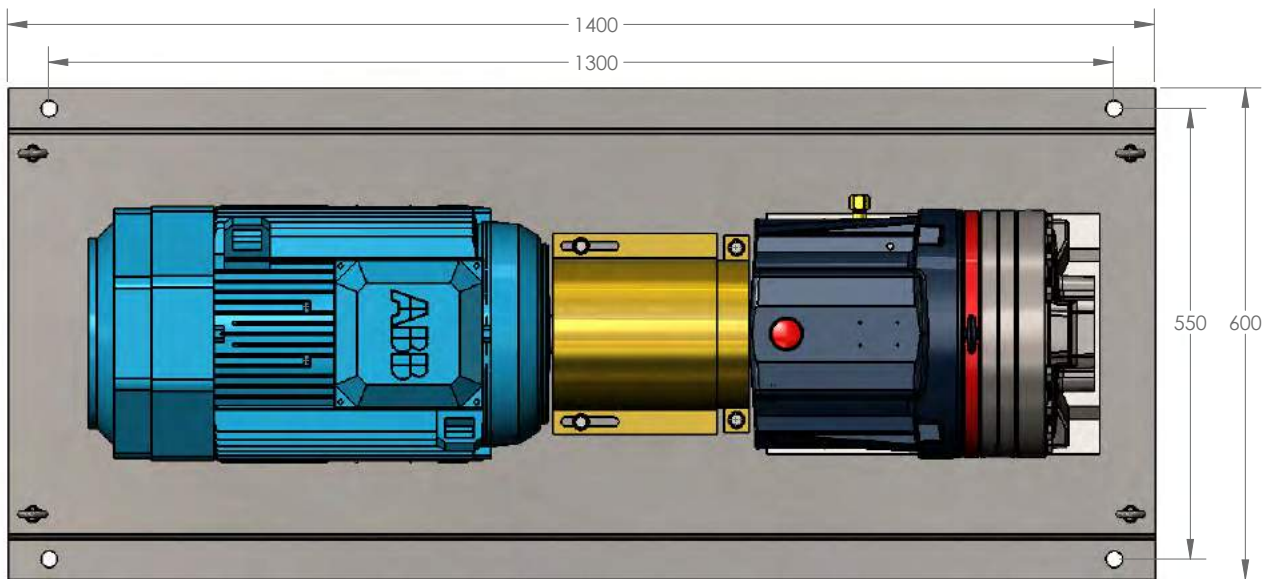

Unit Weight Approx - 358 Kg

G35 Series General Assemblies

Baseplate Assembly Long-coupled for IEC 180 Motor Frame

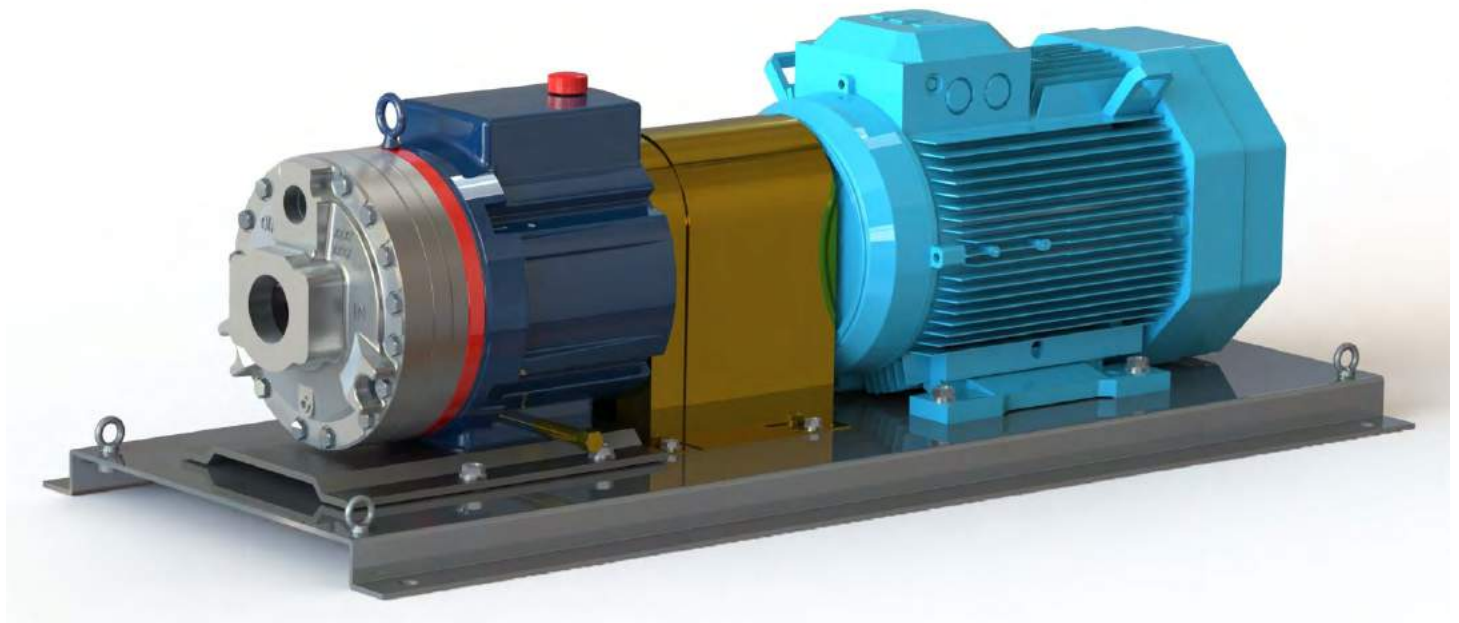

Dimensions in mm

G35 - IEC 180

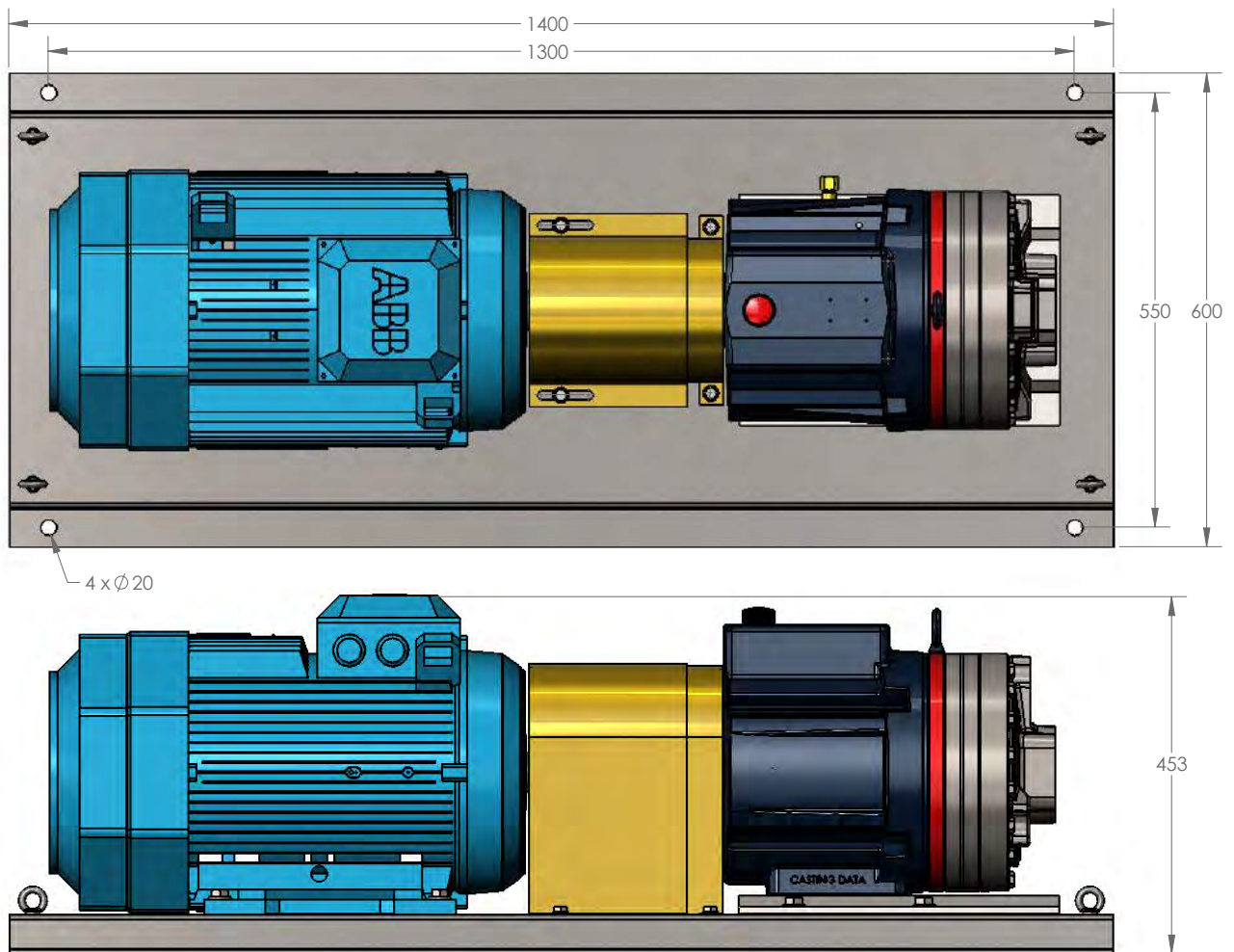

Unit Weight Approx - 393 Kg

G35 Series General Assemblies

Baseplate Assembly Long-coupled for IEC 200 Motor Frame

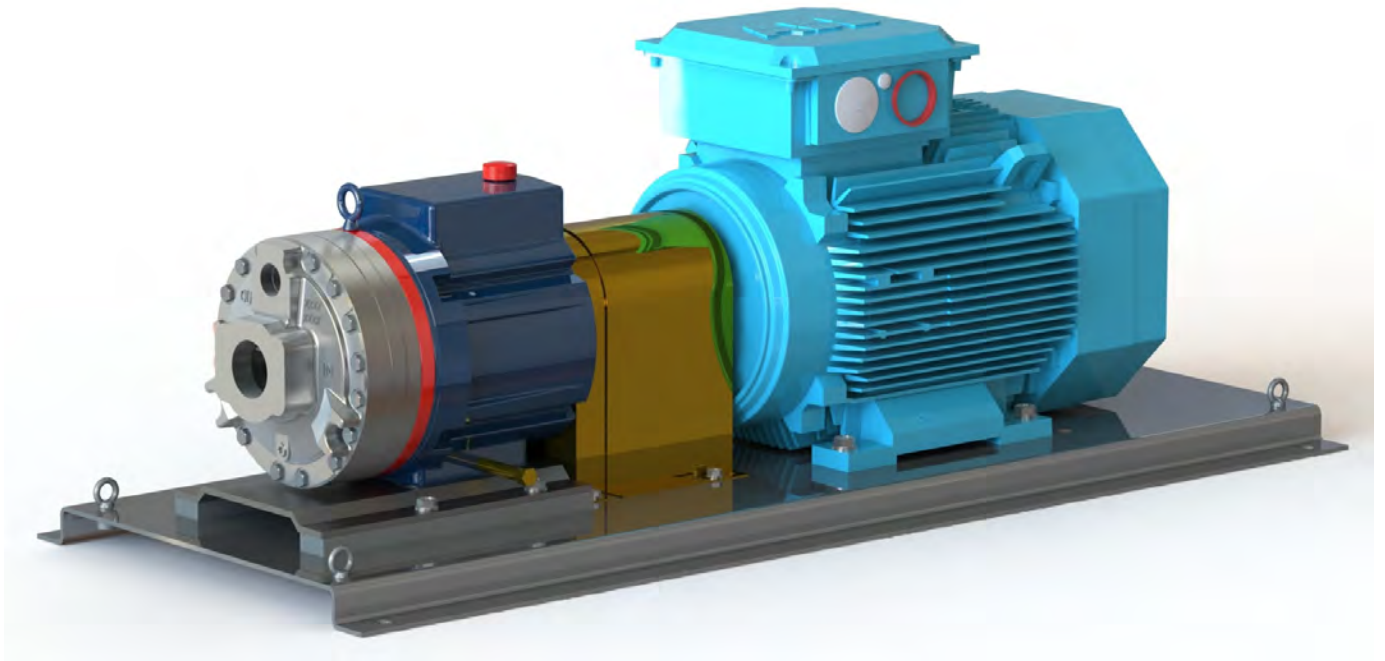

Dimensions in mm

G35 - IEC 200

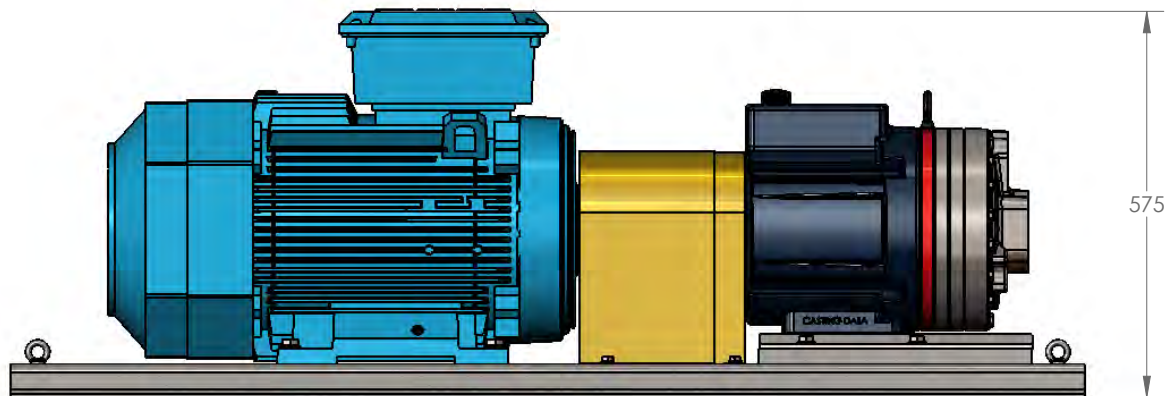
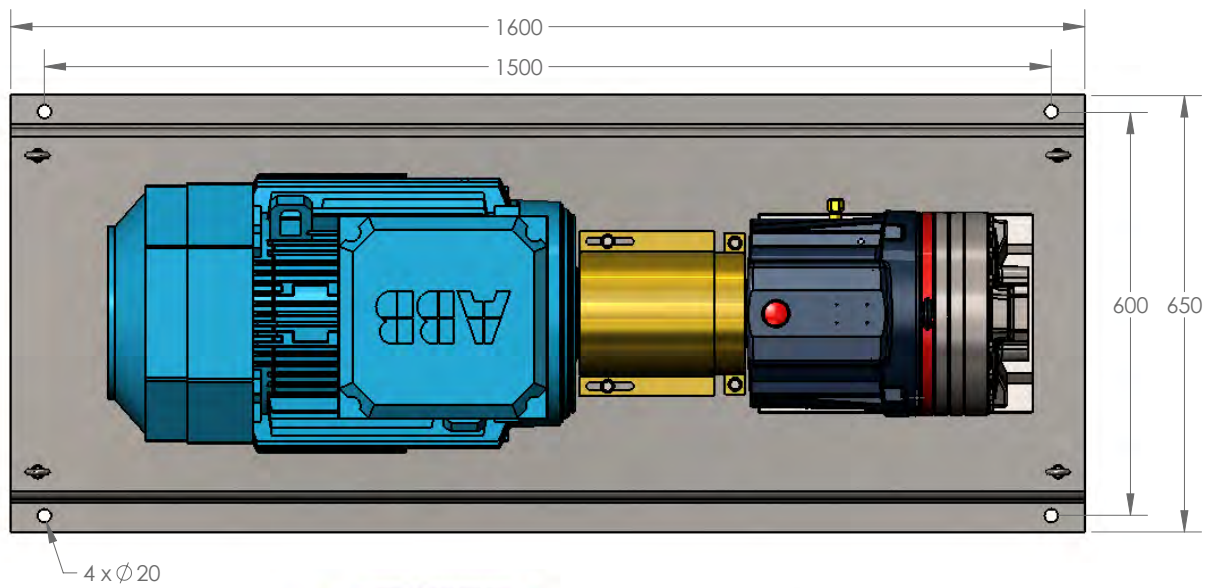

Unit Weight Approx - 488 Kg

G35 Series General Assemblies

Baseplate Assembly Long-coupled for IEC 225 Motor Frame

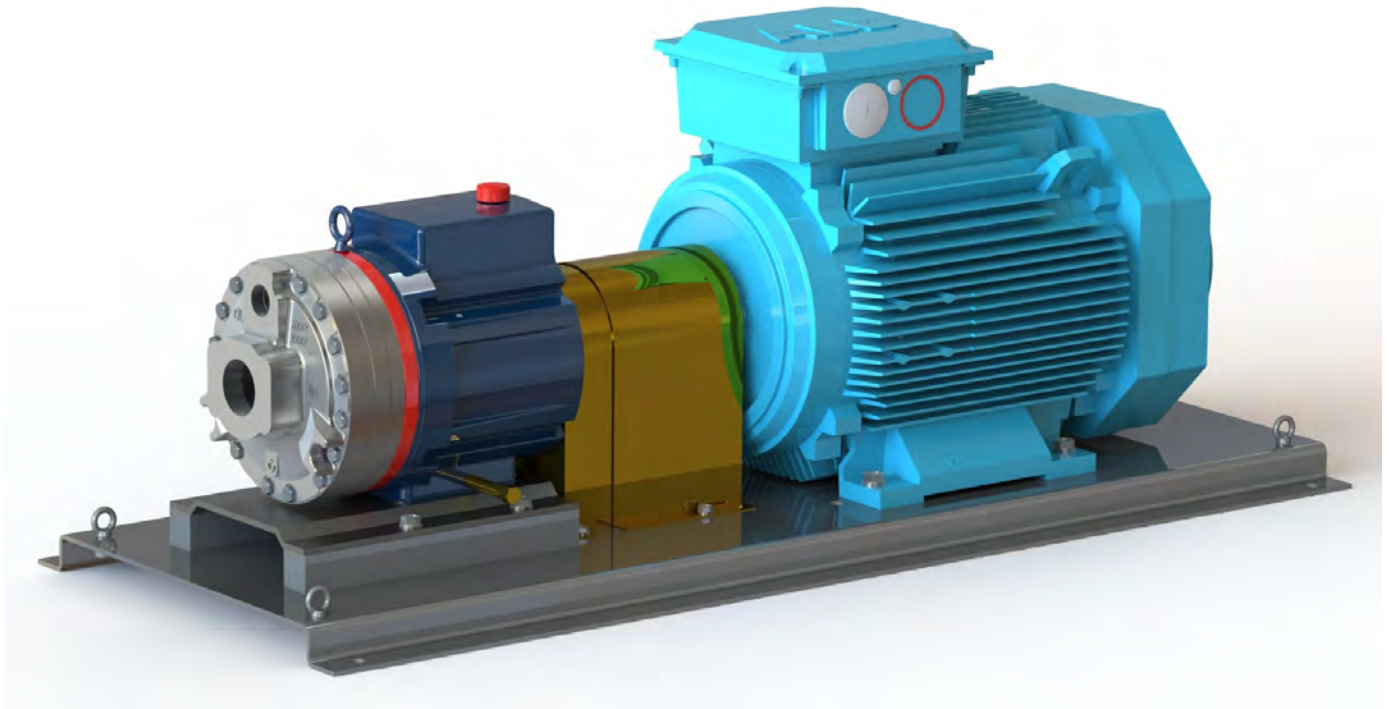

Dimensions in mm

G35 - IEC 225

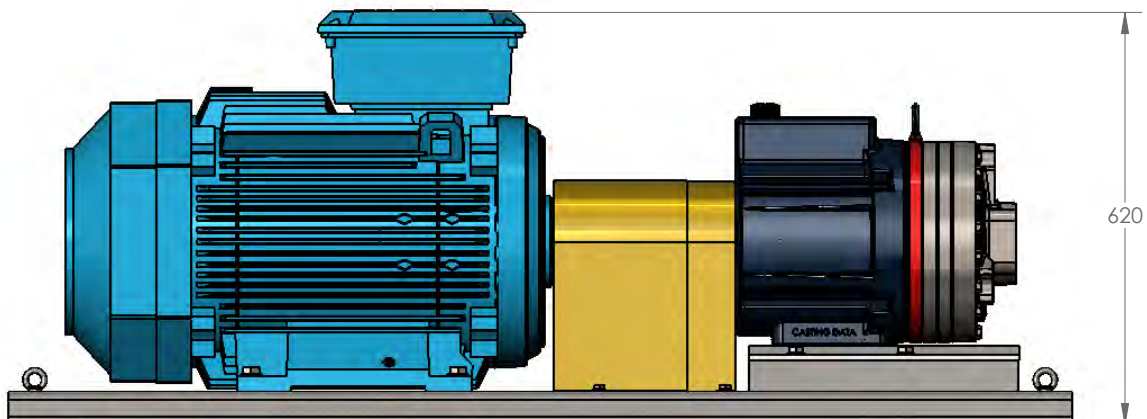
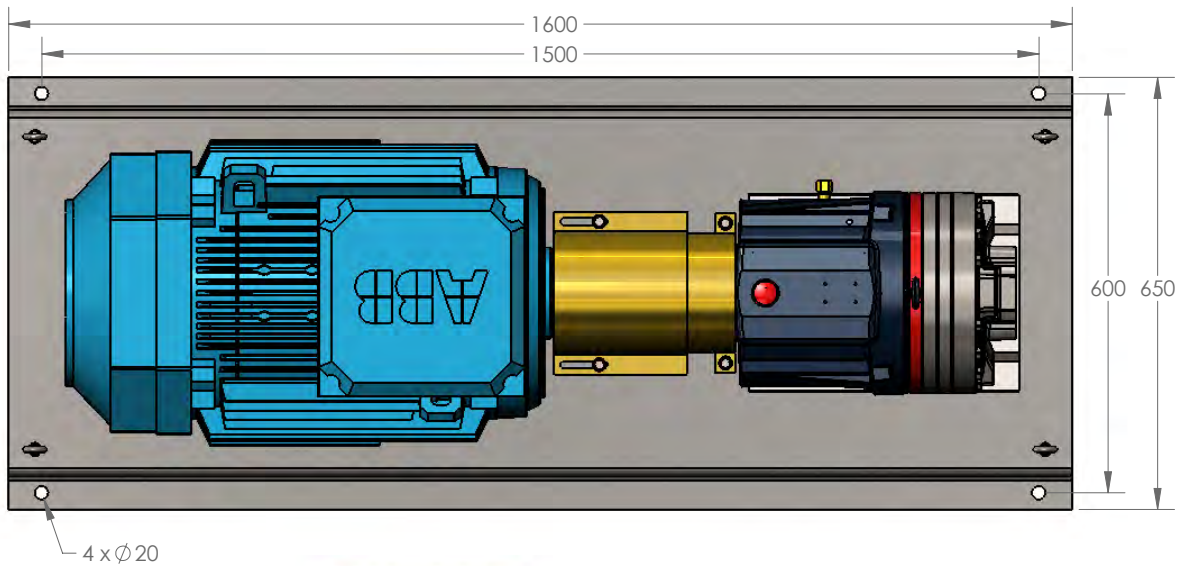

Unit Weight Approx - 546 Kg

G35 Series Representative Drawings

G35 Models with NPT Inlet/Outlet Ports mm (Inches)

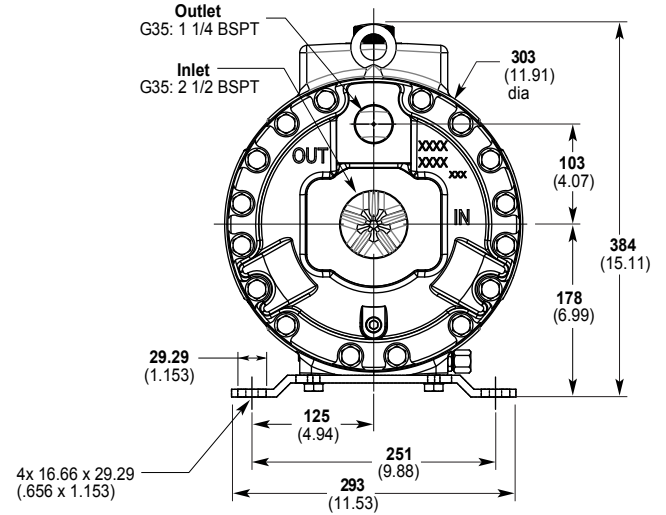
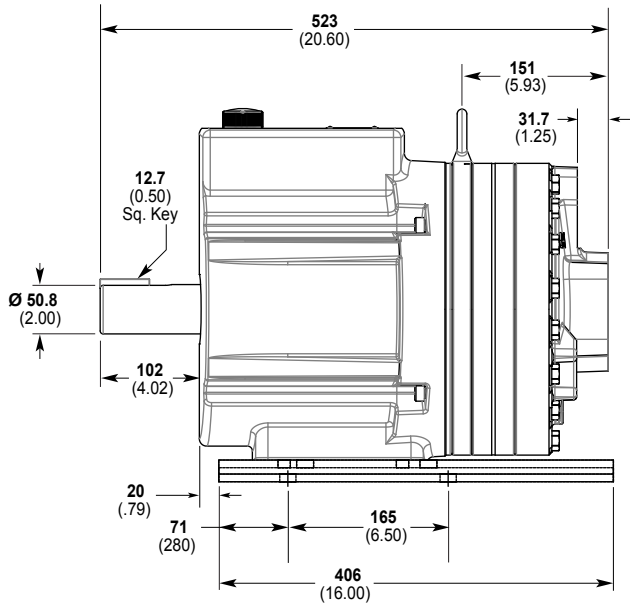

G35 Models with SAE Flange Inlet/Outlet Ports mm (Inches)

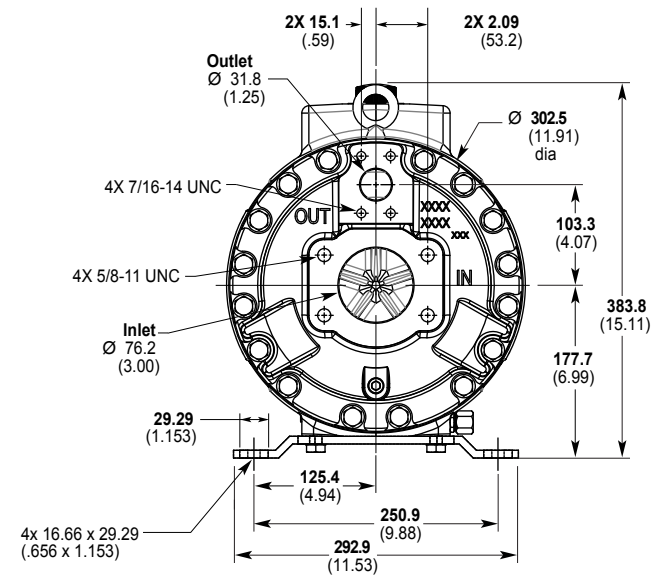
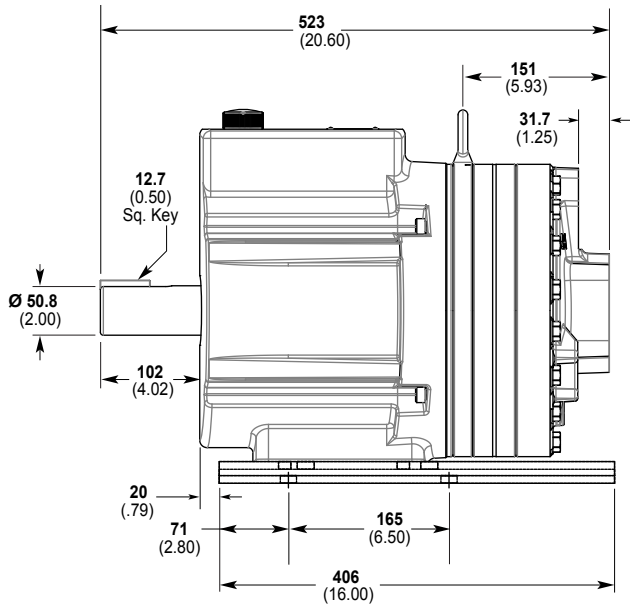

Note: Contact factory for additional drawings of specific models and configurations.

G35 Series Representative Drawings

G35 Models with ANSI RF Flange Inlet/Outlet Ports mm (Inches)

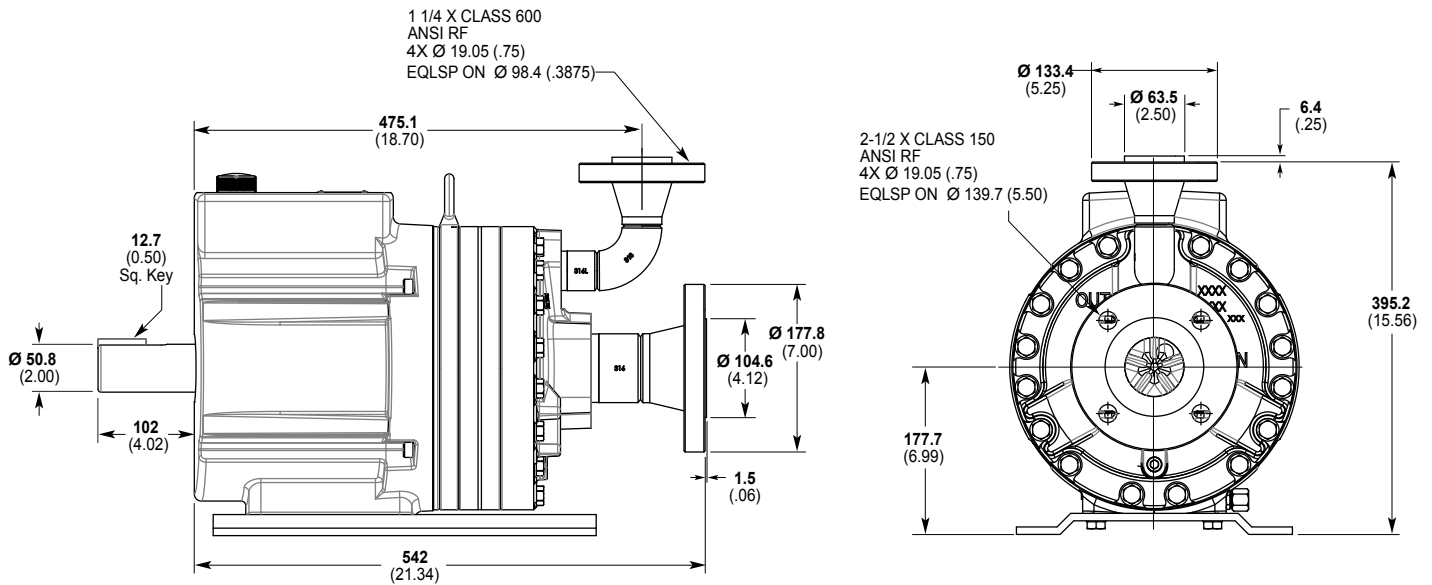

G35 Models with Tri-clamp Flanges mm (Inches)

Maximum Discharge Pressure: 80 bar

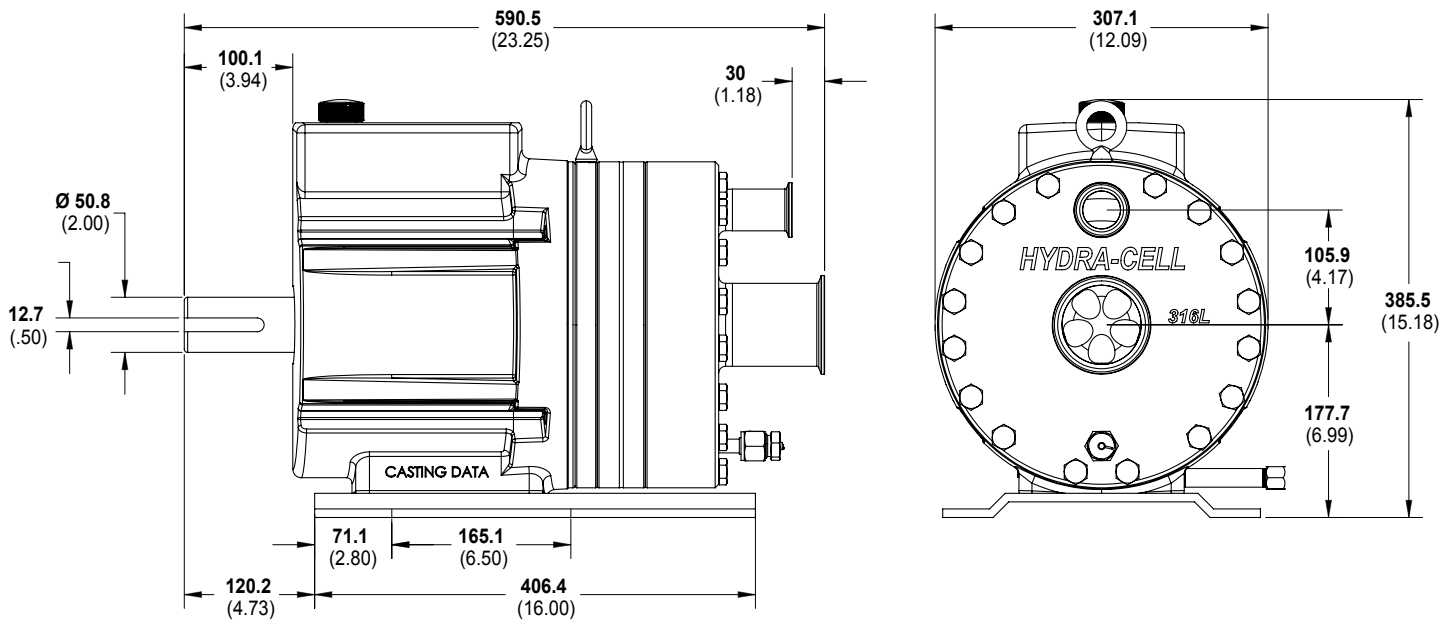

G35 Series Valves

Valve Selection

A seal-less C64 Pressure Regulating Valve is recommended for Hydra-Cell G35 pumping systems, especially for high-pressure requirements or when handling dirty fluids.



A C24 Pressure Regulating Valve provides a capable, lower-cost alternative to C64 valves for Hydra-Cell G35 pumping systems.



G35 Series How to Order

Ordering Information

1	2	3	4	5	6	7	8	9	10	11	12
G	3	5									

A complete G35 Series Model Number contains 12 digits including 9 customer-specified design and materials options, for example: G35XKBTHFECA.

Digit	Order Code	Description
1-3	G35	Pump Configuration Shaft-driven (BSPT Ports)
	D35	Shaft-driven (NPT Ports or ANSI Flanges or SAE Flanged Ports)
4	X	Hydraulic End Cam Max 127.0 l/min (33.5 gpm) @ 960 rpm
	E	Max 110.0 l/min (29.1 gpm) @ 960 rpm
5	K	Pump Head Version Kel-Cell (BSPT Ports or ANSI Flanges)
	E	Kel-Cell (SAE Flanged Ports - only supplied with D35 pumps)
	-	ATEX 2014/34/EU Certified, Category 2, Zone 1, Hazardous Liquids
	-	ATEX 2014/34/EU Certified, Category 2, Zone 1, Non-Hazardous Liquids
	-	ATEX 2014/34/EU Certified, Category 3, Zone 2 <i>Note: All options include Certificate, Oil Level Monitor or Sight Glass, Earth Stud & Secondary ATEX Label.</i>
6	B	Pump Head Material Brass
	C	Cast Iron (Nickel-plated)
	G	Duplex Alloy 2205 (with Hastelloy C followers & follower screws)
	Q	316L Stainless Steel with ANSI RF Flanges, Class 600lb x 1500lb
	R	316L Stainless Steel with ANSI RF Flanges, Class 150lb x 600lb
	S	316L Stainless Steel (Threaded or SAE Ports)
	-	316L Stainless Steel with Tri-clamp (3" Inlet & 1-1/2" Discharge) Flanges polished to 0.8 Ra♦
	-	316L Stainless Steel with Tri-clamp (3" Inlet & 1-1/2" Discharge) Flanges polished to 0.4 Ra♦ <i>Tri-clamp options include polishing of Pump Head, Valve Plate, Valves, Valve Seats, Springs & Retainers to 0.8 Ra or 0.4 Ra per above, Sanitary Drain along with TSE, Passivation, Surface Finish & Weld Procedure Certificates</i>
	T	Hastelloy CW12MW ♦Selecting this option will result in a Wanner International generated Pump Code, stamped onto the pump.
	7	A
E		EPDM (requires EPDM-compatible oil - Digit 12 oil code D)
G		FKM
J		PTFE (available with E cam only; 1050 rpm max.)
K		FFKM diaphragm / PTFE o-ring
P		Neoprene
T		Buna-N
8	C	Valve Seat Material Ceramic
	D	Tungsten Carbide
	H	17-4 Stainless Steel
	N	Nitronic 50
	T	Hastelloy C

Digit	Order Code	Description
9	C	Valve Material Ceramic
	D	Tungsten Carbide
	F	17-4 Stainless Steel
	N	Nitronic 50
10	T	Hastelloy C
	E	Valve Springs Elgiloy
	H	17-7 Stainless Steel
11	T	Hastelloy C
	C	Valve Spring Retainers Celcon
	H	17-7 Stainless Steel
	M	PVDF
	P	Polypropylene
12	T	Hastelloy C
	Y	Nylon (Zytel)
	A	Hydra-Oil 10W30 standard-duty oil
	B	40-wt for continuous-duty oil (use with 316L SST or Hastelloy CW12MW pump head - standard)
	D	EPDM-compatible oil
	E	Food-contact oil
	G	5W30 cold-temp severe-duty synthetic oil
	H	15W50 high-temp severe-duty synthetic oil

G35 Pump Housing is standard as Cast Aluminum. Upgrade to Ductile Iron available.





WANNER ENGINEERING - WORLD HEADQUARTERS & MANUFACTURING
Minneapolis USA
t: (612) 332-5681
e: sales@wannereng.com

WANNER PUMPS
Kowloon HONG KONG
t: +852 3428 6534
e: sales@wannerpumps.com

WANNER INTERNATIONAL
Hampshire UK
t: +44 (0) 1252 816847
e: sales@wannerint.com

WANNER ENGINEERING
Latin American Office
t: +55 (11) 4081-7098
e: sales@wannereng.com

WANNER PUMPS
Shanghai CHINA
t: +86-21-6876 3700
e: sales@wannerpumps.com