

G15 Series

Maximum Flow Rate: 58.7 l/min (15.5 gpm)

Maximum Pressure: 172 bar (2500 psi) for Metallic Pump Heads

API 674



WANNER
Hydra-Cell[®]
Seal-less Pump Technology

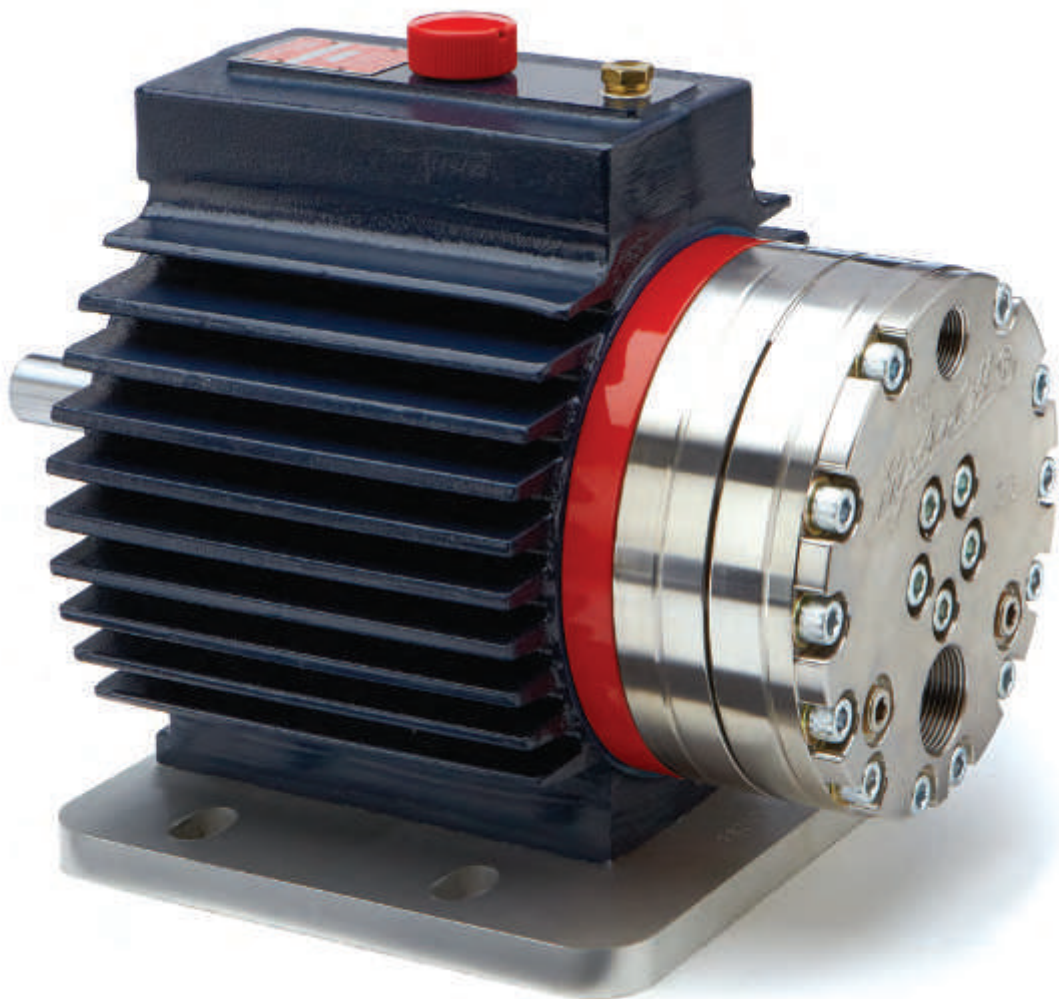

G15 for horizontal installations shown with Stainless Steel pump head.

G15 Series Performance

Capacities

Model	Max. Input rpm	Flow		Pressure	
		gpm	l/min	Max. Inlet Pressure	Max. Discharge Pressure
G15-X	1450	13.8	52.3	34 bar (500 psi)	34 bar (500 psi)
	1450	13.3	50.2	34 bar (500 psi)	103 bar (1500 psi)
	1450	13.0	49.2	34 bar (500 psi)	138 bar (2000 psi)
	1150	10.1	38.1	34 bar (500 psi)	172 bar 2500 psi)
G15-E	1750	15.5	58.7	34 bar (500 psi)	34 bar (500 psi)
	1750	14.8	56.2	34 bar (500 psi)	103 bar (1500 psi)
	1450	12.0	45.5	34 bar (500 psi)	138 bar (2000 psi)

Performance and specification ratings apply to G15 configurations unless specifically noted otherwise.

Maximum Flow at Designated Pressure

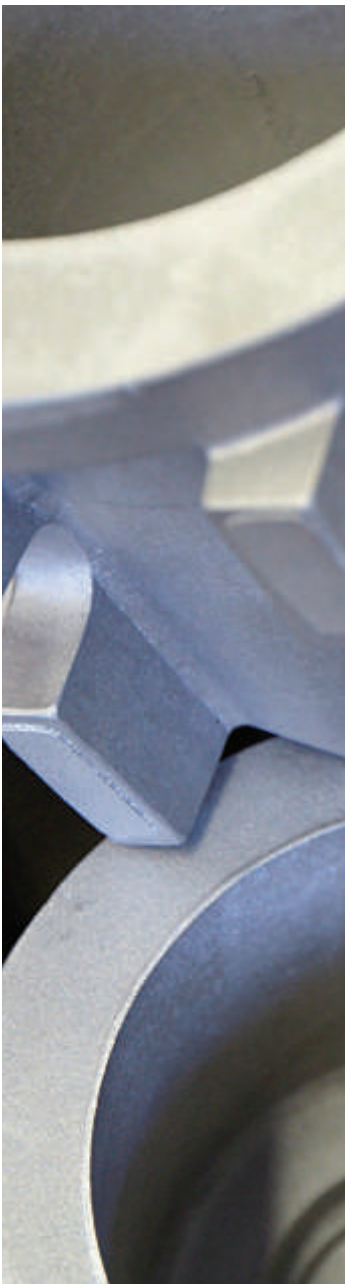
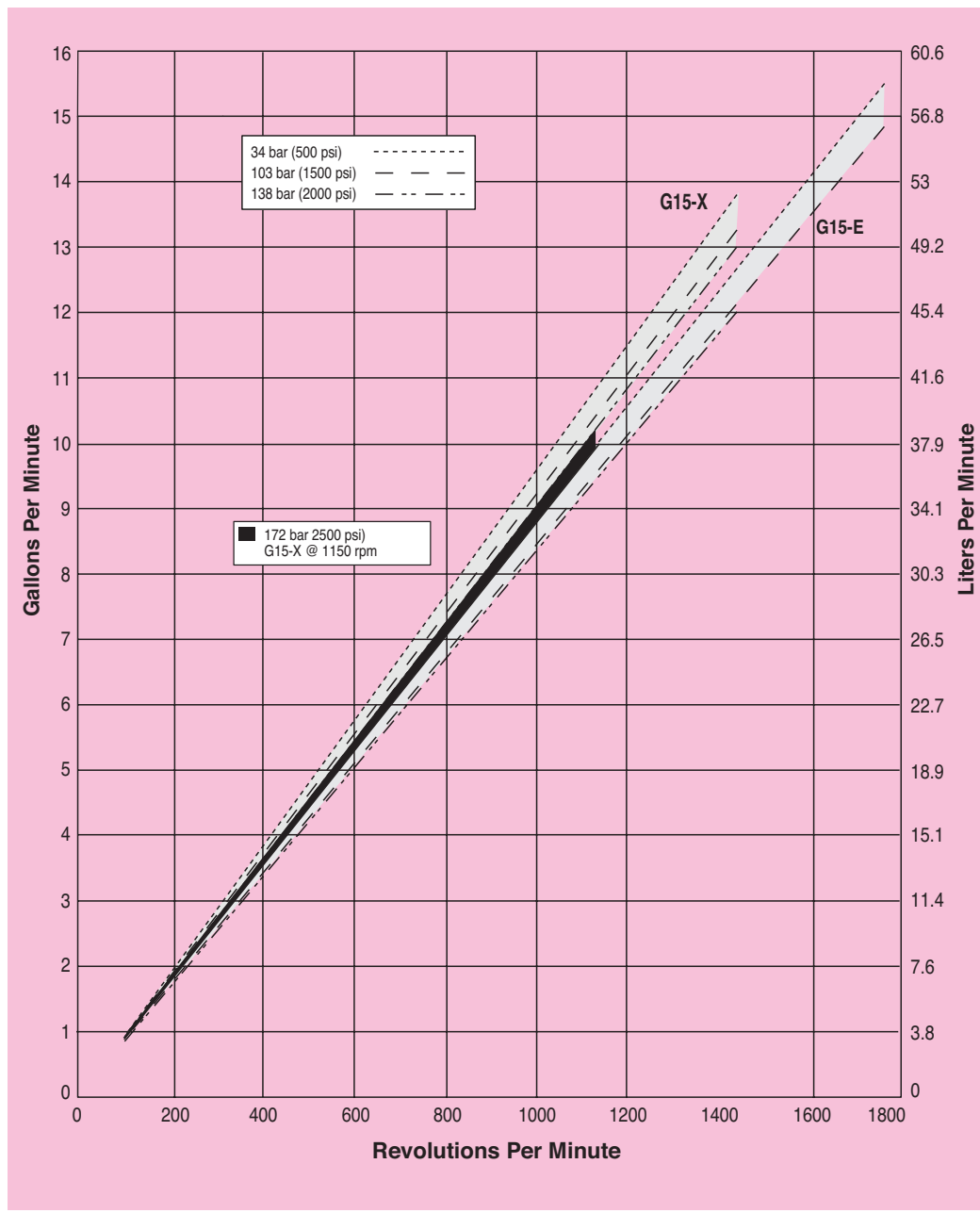

G15 Series Specifications

Flow Capacities (4-pole Motor @ 50 Hz)

Model	@ max rpm	psi	bar	gpm	l/min
G15-X	1450	500	34	13.8	52.3
	1450	1500	103	13.3	50.2
	1450	2000	138	13.0	49.2
	1150	2500	172	10.1	38.1
G15-E	1750	500	34	15.5	58.7
	1750	1500	103	14.8	56.2
	1450	2000	138	12.0	45.5

Delivery

Model	psi	bar	gal/rev	liters/rev
G15-X	500	34	0.0095	0.0360
	1500	103	0.0092	0.0346
	2000	138	0.0090	0.0339
	2500	172	0.0088	0.0331
G15-E	500	34	0.0089	0.0335
	1500	103	0.0085	0.0321
	2000	138	0.0083	0.0314

Maximum Discharge Pressure

Metallic Heads: 103 bar (1500 psi) @1750 rpm (G15-E only)
 138 bar (2000 psi) @1450 rpm
 172 bar (2500 psi) @1150 rpm

Maximum Inlet Pressure 500 psi (34 bar)

Maximum Operating Temperature

Metallic Heads: 121 °C (250 °F) - Consult factory for correct component selection for temperatures from 71 °C (160 °F) to 121 °C (250 °F).

Maximum Solids Size 500 microns

Inlet Port 1-1/4 inch BSPT 1-1/4 inch NPT

Discharge Port 3/4 inch BSPT 3/4 inch NPT

Shaft Diameter 28.58 mm (1-1/8 inch)

Shaft Rotation Reverse (bi-directional)

Bearings Tapered roller bearings

Oil Capacity 2.1 liters (2.2 US quarts)

Weight

Metallic Heads: 145 lbs. (66 kg)

Calculating Required Power

$$\frac{80 \times \text{rpm}}{63,000} + \frac{\text{gpm} \times \text{psi}}{1,460 - \left(\frac{\text{psi} - 500}{20}\right)} = \text{electric motor hp}$$

$$\frac{80 \times \text{rpm}}{84,428} + \frac{\text{l/min} \times \text{bar}}{511 - \left(\frac{\text{bar} - 35}{4}\right)} = \text{electric motor kW}$$

Calculating Pulley Size

$$\frac{\text{motor pulley OD}}{\text{pump rpm}} = \frac{\text{pump pulley OD}}{\text{motor rpm}}$$

When using a variable frequency controller (VFD) calculate the hp or kW at minimum and maximum pump speed to ensure the correct hp or kW motor is selected. Note that motor manufacturers typically de-rate the service factor to 1.0 when operating with a VFD.

Net Positive Suction Head (NPSHr)

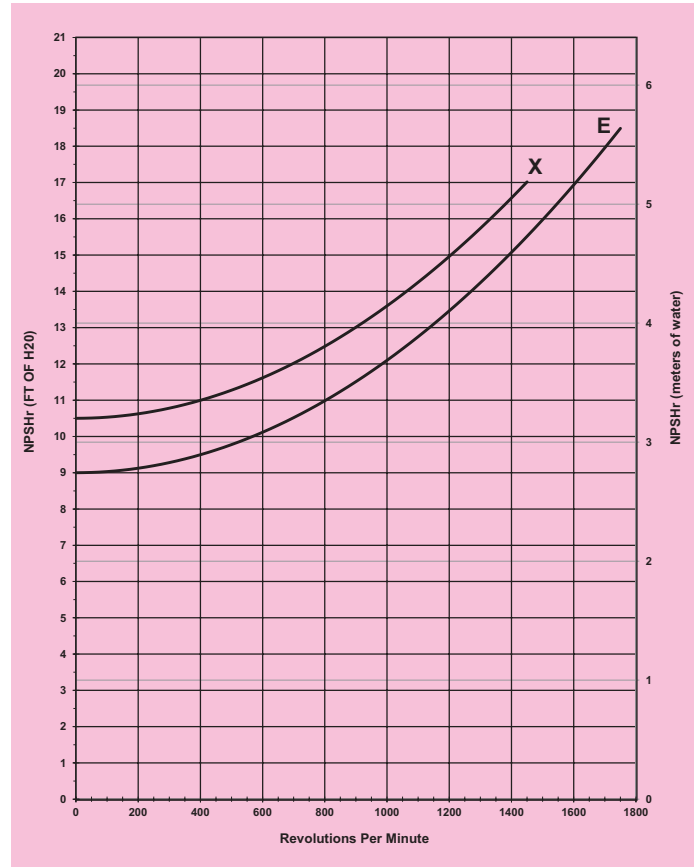

Self-priming:

Each Hydra-Cell pump has different lift capability depending on model size, cam angle, speed, and fluid characteristics. To ensure that your specific lift characteristics are met, refer to the inlet calculations regarding friction, and acceleration head losses in your Hydra-Cell Installation & Service Manual. Compare those calculations to the NPSHr curves above.

G15 Series Representative Drawings

G15 Models with Metallic Pump Head mm (Inches)

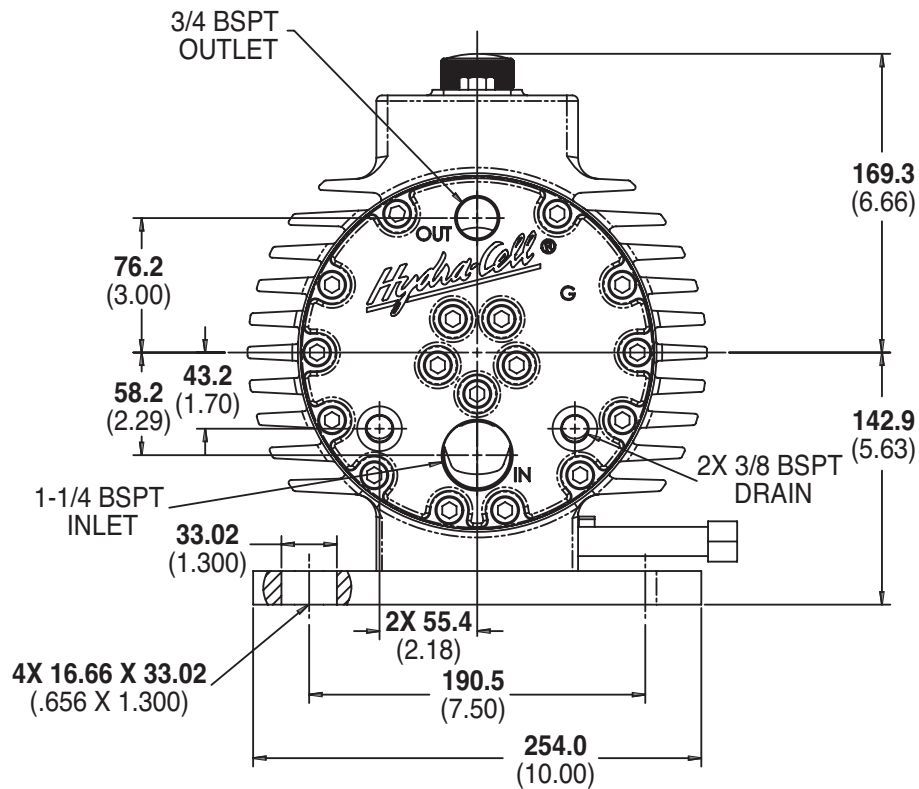
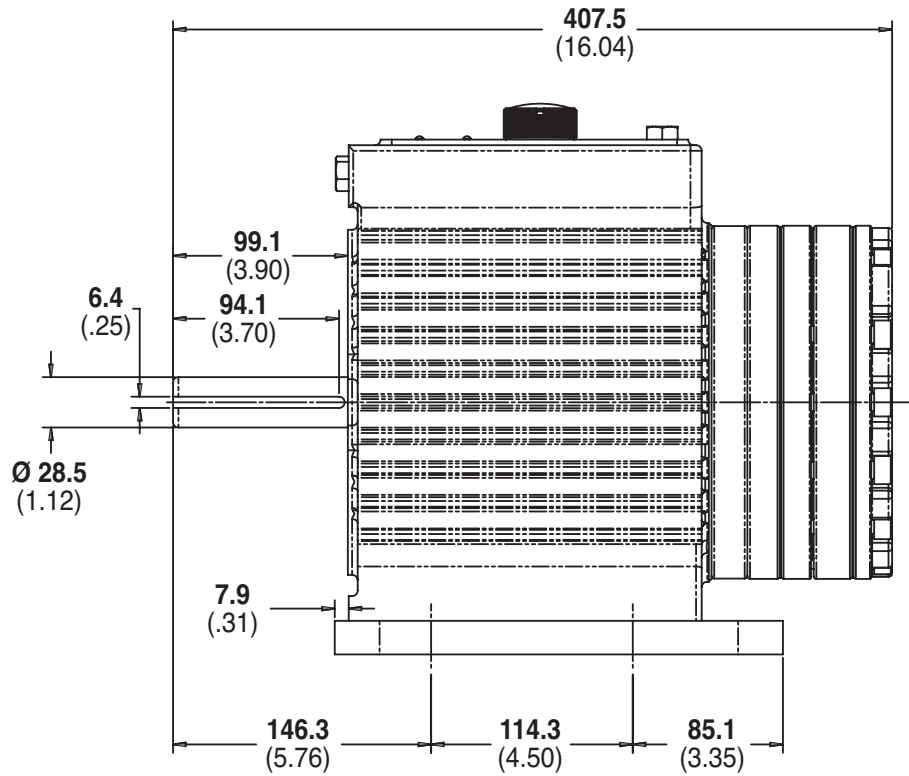

Note: Contact factory for additional drawings of specific models and configurations.

G15 Series Representative Drawings

Pump/Motor Adaptor mm (Inches)

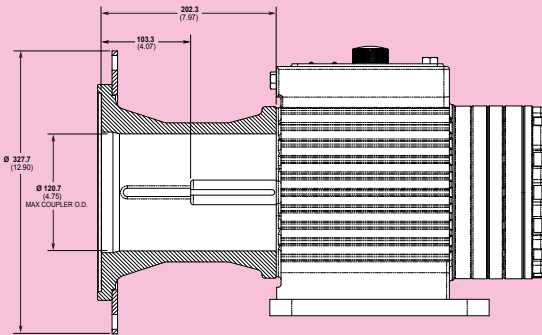

Part Number: A01-041-1201

Must be ordered separately for use with IEC 132 frame motors, B5 flange.

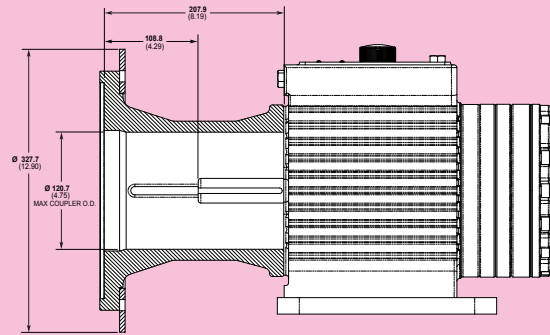

Part Number: A01-041-1205

Must be ordered separately for use with IEC 160 - 180 frame motors, B5 flange.

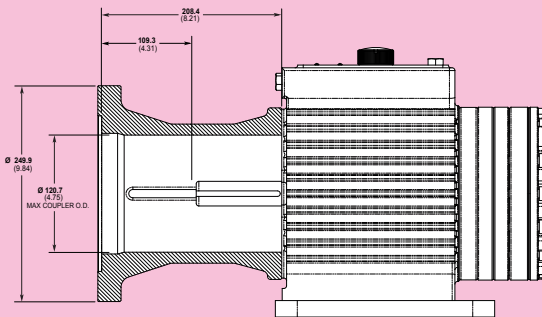

Part Number: A01-041-1203

Must be ordered separately for use with IEC 160 frame motors, B14 flange.

NEMA adaptors available - consult factory.

Valve Selection

A Hydra-Cell G15 Series pumping system uses a C62 Pressure Regulating Valve.



IEC Baseplates

Complete assembly for G15 models (excluding pump and motor) for IEC 132, 160 and 180 frame motors in 304 Stainless Steel.



G15 Series **How to Order**

Ordering Information

1	2	3	4	5	6	7	8	9	10	11	12
---	---	---	---	---	---	---	---	---	----	----	----

A complete G15 Series Model Number contains 12 digits including 9 customer-specified design and materials options, for example: G15XABTHFECG.

Digit	Order Code	Description
1-3	G15	Pump Configuration Shaft-driven (BSPT Ports) *Pump/motor adaptors ordered separately. See previous page.
4	X E	Hydraulic End Cam Max 48.0 l/min (12.7 gpm) @ 1450 rpm Max 43.5 l/min (11.5 gpm) @ 1450 rpm
5	D A	Pump Head Version BSPT Ports ATEX (Note: ATEX 94/9/EC Certified, Category 2, Zone 1. Includes certificate and oil level monitor.)
6	B G S	Pump Head Material Brass Duplex Alloy 2205 316L Stainless Steel
7	G T	Diaphragm & O-ring Material FKM Buna-N
8	D H N	Valve Seat Material Tungsten Carbide 17-4 Stainless Steel Nitronic 50
9	D F N	Valve Material Tungsten Carbide 17-4 Stainless Steel Nitronic 50
10	E H T	Valve Springs Elgiloy (Exceeds SST grade 316L) 17-7 Stainless Steel Hastelloy C
11	C H M P Y	Valve Spring Retainers Celcon 17-7 Stainless Steel PVDF Polypropylene Nylon (Zytel)

Digit	Order Code	Description
12	A B E G H	Hydra-Oil 10W30 standard-duty oil 40-wt for continuous-duty (use with 316L SST pump head - standard) Food-contact oil 5W30 cold-temp severe-duty synthetic oil 15W50 high-temp severe-duty synthetic oil

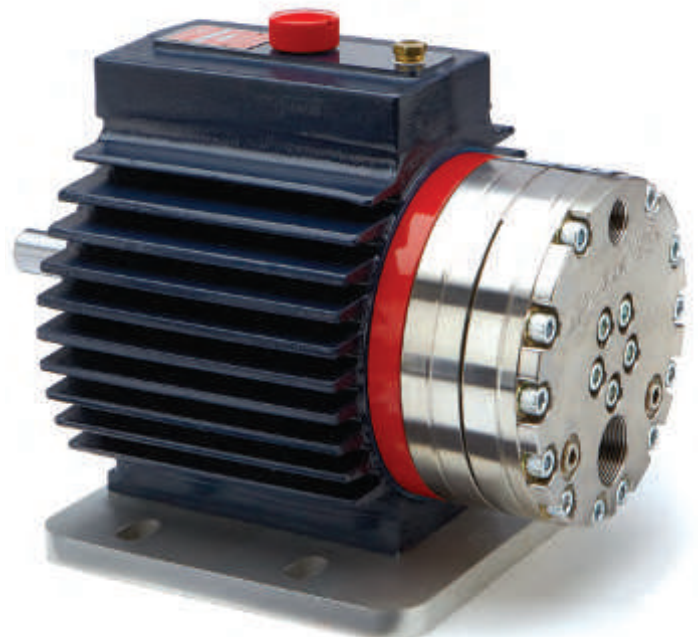



WANNER ENGINEERING - WORLD HEADQUARTERS & MANUFACTURING
Minneapolis USA
t: (612) 332-5681
e: sales@wannereng.com

WANNER PUMPS
Kowloon HONG KONG
t: +852 3428 6534
e: sales@wannerpumps.com

WANNER INTERNATIONAL
Hampshire UK
t: +44 (0) 1252 816847
e: sales@wannerint.com

WANNER ENGINEERING
Latin American Office
t: +55 (11) 4081-7098
e: sales@wannereng.com

WANNER PUMPS
Shanghai CHINA
t: +86-21-6876 3700
e: sales@wannerpumps.com