

## SENSiQ™ Elastomer Mount (SEM) Elastomer Mount for SENSiQ™ RTN/RTB 0.25 t ... 470 t Load Cell



- Self-centering
- Cushions dynamic loads
- Stable to shear forces
- Simple, robust and flat construction
- High resistance to environmental conditions and chemicals
- Easy to assemble
- Maintenance-free

### Application

For technical measurements the elastomer bearing provides ideal load application to Schenck Process ring torsion load cells.

It is used for all industrial scales such as e.g. bin weighers, roller table scales, crane scales and road weighbridges.

### Construction

The Elastomer Mount consists of the pressure piece for load application, the elastomer for self-centering and the base plate for dissipating the load into the supporting construction.

The lateral play must be limited depending on the application. Similarly a lifting restraint should be fitted to prevent lifting.

### Function

The weight to be measured is applied to the load cell by means of the pressure piece. The design means that the vertical deflection is extremely small and proportional to the load.

Any lateral forces deform the elastomer in a parallel manner. It automatically will center itself as soon as the lateral force ceases.

A load distribution plate above the pressure piece may be necessary depending on the permissible bearing pressure of the load pick-up. This should always be checked for a transition from steel to concrete.

### Important Notice:

A non-reproducible application of force into the load cell may occur when lifting and re-applying the load application elements, causing measuring errors in the scales overall. The Elastomer Mount therefore may never completely be unloaded. The minimum pre-load should be large enough so that there always is a non-positive connection between the load cell and the pressure piece or base plate.

### Elastomer Mount SEM 0.25 t ... 0.50 t for RTB load cells

- the elastomer is located above the pressure piece
- the pressure piece is bolted or pinned to the connecting structure by means of two straps on the side
- height compensation (max. 5 mm) is performed using shims
- the bearing is aligned using by moving the base plate that is secured using the fixing pieces to be pinned or bolted on.

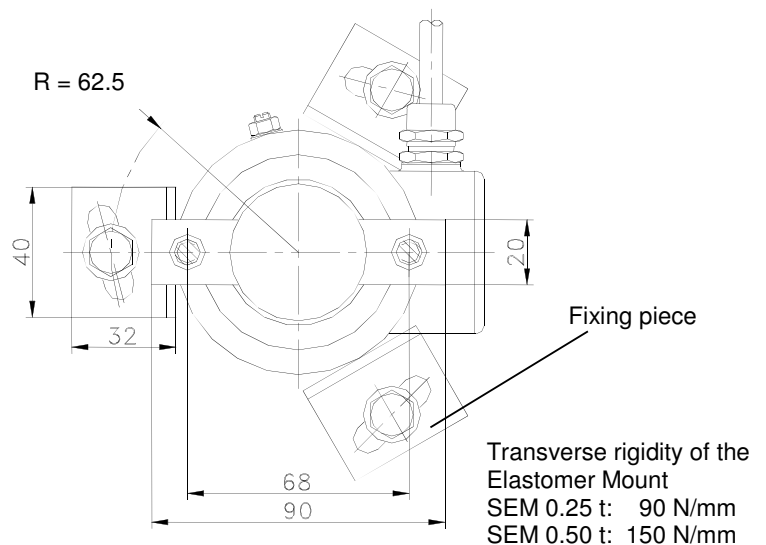
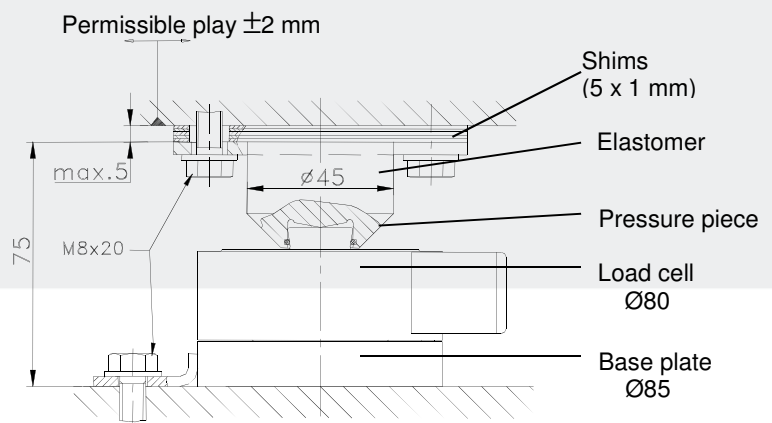

### Elastomer Mount SEM 1 t ... 4.7 t for RTN load cells

- the elastomer is located above the pressure piece
- the pressure piece is bolted or pinned to the connecting structure by means of two straps on the side
- height compensation (max. 5 mm) is performed using shims
- the SEM is aligned using by moving the base plate that is secured using the fixing pieces to be pinned or bolted on
- it also may be anchored using a centering bolt.
- The head and base of the Elastomer Mount can directly be connected to the connecting structure by bolting them to it. By using the optionale weld-on plates, there is no need to drill and thread the connecting structure. The weld-on plates are welded onto the construction after the load receptor has been aligned. They then hold the bearing with their tap holes. The weld-on plates for the load range 1 t ... 4.7 t can be used above and/or below the SEM. The additional height will be 15 mm each.

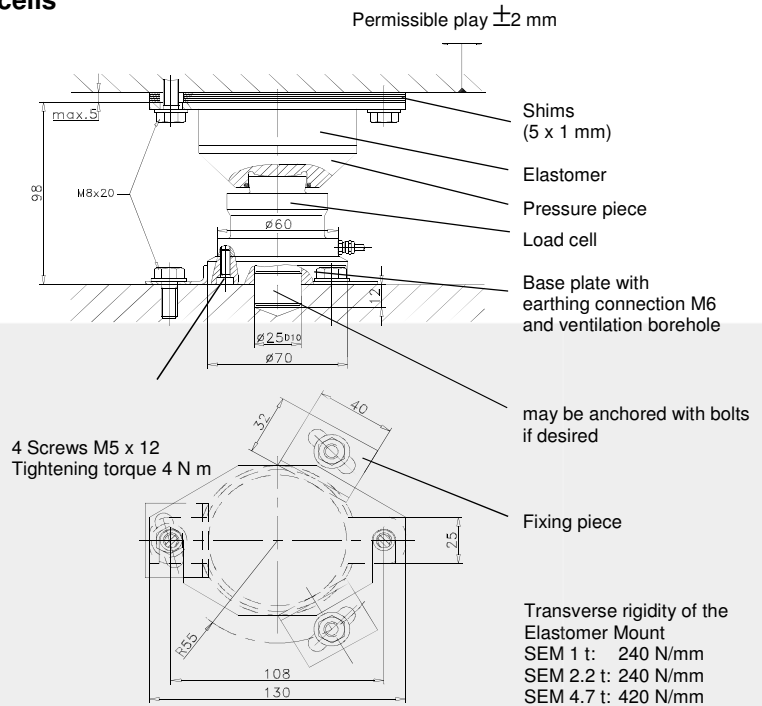

### Elastomer Mount SEM 10 t ... 470 t for RTN load cells

- the elastomer is located beneath the load cell
- the pressure piece is secured using a centering piece that is bolted or pinned to the connecting structure
- height compensation (max. 5 mm) is performed using shims
- the SEM is aligned using by moving the elastomer that is secured using straps to be pinned or bolted on
- the head and base of the Elastomer Mount can directly be connected to the connecting structure by bolting them to it. By using the optionale weld-on plates, there is no need to drill and thread the connecting structure. The Elastomer Mount is welded directly to the lower side of the bearing. Additional construction height of the weld-on plate:
  - SEM 10 t ... 22 t: 20 mm
  - SEM 33 t: 25 mm
  - Other nominal loads are available on request

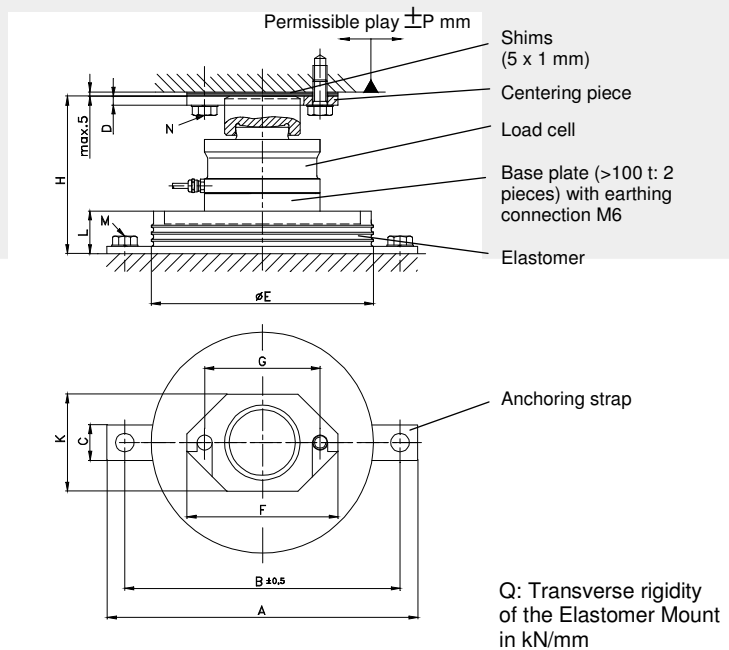

Type SEM	Dimensions (mm)													
	A	B	C	D	E	S	G	H	K	L	M	N	P	Q
10-22	190	170	25	6	135	90	68	130	60	41	M10x25	M10x25	6	1.4
33	280	250	30	6	175	120	90	168	80	56	M12x25	M12x25	6	1.7
47	350	310	40	10	250	170	130	198	110	63	M16x30	M16x30	6	3.1
68	350	310	40	10	250	170	130	220	110	63	M16x30	M16x30	6	3.1
100	400	360	40	10	300	180	140	239	130	68	M16x30	M16x30	6	4.3
150	510	460	50	10	400	180	140	320	130	81	M20x45	M16x30	8	6.8
220	560	510	50	12	450	260	200	373	180	81	M20x45	M20x45	8	8.7
330	680	620	60	12	550	260	200	427	180	96	M24x40	M24x40	10	7.3
470	780	720	60	12	650	320	240	520	220	115	M24x40	M24x40	13	7.7

## Technical Data

Type	SEM		SEM		SEM	
Nominal load	0.25 t ... 0.50 t		1 t ... 100 t		150 t ... 470 t	
Weight (including load cell)	SEM 0.25 ... 0.50 2.8 kg		SEM 1 ... 4.7 2.9 kg	SEM 10 ... 22 5.3 kg	SEM 150 120 kg	SEM 220 170 kg
			SEM 33 14 kg	SEM 47 26 kg	SEM 330 250 kg	SEM 470 410 kg
			SEM 68 29 kg	SEM 100 43 kg		
	<b>Standard SEM</b>			<b>SEM for Extended Temperature Range</b>		
<b>Materials</b>	SEM 0.25 t ... 4.7 t		SEM 10 t ... 470 t		SEM 0.25 t ... 4.7 t	
	SEM 10 t ... 470 t		SEM 0.25 t ... 4.7 t		SEM 10 t ... 470 t	
Metal parts	entirely of stainless steel		S235 galvanized		entirely of stainless steel	
	S235 galvanized		S355 galvanized		S355 galvanized	
Elastomer	Neoprene (CR)		Neoprene (CR)		Silicone (VMQ)	
	Neoprene (CR)		Silicone (VMQ)		Silicone (VMQ)	
Nominal temperature (restricted by the load cell)	-10 °C ... +40 °C			-10 °C ... +40 °C		
Service temperature (restricted by the load cell)	-30 °C ... +100 °C			-50 °C ... +110 °C		
Compression stroke	approx. ≤ 0.8 mm at nominal load					
max. permissible inclination of the substructure	0.2°					
max. permissible angle between upper and lower connecting structure	0.6°					

Standard SEM				SEM with silicone (VMQ)			
Model/Order numbers				Model/Order numbers			
<b>SEM 0.25</b>	V041386.B01	<b>SEM 33</b>	D 725575.02	<b>SEM 1/2.2</b>	D 726185.11	<b>SEM 100</b>	D 725575.25
<b>SEM 0.50</b>	V041387.B01	<b>SEM 47</b>	D 725575.03	<b>SEM 4.7</b>	D 726185.12	<b>SEM 150</b>	D 726186.11
<b>SEM 1</b>	D 726185.01	<b>SEM 68</b>	D 725575.04	<b>SEM 10 ... 22</b>	D 725575.20	<b>SEM 220</b>	D 726186.12
<b>SEM 2.2</b>	D 726185.01	<b>SEM 100</b>	D 725575.05	<b>SEM 10 ... 22</b>	D 725575.21*)	<b>SEM 330</b>	D 726186.13
<b>SEM 4.7</b>	D 726185.02	<b>SEM 150</b>	D 726186.01	<b>SEM 33</b>	D 725575.22	<b>SEM 470</b>	D 726186.14
<b>SEM 10 ... 22</b>	D 725575.10	<b>SEM 220</b>	D 726186.02	<b>SEM 47</b>	D 725575.23		
<b>SEM 10 ... 22</b>	D 725575.11*)	<b>SEM 330</b>	D 726186.03	<b>SEM 68</b>	D 725575.24		
		<b>SEM 470</b>	D 726186.04				

\*) Metal parts made of stainless steel

**Attention:** SEM may only be used in the explosion-protected area only in Zone 2/21/22 without restriction. For zone 1 the declaration of conformity must be observed.

**(Load cell not included in delivery)**

Optional weld-on plates available, refer to data sheet BV-D2228  
Other nominal loads and materials available on request.

Also available:

- SENSiQ™ Secure Mount 0.25 t ... 470 t (BV-D2083)
- SENSiQ™ Secure Mount PLUS 10 t ... 330 t (BV-D2444)
- SENSiQ™ Pendulum Mount 1 t ... 100 t (BV-D2025)
- SENSiQ™ Fixed Mount 1 t ... 470 t (BV-D2182)
- SENSiQ™ Fixed Mount PLUS 10 t ... 330 t (BV-D2442)

### Schenck Process Europe GmbH

Pallaswiesenstr. 100  
64293 Darmstadt, Germany  
Phone: +49 6151 1531-0  
Fax: +49 6151 1531-66  
sales@schenckprocess.com  
www.schenckprocess.com