

# **EL320.240.36-HB SPI**

## **Series (5.7")**

### **Operation Manual**

**Table of contents:**

1	EL320.240.36-HB SPI Quarter-VGA display .....	3
1.1	Features and benefits .....	3
2	Installation and handling .....	3
2.1	Mounting TFEL displays .....	4
2.2	Cable length .....	4
2.3	Cleaning.....	4
2.4	Avoiding burn-in .....	4
3	Specifications .....	5
3.1	Control basics .....	5
3.2	Power .....	5
3.3	Connector .....	6
3.3.1	Dimming connector J2.....	7
3.4	Interface information .....	8
3.4.1	Initial power-up.....	8
3.4.2	SPI Protocol and timing .....	8
3.5	Dimming .....	8
3.6	Self-test mode .....	8
3.7	Optical .....	9
3.8	Environmental .....	10
3.9	Reliability .....	10
3.10	Safety and EMI performance.....	10
3.11	Optional features .....	10
3.12	Mechanical characteristics .....	11
3.13	Component envelope .....	11
4	Description of warranty .....	14
5	Ordering information .....	15
6	Support and service.....	15
7	RoHS III .....	15

## 1 EL320.240.36-HB SPI Quarter-VGA display

The EL320.240.36-HB SPI thin film electroluminescent (TFEL) display is a high-performance alternative to quarter-VGA LCDs and the ideal solution in demanding applications where superior visual performance and environmental ruggedness are critical. The EL320.240.36-HB SPI utilizes Lumineq<sup>®</sup> Displays' proprietary Integral Contrast Enhancement (ICEBrite™) technology to achieve unparalleled image quality without the use of expensive filters. This small graphics display excels in a wide range of ambient lighting environments while effectively eliminating the blooming common to other high-bright displays.

The display consists of a TFEL glass panel and control electronics assembled into a space-saving, rugged package for easy mounting. The EL320.240.36-HB SPI is easily interfaced using the Serial Peripheral Interface (SPI) bus. Each of the 76,800 pixels is individually addressable to clearly display high information content graphics and text.

The display is available with an optional tempered glass for enhance the display front glass damage resistance, and with ITO glass including a metallized edge to improve the display EMI properties.

### 1.1 Features and benefits

- Excellent visual performance
  - High brightness and contrast
  - Wide viewing angle < 179°
- Rapid display response < 1 ms
- Frame buffer
- Space-efficient mechanical package
- Low EMI emissions
- Extremely rugged and durable
- Reliable, long operating life
- SPI interface

## 2 Installation and handling

Do not drop, bend, or flex the display. Do not allow objects to strike the surface of the display.

**CAUTION:** The display uses CMOS and power MOS-FET devices. These components are electrostatic-sensitive. Unpack, assemble, and examine this assembly in a static-controlled area only. When shipping the displays, use packing materials designed for protection of electrostatic-sensitive components.

## 2.1 Mounting TFEL displays

Properly mounted, TFEL displays can withstand high shock loads as well as severe vibration found in demanding applications. However, the glass panel used in a TFEL display will break if subjected to bending stresses, high impact, or excessive loads.

Avoid bending the display. Stresses are often introduced when a display is mounted into a product. Ideally, the mounting tabs of the display should be the only point of contact with the system. Use a spacer or boss for support; failure to do so will bend the display and cause the glass to break. The instrument enclosure or frame should not flex or distort in such a way that the bending loads might be transferred to the display during use. The EL320.240.36-HB SPI mounting tabs are designed for 3 mm screws. Mounting surfaces should be flat to within  $\pm 0.6$  mm ( $\pm 0.025$ " ). Use all the mounting holes provided. Failure to do so will impair the shock and vibration resistance of the final installation.

Additional ITO glass can be connected to the equipment enclosure via metallized ITO glass edge by using a conductive elastomer material.

**CAUTION:** To prevent injury in the event of a glass breakage, a protective overlay should be used on the viewer side of the display.

**WARNING:** These products generate voltages capable of causing personal injury (high voltage up to 235 V<sub>AC</sub>). Do not touch the display electronics during operation.

## 2.2 Cable length

A maximum cable length of 0.6 m (24 in.) is recommended. Longer cables may cause data transfer problems between the data transmitted and the display input connector. Excessive cable lengths can pick up unwanted EMI.

## 2.3 Cleaning

As with any glass or coated surface, care should be taken to minimize scratching. Clean the display glass with mild, water-based detergents only. Apply the cleaner sparingly to a soft cloth, and then wipe the display. Disposable cleaning cloths are recommended to minimize the risk of inadvertently scratching the display with particles embedded in a re-used cloth. Particular care should be taken when cleaning displays with anti-glare and anti-reflective films.

## 2.4 Avoiding burn-in

As with other light-emitting displays, use a screensaver or image inversion to avoid causing burn-in on the display. Displaying fixed patterns on the screen can cause burn-in where luminance variations can be noticed.

### 3 Specifications

Performance characteristics are guaranteed when measured at 25 °C with rated input voltage unless otherwise specified.

#### 3.1 Control basics

The TFEL panel is a matrix structure with column and row electrodes arranged in an X-Y formation. Light is emitted when an AC voltage of sufficient amplitude is applied at a row-column intersection. The display operation is based on the symmetric, line-at-a-time data addressing scheme.

#### 3.2 Power

The supply voltages are shown in Table 1. All internal high voltages are generated from the display supply voltage ( $V_H$ ). The logic supply voltage ( $V_L$ ) should be present whenever video input signals or  $V_H$  is applied. The minimum and maximum specifications in this manual should be met, without exception, to ensure the long-term reliability of the display. Beneq does not recommend operation of the display outside these specifications.

**Table 1. DC input voltage requirements**

Parameter	Symbol	Min	Typ	Max	Absolute Max
Logic supply voltage	$V_L$	4.75 V	5 V	5.25 V	6 V
Logic supply current at +5 V	$I_L$			0.10 A	
Display supply voltage	$V_H$	8 V	12 V	18 V	19 V
Supply current at +12 V	$I_H$		0.4A	0.9 A	
Power consumption @ maximum frame rate			5.5 W	11 W	
Power consumption @ 120 Hz			3.5 W		

**CAUTION:** Absolute maximum ratings are those values beyond which damage to the device may occur.

**Table 2. SPI input requirements**

Description	Min	Max	Units	Notes
Absolute Input Voltage Range	-0.3	5.5	V	$V_L = 5.0$ V
SPI Logic high voltage	2.2	5.0	V	All input thresholds are TTL
SPI Logic low voltage	0	0.8	V	
Input capacitance	-	15	pF	

There is no overcurrent protection on either the  $V_H$  or  $V_L$  inputs to protect against catastrophic faults. Beneq recommends the use of a series fuse on the 12-volt supply ( $V_H$ ). A general guideline is to rate the fuse at 1.8 to 2 times the display maximum current rating.

### 3.3 Connector

The display uses the Samtec EHT-110-01-S-D or equivalent locking connector. The mating connector is in the Samtec TCSD family of cable strips. The proper connector, user-specified cable length and connector configuration is supplied as a single unit. Consult your Samtec representative for the cable/connector options. Compatibility with non-Samtec equivalents should be verified before use.

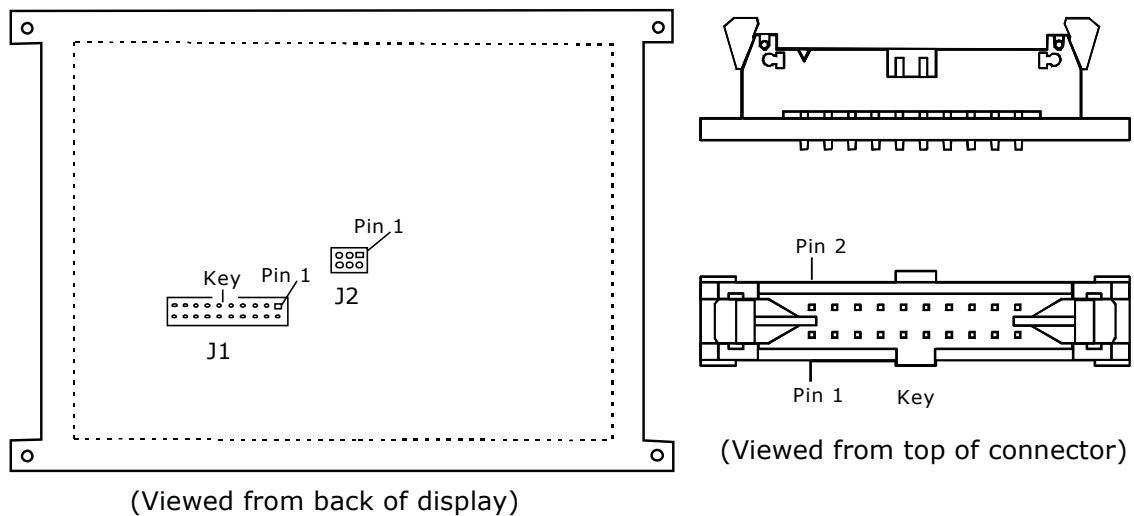

**Figure 1. Data/power connector**

**Table 3. J1 Connector pinouts**

Pin	Signal	Description	Pin	Signal	Description
1	$V_H$	+12 VDC Power	2	$V_H$	+12 VDC Power
3	Self-test	Self-test Input (1)	4	Reserved	Do not connect
5	$V_L$	+5 VDC Power	6	GND	Ground
7	SS	Slave Select	8	GND	Ground
9	Reserved	Do not connect	10	GND	Ground
11	SCLK	Clock from master	12	GND	Ground
13	MOSI	Master Out Slave In	14	GND	Ground
15	Reserved	Do not connect	16	GND	Ground
17	Reserved	Do not connect	18	GND	Ground
19	Reserved	Do not connect	20	GND	Ground

Note: 1) Connect pin 3 to ground for normal display operation.

### 3.3.1 Dimming connector J2

The J2 analog dimming connector is a Berg six-pin, dual in-line header, part number 98424-G52-06LF. The mating connector is the Berg 89947-106LF (IDC) or a combination of the Berg 77138-101LF (discrete crimp-to-wire) and the Berg 903111-006LF (housing). Refer to "Dimming" on page 9 for more information.

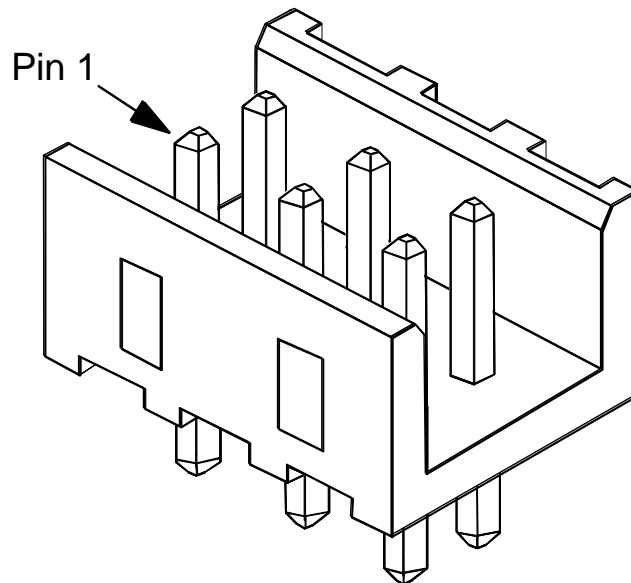

The pin assignments are:

Pin	Symbol	Description
1	LUMA	Analog dimming
2	GND	Ground
3	Reserved	Reserved, do not connect
4	Reserved	Reserved, do not connect
5	GND	Ground
6	Reserved	Reserved, do not connect

## 3.4 Interface information

Beneq EL320.240.36-HB SPI incorporates a common SPI interfaces. This interface is supported by a variety of off-the-shelf chip sets and embedded boards. Designers should select the chip set or embedded board that best suits their architecture.

### 3.4.1 Initial power-up

On initial power-up, the display registers are reset to their default values and all pixels are blanked. At this time all registers must be programmed for normal operations.

### 3.4.2 SPI Protocol and timing

See Operation Manual Addendum:

**Addendum for Operation Manuals**  
**SPI Protocol**  
**Matrix SPI Displays**  
**Document number: ED001649.**

SPI Protocol MISO-signal is not in use.

## 3.5 Dimming

Analog dimming using the J2 dimming. The display analog dimming range is from 100% to approximately 5% of the full brightness. To perform analog dimming, connect a 50 k $\Omega$  variable resistor between LUMA and GND.

## 3.6 Self-test mode

The display incorporates a self-test mode composed of two patterns displayed at maximum frame rate for approximately 30 seconds each, and then repeated. The patterns are as follows: 50/50 Checkerboard and Full On. The self-test mode is entered by leaving pin 3 on J1 unconnected or pulled high. This pin has an internal pull-up. Connect pin 3 on J1 to ground for normal display operation.



### 3.7 Optical

**Table 4. Optical characteristics**

<b>Luminance</b>		
L <sub>on</sub> (areal), min	120 cd/m <sup>2</sup> (HB SPI) 115 cd/m <sup>2</sup> (HB TI SPI M)	Screen center, maximum frame rate
L <sub>on</sub> (areal), typ	150 cd/m <sup>2</sup> (HB SPI) 145 cd/m <sup>2</sup> (HB TI SPI M)	Screen center, maximum frame rate
L <sub>off</sub> (areal), max	0.3 cd/m <sup>2</sup>	5 points: center plus four corners measured 1.0 ±0.25" from adjacent bezel edges, @ 120 Hz
<b>Non-uniformity</b>		
All pixels fully lit	35 %	Maximum difference two of five points, using the formula: BNU %=[1- (min_lum/max_lum)] x 100 %
<b>Luminance variation (temperature)</b>		
Maximum	±25 %	Across the operating temperature range
<b>Luminance variation (time)</b>		
Maximum	< 20 %	10,000 hours at 25 °C ambient
<b>Viewing angle</b>		
Minimum	> 179° in all directions; no contrast or luminance change	
<b>Contrast ratio (typical)</b>		
Typical	90:1	@ 500 lux ambient, maximum frame rate
	8:1	@ 10,000 lux ambient, maximum frame rate

### 3.8 Environmental

**Table 5. Environmental characteristics**

<b>Temperature</b>	
Operating	-40 °C to +85 °C
Operating Survival	-50 °C to +95 °C
Storage	-50 °C to +105 °C
<b>Humidity</b>	
Non-condensing, operating	93% RH max at +40 °C, per IEC 60068-2-78
Condensing, non-operating	95% RH max at +55 °C, per IEC 60068-2-30
<b>Altitude</b>	
Operating/non-operating	0 to 18 km (58k ft), per IEC60068-2-13
<b>Vibration</b>	
Random Operating/non-operating	0.05 g <sup>2</sup> /Hz, ASD level, 5-500 Hz per, IEC 60068-2-64 test Fh.
<b>Shock</b>	
Operating/non-operating	100 g, 6 ms, half sine wave per IEC 60068-2-27, test Ea.

### 3.9 Reliability

The display MTBF is to be greater than 50,000 hours at 120 Hz with a 90 % confidence level at 25 °C.

### 3.10 Safety and EMI performance

The display will not inhibit the end product from obtaining these certifications: IEC 950, IEC 601-1-1, UL2601, CSA 22.2 #601-M89, FCC Docket, Part 15, Subpart J, Class B; CISPR22, Class B; and VDE 871/VFG243 Class B.

### 3.11 Optional features

Anti-reflective and anti-glare filters are available as an option.

### 3.12 Mechanical characteristics

**Table 6. Mechanical characteristics**

<b>Display external dimensions</b>		
millimeters (inches)	width	148.1 (5.83)
	height	104.7 (4.12)
With component envelope	depth	20 (0.8)
<b>Weight</b>		HB SPI: 180 g ± 10 g (6.35 oz ± 0.35 oz) HB TI SPI M: 225 g ± 10 g (7.94 oz ± 0.35 oz)
<b>Fill factor</b>		74 %
<b>Display active area</b>		
millimeters (inches)	width	115.1 (4.5)
	height	86.3 (3.40)
<b>Pixel size</b>		
	width	0.31 (0.012)
	height	0.31 (0.012)
<b>Pixel pitch</b>		
millimeters (inches)	Width	0.36 (0.014)
	Height	0.36 (0.014)

### 3.13 Component envelope

The component envelope shown in 4 illustrates the distance the components extend behind the display. Tall components do not necessarily fill this area. Beneq reserves the right to relocate components within the constraints of the component envelope without prior customer notification. For this reason, Beneq advises users to design enclosure components to be outside the component envelope.

Device designers will need to consider their specific system requirements to determine the spacing necessary to maintain the specified ambient temperature.

Air flow and surrounding component materials will affect the depth of the air gap.

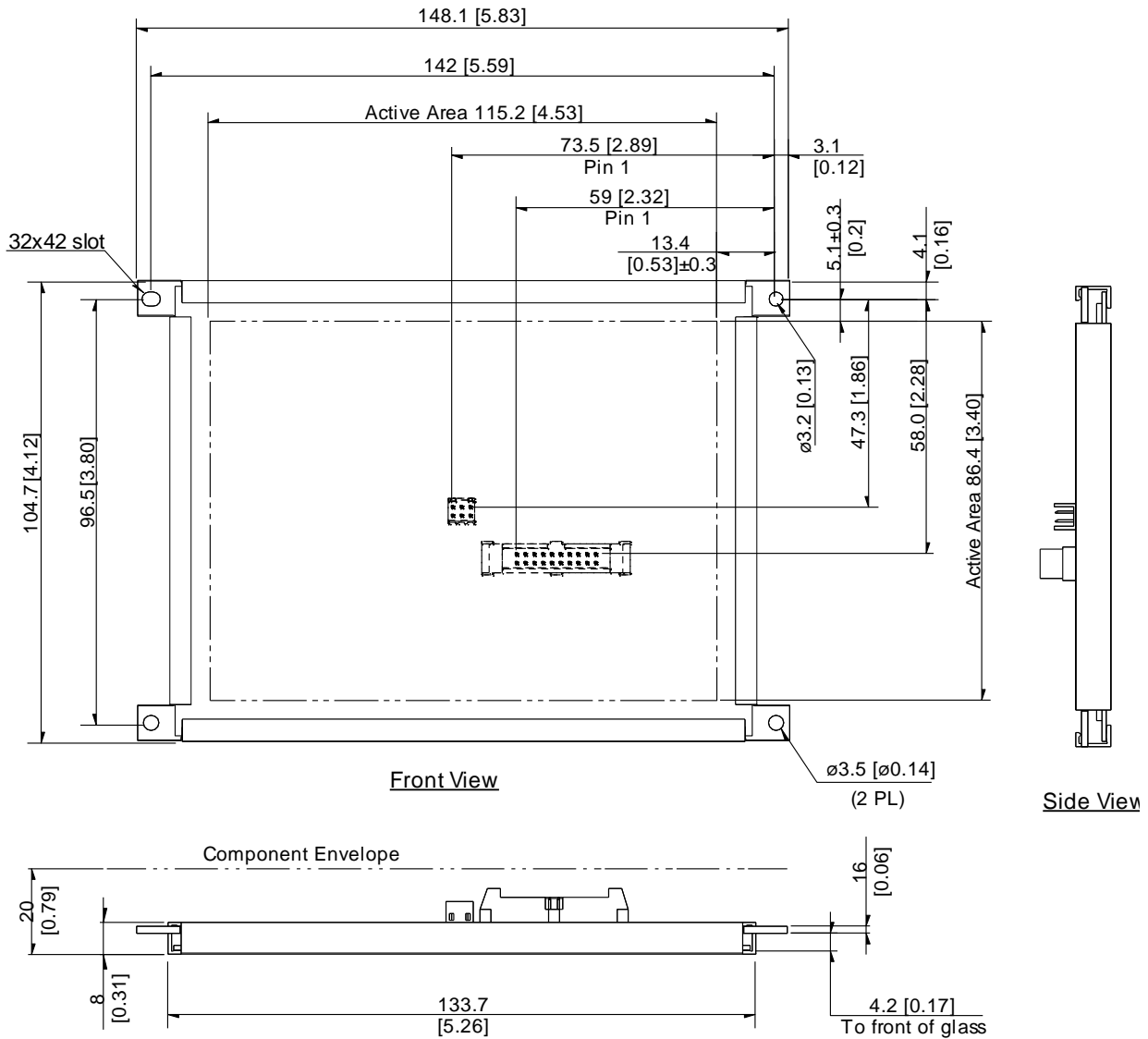

**Top View**  
 Dimensions are in millimeters; inches in brackets.  
 Tolerances unless specified  
 .x ±0.50 [0.02]  
 .xx ±0.25 [0.01]

**Figure 4. Display dimensions**

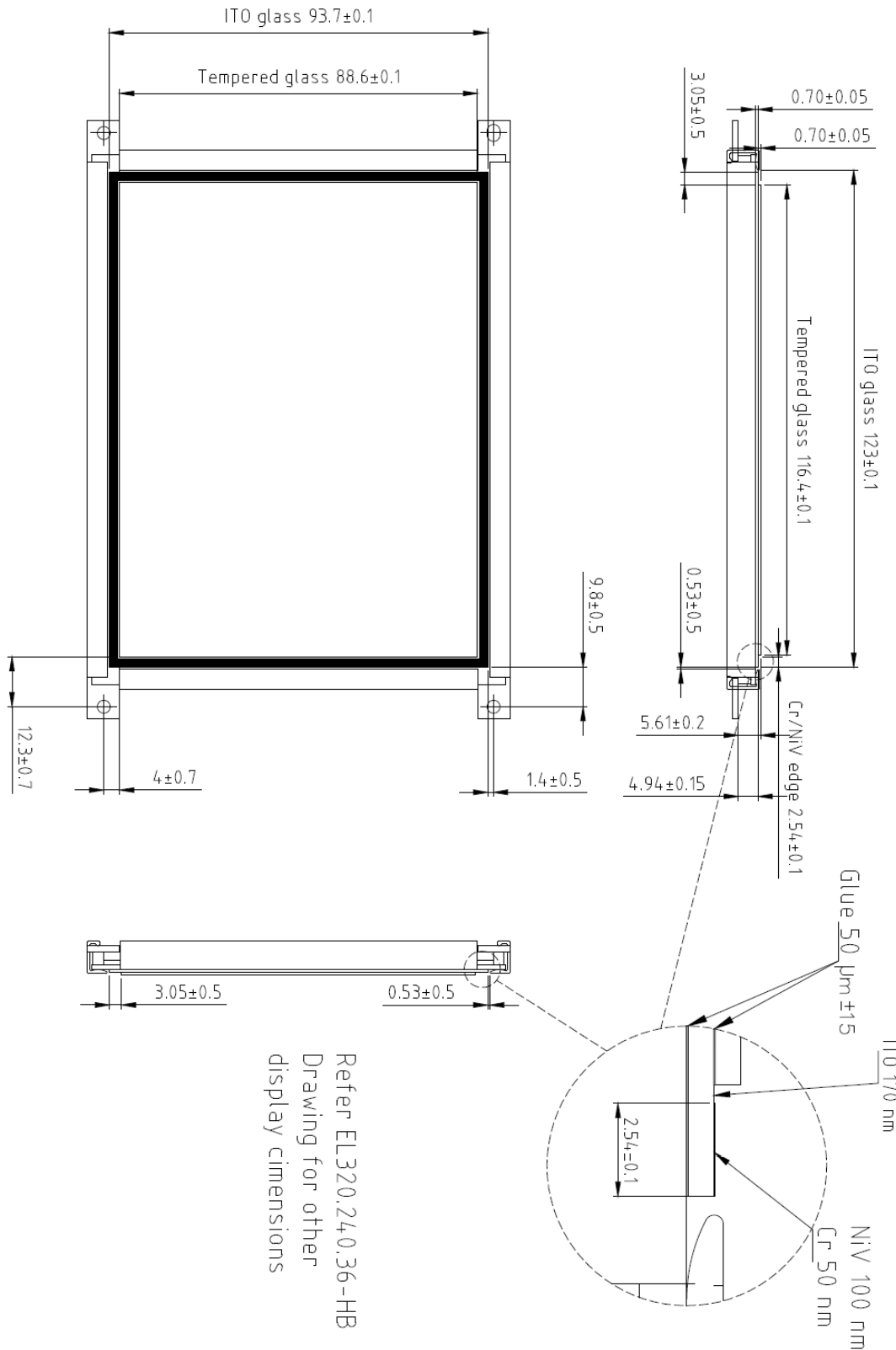

Figure 5. EL320.240.36-HB TI SPI M CC Additional drawing

## 4 Description of warranty

Seller warrants that the Goods will conform to published specifications and be free from defects in material during warranty time from delivery. To the extent that goods incorporate third-party-owned software, seller shall pass on seller's licensor's warranty to buyer subject to the terms and conditions of seller's license.

Warranty repairs shall be warranted for the remainder of the original warranty period. Buyer shall report defect claims in writing to seller immediately upon discovery, and in any event, within the warranty period. Buyer must return goods to seller within 30 days of seller's receipt of a warranty claim notice and only after receiving seller's return goods authorization. Seller shall, at its sole option, repair or replace the goods.

If goods were repaired, altered or modified by persons other than seller, this warranty is void. Conditions resulting from normal wear and tear and buyer's failure to properly store, install, operate, handle or maintain the goods are not within this warranty. Repair or replacement of goods is seller's sole obligation and buyer's exclusive remedy for all claims of defects. If that remedy is adjudicated insufficient, Seller shall refund buyer's paid price for the goods and have no other liability to buyer.

All warranty repairs must be performed at seller's authorized service center using parts approved by seller. Buyer shall pay costs of sending goods to seller on a warranty claim and seller shall pay costs of returning goods to buyer. The turnaround time on repairs will usually be 30 working days or less. Seller accepts no added liability for additional days for repair or replacement.

If seller offers technical support relating to the goods, such support shall neither modify the warranty nor create an obligation of seller. Buyer is not relying on seller's skill or judgment to select goods for buyer's purposes. Seller's software, if included with goods, is sold as is, and this warranty is inapplicable to such software.

**SELLER DISCLAIMS ALL OTHER WARRANTIES, EXPRESS OR IMPLIED, INCLUDING BUT NOT LIMITED TO, IMPLIED WARRANTIES OF MERCHANTABILITY AND FITNESS FOR A PARTICULAR PURPOSE.**

## 5 Ordering information

Product	Part Number	Description
EL320.240.36-HB SPI	EL00101700	5.6" (142 mm) diagonal, quarter VGA (QVGA) high-bright display, -40 °C to +85 °C operating temperature, SPI interface
EL320.240.36-HB SPI CC	EL00101800	EL320.240.36-HB SPI with conformal coating added to the circuit board
EL320.240.36-HB TI SPI M CC	EL00101900	EL320.240.36-HB SPI CC with ITO and tempered glass.

Design and specifications are subject to change without notice.

Beneq continues to provide optional, and in many cases custom, features to address the specific customer requirements. Consult Beneq Sales for pricing, lead time and minimum quantity requirements.

## 6 Support and service

Beneq is a Finnish company based in Espoo, Finland, with a world-wide sales distribution network. Full application engineering support and service are available to make the integration of Lumineq displays as simple and quick as possible for our customers.

**RMA Procedure:** For a Returned Material Authorization number, please contact Beneq Oy by email ([rma.lumineq@beneq.com](mailto:rma.lumineq@beneq.com)) with the model number(s), serial number(s) and brief description of the problem. When returning goods for repair, please include a brief description of the problem, and mark the outside of the shipping container with the RMA number.

## 7 RoHS III

Lumineq EL320.340.36-HB SPI Series displays are RoHS3 (Restrictions of Hazardous Substances in Electronic/Electrical Equipment) compliant and meet the requirements defined under European Union Directive (2015/863), that restrict the use of various hazardous substances in electronic equipment

This document is compiled and kept up-to-date as conscientiously as possible. Beneq cannot, however, guarantee that the data are free of errors, accurate or complete and, therefore, assumes no liability for loss or damage of any kind incurred directly or indirectly through the use of this document. The information in this document is subject to change without notice. All texts, pictures, graphics and any other contents of this document and their layout are protected by copyright and other protective laws. The aforementioned contents may not be duplicated, modified or used in other electronic or printed publications without the prior consent of Beneq. Unless otherwise stated, all trademarks are protected under trademark laws, especially the Beneq trademarks, logos, emblems and nameplates. The patents and trademarks presented in this document are the intellectual property of Beneq Oy. Beneq and Lumineq are registered trademarks of Beneq Oy. ICEBrite is a trademark of Beneq O