

# Evolving and Optimizing Security and Surveillance Systems

---

Security and surveillance cameras are all around us. Look around and you will find them in virtually every place you go. Some common applications include:

- In retail stores to monitor customer activity and protect against theft
- In small businesses and large corporations for identity verification and physical security both indoors and outdoors
- Throughout intelligent transportation systems for traffic monitoring and emergency dispatch
- On the streets for law enforcement and public safety

As the demand for security and surveillance grows, the advancements in technology have made it possible to implement higher quality devices more easily and in more locations.

Unfortunately, one common area that is often overlooked is the quality of the cabling infrastructure used to transport video images from the cameras to the monitor or storage device. Designing your video network around coaxial, unshielded twisted pair (UTP) or fiber optic cable will have a tremendous impact on the flexibility, as well as the quality, bandwidth and distance capabilities of your video security and surveillance system.

## Typical Video Security Systems

Video surveillance systems can be analog or IP-based and include common components such as cameras, cable infrastructure, monitors and a means of recording the video for future use and playback. Each type of network has its own set of challenges.

### Analog Video Systems

Closed-circuit television (CCTV) systems have been in use for many years and comprise the vast majority of existing video security systems. In a typical CCTV system, analog cameras are connected via coaxial cabling back to a central management room where the coax is connected to a monitor(s) and a video cassette recorder (VCR) or digital video recorder (DVR). An additional component, called a controller, is used if the cameras have pan-tilt-zoom (PTZ) capability and is generally centrally located. All components are dedicated to this CCTV system and the system is “closed” to external access.

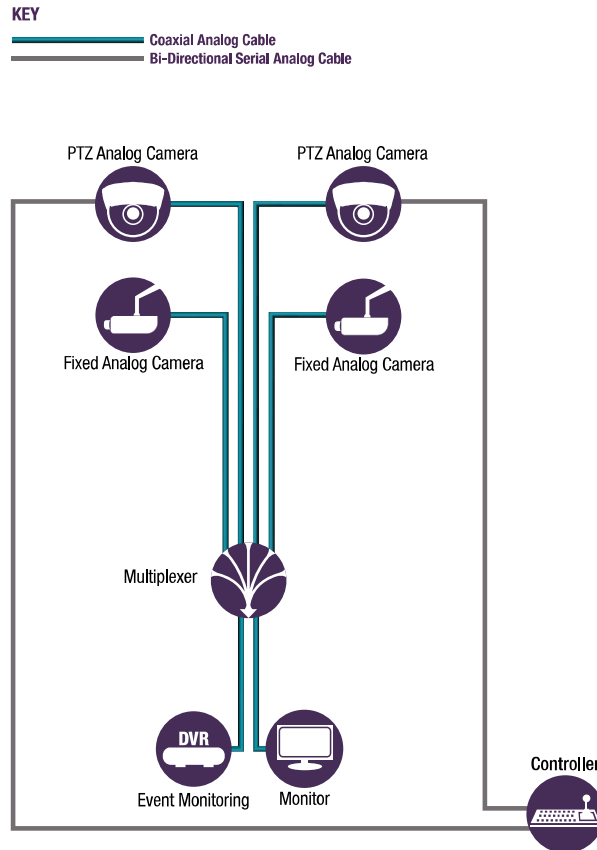

Fig. 1: Basic Analog Video Security System with Fixed and PTZ Cameras

While CCTV systems are simple to install and generally perceived as inexpensive, there are several inherent limitations to these systems. For instance, the number of channels available is limited. The location of cameras is also restricted by the cable distance limitation and inferior transmission quality of the coax or unshielded twisted pair (UTP) cable. In addition, monitoring of the system must be done locally due to these quality and distance barriers. Expanding the surveillance area of the system requires purchasing more cameras, more VCR/DVRs and more monitors, quickly eliminating the initial cost savings of a CCTV system.

However Transition Networks can help protect your initial investment in analog CCTV systems by implementing cost-effective upgrades to IP Video with the addition of fiber into the video security and surveillance system.

### IP Video Systems

IP-based systems have more recently been implemented for security and surveillance. In a typical IP video system, network (IP) cameras are connected directly to the Local Area Network (LAN) and transport digital video across the IP network via UTP cabling and switches, recording video to any PC or server on the network. Since the cameras are IP addressable, they are able to be accessed from anywhere in the world, provided the user has the sufficient network access and security privileges.

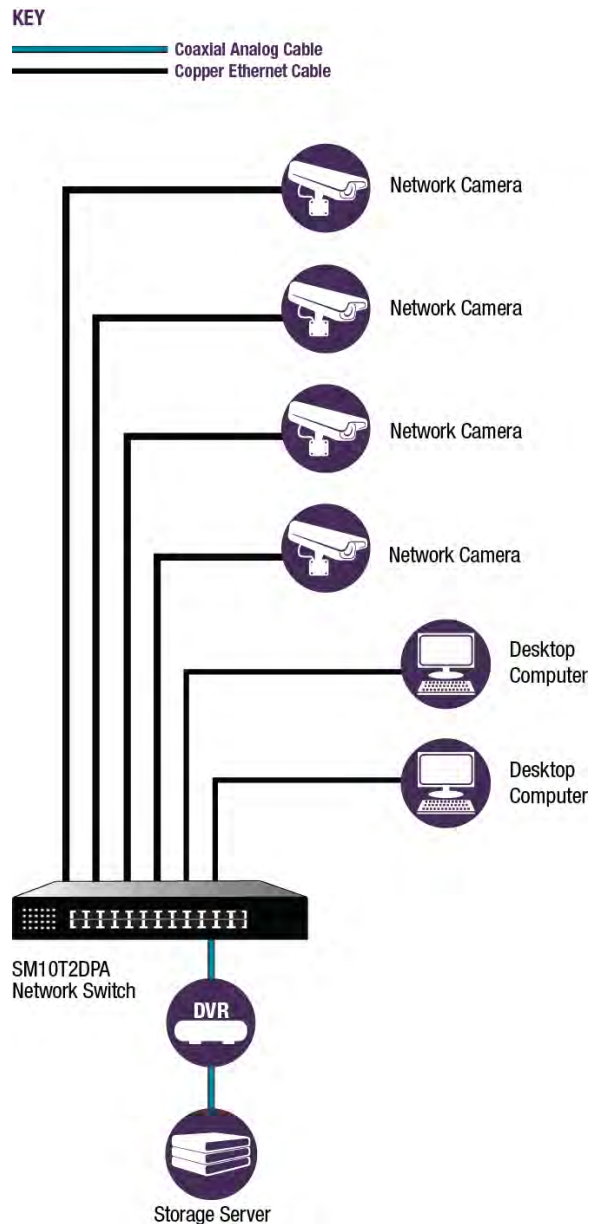

Fig. 2: Basic IP Video Security System

Although IP cameras are initially more costly than analog CCTV cameras, the higher resolution provides a better picture quality, which is often required to achieve the goals originally intended by installing a security and surveillance system. The higher quality of IP cameras also allows them to cover a greater area, often reducing the total number of cameras required or allowing an expanded surveillance area. IP systems typically only require a single UTP cable for each camera, which can be run to the nearest network switch rather than to the DVR or server. This allows monitoring of multiple sites to be centralized rather than locally monitored. These quality advantages and convenience factors help to reduce the total cost of ownership of an IP-based security and surveillance system.

## Optimizing Video Security and Surveillance with the Addition of Fiber Optics

Many security professionals are finding that the quality, bandwidth and distance needed to perform even the most basic surveillance are beyond the reach of coaxial and UTP cabling. Due to the inferior transmission quality over coaxial cabling, analog CCTV systems are most effective when cable runs are limited to distances of 185 meters (approx. 600 feet). Despite their many advantages, IP-based video systems also face a serious distance limitation of 100m (328 ft) or less over UTP cabling infrastructure. These limitations create unnecessary challenges when trying to install or monitor the many outlying locations of a typical surveillance network.

The additional provisions required to guarantee the video signal's transmission strength (such as the use of signal amplification, ground fault correction and surge protection) inevitably increase the cost of the system considerably, making alternative cabling methods more attractive. In fact, the use of fiber optic cables will allow for cable runs of 2 kilometers (6,561 ft) on multimode and even greater distances on single mode fiber. In addition to distance extension, fiber optic cabling also presents a number of other unique benefits not present in either coax or UTP cabling:

- Smaller size and better tensile strength, making it easier to install when pulling through conduit or in overhead cable trays
- High degree of security since fiber is inherently difficult to tap into without detection
- Immunity to electrical interference such as electromagnetic interference (EMI) caused by external sources like motors and transformers in industrial and power utility applications
- Immunity to radio frequency interference (RFI) from consumer devices and digital circuits in computer and networking equipment
- Immunity to high voltages found in fluorescent lights, card access door strikes and outdoor lighting systems or induced voltages (ground loops) which cause picture distortion and audio interference
- Higher bandwidth
- Improved reliability and overall transmission performance

Local area networks (LANs) very commonly deploy fiber optic cabling as the network backbone between buildings or in vertical risers of multi-story buildings. Using this existing infrastructure is a logical and economical alternative to making the necessary accommodations for the distance and quality issues common to coax and UTP video systems. The remaining challenge for most video security professionals is how to access this fiber since many cameras and monitors are not available with fiber optic ports and the existing video security and surveillance system was designed and installed with coax or UTP cabling. Transition Networks offers a wide variety of products to convert electrical video signals to an optical format, allowing you to improve the quality, bandwidth and distance of your existing system.

## Easing the Transition to Fiber

Whether the need is to extend the distance of an existing network, extend the life of non-fiber based equipment or simply utilize existing fiber optic infrastructure, media conversion can be a cost-effective way to integrate fiber optic cabling into an existing copper or IP-based video security system. Media conversion products, such as Transition Networks' ION Multi-Service Integration Platform, transparently connect one type of media, or cabling, to another – for instance copper to fiber or UTP to fiber. In addition, video media converters can be designed to perform many other functions, such as transporting the serial information necessary for control of PTZ cameras or even providing a means to transport the video over the Ethernet-based LAN.

**KEY**

- PoE (Power over Ethernet)
- Fiber Optic Cable
- Coaxial Analog Cable
- Copper Ethernet Cable

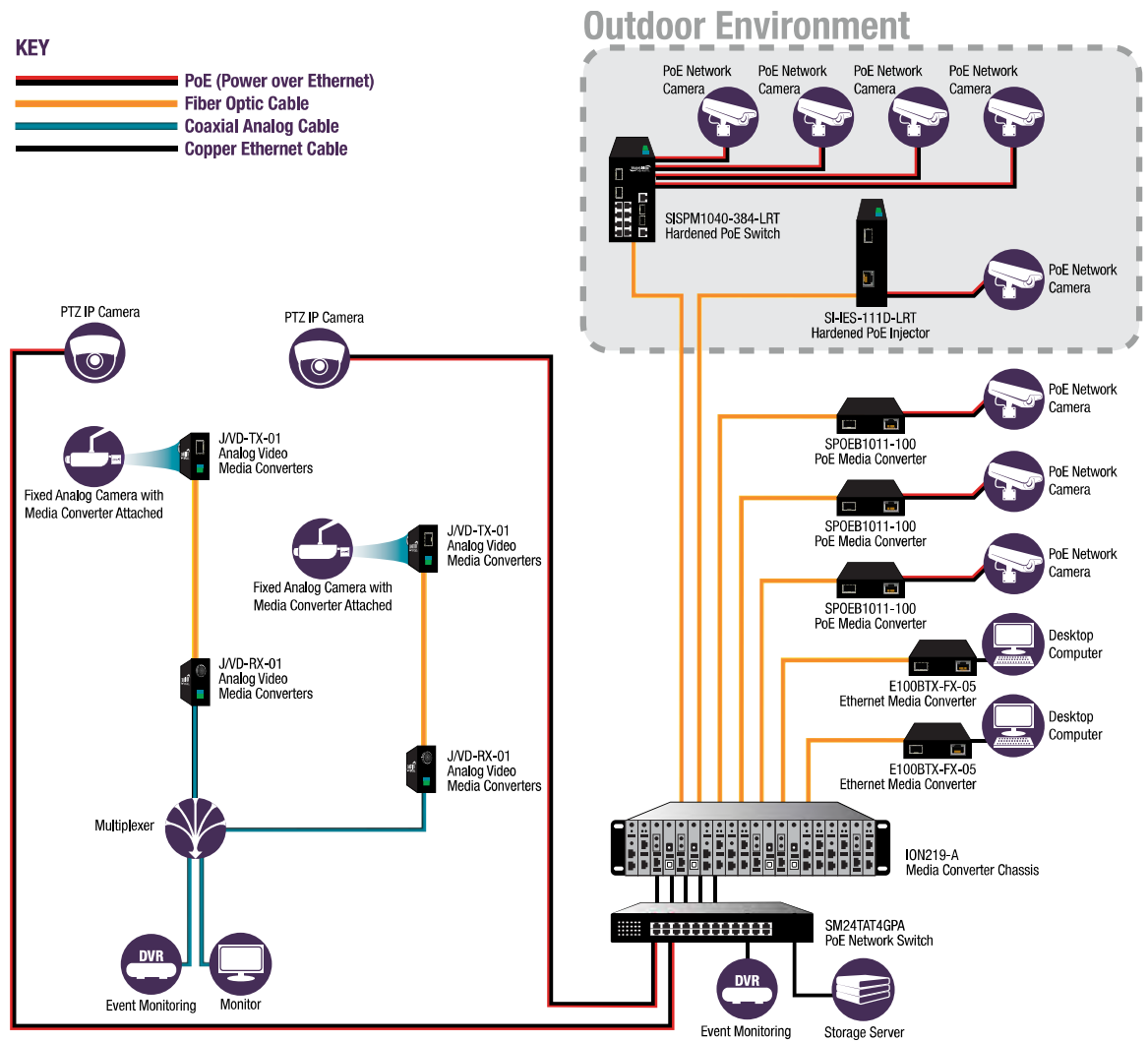

Fig. 3: Hybrid Video Security System with Media Conversion

## Inserting Power into Video Security Networks (PoE and PoE+)

Power over Ethernet (PoE) describes a system that safely transfers electrical power along with data to remote devices over standard data cables in an Ethernet network. By remotely supplying power from a central location, powered devices such as network cameras can be located up to 100m away from the power supplying equipment. Utilizing PoE reduces installation costs by eliminating the need for AC power outlets or bulky AC power adapters and also simplifies installation by using a single cable for transmission of both data and power. Furthermore, PoE allows centralized power backup to ensure continuous operation during power interruptions. Power management can also be centralized so devices can be remotely powered down during periods of no usage. Finally, PoE provides a safe method for powering because it will not damage non-PoE devices or legacy equipment. Power can be generated midway along the 100m Ethernet segment (mid-span PoE) or at the end (end-span PoE) to extend the Ethernet segment up to an additional 100m.

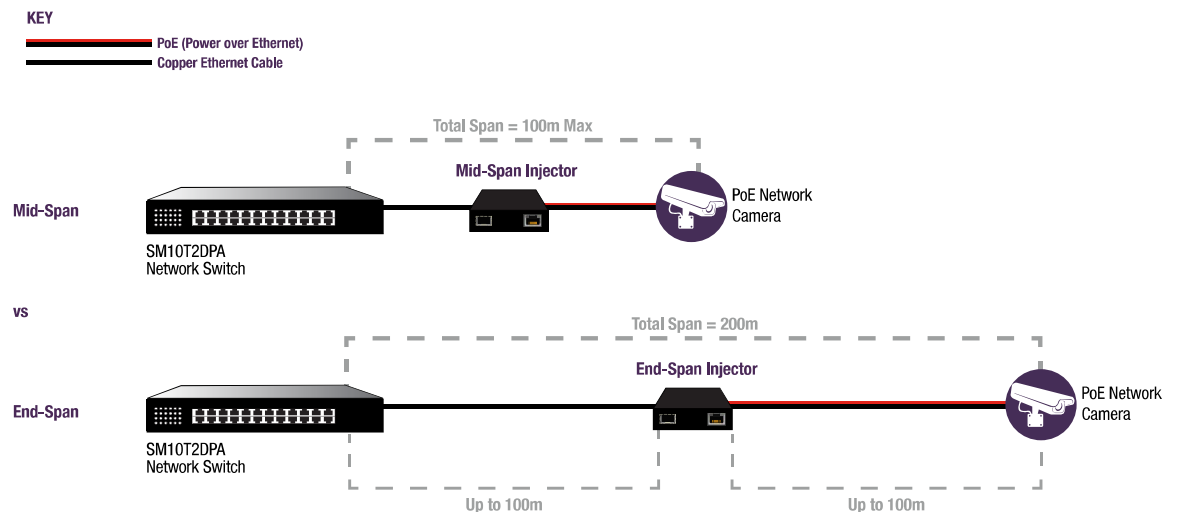

Fig. 4: Mid-Span vs End-Span Injectors

The evolution to higher quality IP cameras with PTZ and other enhanced features requires higher power than traditional security network elements utilized. Original versions of PoE devices supplied up to 15.4 Watts of DC power to each class 3, 4 or 0 device. Since some power dissipates in the cable, only about 12.95W is then available to the powered devices. The power supply equipment output of 7W for class 2 devices, such as IP cameras, results in even less (about 6.49W) power available to the powered device. Since newer enhanced devices can require 30W power, PoE+ devices are now available to accommodate these higher power requirements. Transition Networks offers a wide assortment of PoE/PoE+ remote powered solutions to easily upgrade network infrastructures.

## Products for Optimizing Security Networks

Transition Networks offers a thorough line of products for optimizing video security and surveillance networks and helping to protect your existing investment.

### Analog Video Products

**Analog Video Transmitters and Receivers:** Connect unidirectional analog video devices over fiber. Analog composite video media transmitters allow a CCTV signal from a camera to be transmitted on a single strand of multimode or single mode fiber up to about 10km. Analog video receivers convert the optical signal back to an analog composite video signal. Features such as automatic gain control maintain the desired quality of video's contrast and brightness for extended distances.

**Analog Video Media Converters:** Powered devices that convert an analog video signal on coax to a fiber optic medium. Analog to fiber media converters can be used to connect equipment with copper ports to equipment with fiber ports, as well as extend surveillance reach over fiber. Media converters are a cost-effective method for integrating fiber optic cabling into existing networks to improve quality and coverage of the security and surveillance system.

### IP Video Products

**Ethernet Media Converters:** Powered devices that convert an IP-based video signal on UTP to a fiber optic medium. Ethernet media converters can be used to connect equipment with copper Ethernet ports to equipment with fiber ports, as well as to extend surveillance reach over fiber. Ethernet media converters are available for Ethernet, Fast Ethernet and Gigabit Ethernet and can pave the way to upgrade networks for higher speeds. After a fault condition has been corrected, Transition Networks media converters automatically re-establish the link when connected to auto-negotiating switches, whereas other manufacturers' converters require user intervention.

**Power over Ethernet (PoE) Media Converters:** Powered devices that convert an IP-based video signal over UTP to a fiber optic medium, as well as inject 15W of -48 VDC power necessary to power remote IP cameras or other data terminal equipment connected to the UTP cable.

**PoE+ Media Converters:** Powered devices that convert an IP-based video signal over UTP to a fiber optic medium, as well as inject 30W of -48 VDC power necessary to power advanced feature remote IP cameras or other high powered data terminal equipment connected to the UTP cable.



**PoE Injectors:** Provide 15W power for PoE enabled network devices such as IP cameras over standard Ethernet cables without the need to install additional power outlets and electrical cabling. Mid-span and end-span injectors allow users to take advantage of PoE technology while protecting previous investments in non-PoE supported devices such as standard Ethernet switches. PoE injectors provide a simple, cost-effective, IEEE compliant solution to upgrade existing infrastructure with PoE.

**PoE+ Injectors:** Provide 30W power for PoE enabled network devices, such as advanced PTZ IP cameras, over standard Ethernet cables without the need to install additional power outlets and electrical cabling. Mid-span and end-span injectors allow users to take advantage of PoE technology while protecting previous investments in non-PoE supported devices such as standard Ethernet switches. PoE+ injectors provide a simple, cost-effective, IEEE compliant solution to upgrade existing infrastructure with PoE power.

**Hardened PoE+ Injectors:** Industrial version of PoE injectors with a hardened design to reliably operate in harsh environments, such as outdoor enclosures, while providing power to devices over UTP cabling.

**PoE Network Switches:** Connect and power wireless access points, network cameras and VoIP over fiber optic cable. Multiple management and security features are available.

**Hardened PoE+ Network Switches:** Industrial version of PoE+ switches with a hardened design to reliably operate in harsh environments, such as outdoor enclosures, while providing all the benefits of PoE+ power.

**Time Division Multiplexing (TDM) over IP Converters:** Deliver switched, transparent, synchronous ISDN data services across asynchronous packet networks over IP or Ethernet. Transition Networks' comprehensive range of highly-featured professional TDM over IP or Ethernet converter products deliver very high quality clocked V.35 and X.21/V.11 services.

**Coarse Wave Division Multiplexing (CWDM) Products:** CWDM can help alleviate fiber exhaustion and increase fiber bandwidth. CWDM wavelength-specific optical ports on Transition Networks' complete line of media converters and switching products allow the full benefit of CWDM technology while scaling existing infrastructure with a low-cost, plug-and-play platform.

**Small Form Factor Pluggable (SFP) Modules:** Condensed, modular transceivers which are hot pluggable for use within Gigabit Ethernet switches, routers and fiber channel switch infrastructure. SFP modules provide flexibility by allowing users to determine the fiber type (single mode or multimode), connector style, and distance requirements to best suit their existing infrastructure. SFP modules are compatible with Multi-Sourcing Agreement (MSA) and are ideal for high-density media converter applications, saving valuable rack space.



### Universal Products

**Managed Media Converter Chassis:** Allows comprehensive management of media conversion equipment through a centralized intelligent chassis with enhanced SNMP management software. Transition Networks understands that every network is managed differently and that various security levels and management interfaces are often required. A variety of security features are available with Focal Point, our integrated SNMP management software, which also saves time configuring the network with its user-friendly GUI or web-based interface.

### Summary

With over 25 years of expertise in network migration, Transition Networks is a valuable partner in planning and implementing changes to your network. The quality of the products you incorporate into your network is extremely important, which is why most Transition Networks products are backed by a lifetime warranty as well as our unsurpassed customer support. Transition Networks is ISO 9001 and ISO 14001 Quality certified. Our products are compatible with IEEE standards, as well as with other important elements in your network, allowing you to transition your security and surveillance network for today's needs and cost-effectively future-proof it for tomorrow. For assistance in selecting the specific products to optimize your network, please visit [transition.com/contact/](http://transition.com/contact/).