

# Rotarybolt™ Z<sup>02</sup> Electronic Safe Lock



## Installation Instructions

### Mounting Considerations:

- Sargent & Greenleaf Rotarybolt Z<sup>02</sup> electronic safe locks are designed to use the same mounting screw locations as common S&G mechanical and electronic safe locks. In many instances it can easily be mounted in place of these locks.
- The Rotarybolt Z<sup>02</sup> lock is available in left-hand and right-hand models. Select the correct model for your application. The illustrations on page 2 will help you determine which one you need.
- The keypad diameter is 4 inches (101.6 mm). This is slightly greater than the diameter of standard dial rings for mechanical locks. This allows the keypad to cover any scratches or paint blemishes left by the old lock.
- A fresh Duracell® alkaline battery should be installed in the keypad, and the keypad should be connected to the lock to check for proper operation prior to installation. Follow the procedures outlined in the operating instruction booklet.
- Modifications to the lock are not recommended and will void the manufacturer's warranty.
- A minimum distance of .150 inch (3,8 mm) is recommended between the end of the lock case containing the bolt and the safe's blocking bar or cam plate (which is normally blocked by the extended lock bolt). Maintaining this clearance will allow the lock to achieve optimum performance.



Sargent & Greenleaf, Inc.  
A Wholly Owned Subsidiary of Stanley Security Solutions, Inc.  
PO Box 930  
Nicholasville, KY 40356  
Phone: (800)-826-7652 Fax: (800)-634-4843  
Phone: (859)-885-9411 Fax: (859)-887-2057

Sargent & Greenleaf S.A.  
9, Chemin du Croset  
1024 Ecublens, Switzerland  
Phone: +41-21 694 34 00  
Fax: +41-21 694 34 09

## Left-hand or Right-hand?

The Rotarybolt Z<sup>02</sup> lock uses a very efficient bolt design that allows it to “fold” into the lock case when the correct code is entered and the safe’s boltwork presses against the side of the lock bolt. This provides for smooth operation and long life. It also requires the lock to be *handed*, which means the direction from which the safe’s boltwork presses against the Rotarybolt bolt determines which model must be used.

The illustrations below should make it easy for you to select the correct model for your safe. The arrows represent the direction in which the safe’s blocking bar (straight arrow) or cam plate (curved arrow) moves when the door’s handle is being turned to unlock the safe.

**The four locks immediately below are all the same left-hand model (Model 2002-300 Rotarybolt Z<sup>02</sup>). Each is shown in one of the four standard mounting positions. Each is depicted as it would be seen by looking at the back (inside) of the safe door.**

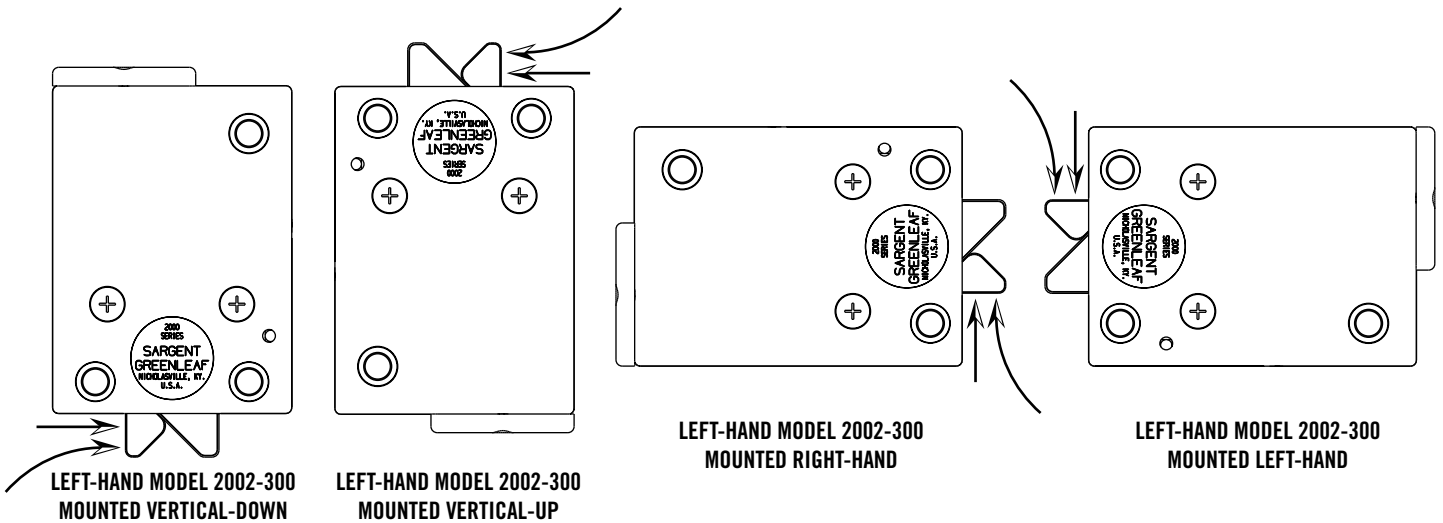

**The four locks immediately below are all the same right-hand model (Model 2002-200 Rotarybolt Z<sup>02</sup>). Each is shown in one of the four standard mounting positions. Each is depicted as it would be seen by looking at the back (inside) of the safe door.**

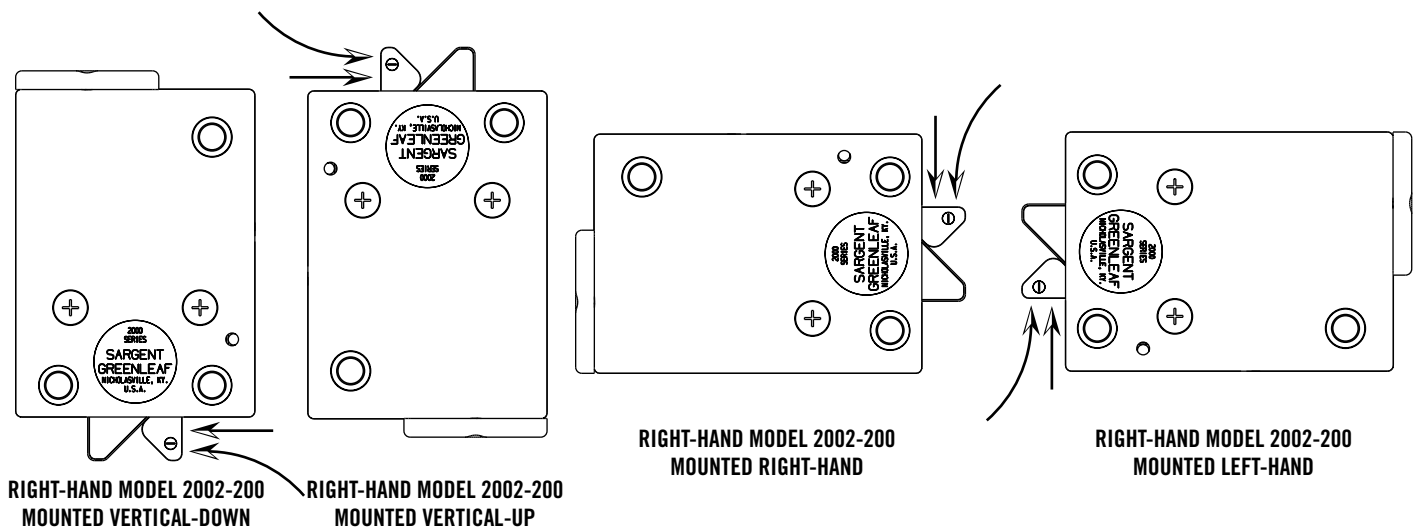

## Installation Notes

Although the Rotarybolt Z<sup>02</sup> lock is easy to install, we recommend the following procedures be performed only by an experienced locksmith or safe technician. Your safe may incorporate relocking devices that are attached to the lock body. Misalignment or detachment of these devices can result in a lockout; a condition where the safe probably cannot be opened without damage.

The Rotarybolt Z<sup>02</sup> lock requires a 9-volt alkaline battery. We recommend fresh Duracell® batteries. Do not use an old or partially drained battery in your lock. A new battery will power your lock for approximately 8,000 openings when used without the time delay feature.

---

## Installation . . .

### Step 1

Remove the existing lock (if one is present). The mounting plate should be smooth and flat, with either 1/4-20 or M6 mounting screw holes. The wire channel (spindle hole) must have a minimum diameter of 5/16 inch.



### Step 2

Use a reamer or file to remove any sharp edges from the wire channel (spindle hole) that could damage the wire cable.

Run the connector through the wire channel. Gently pull the connector and all excess cable to the outside of the safe. Make sure the cable is not crimped or stressed at any point. It is also very important make sure the cable is not crimped or folded against itself under the lock body as you prepare to fasten the lock to the mounting plate.

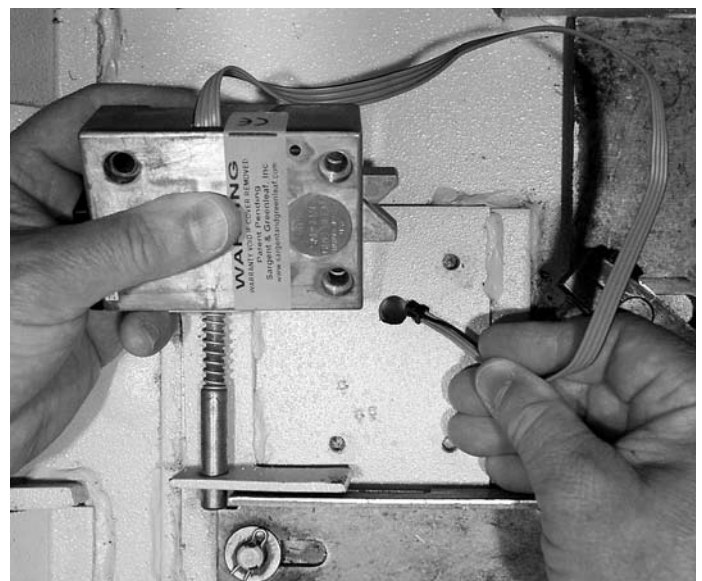

### Step 3

Once you've double-checked to make sure the wire cable is not crimped or in contact with any sharp surface, attach the lock to the safe's mounting plate. Use the three  $\frac{1}{4}$ -20 or M6 (metric) mounting screws provided. Tighten securely so the lock is attached firmly to the plate.

The lock incorporates a bolt-though cover that allows the mounting with the cover in place. Removing the cover voids the product warranty.



### Step 4

Once the lock is fastened into place, check to make sure all three mounting screws are tight. Avoid bottoming a screw in a mounting plate hole. Although the screw will feel tight, it will not be holding the lock firmly against the plate.

Ensure a gap of at least .150 inch (3.8 mm) between the end of the lock case and the blocking bar of the safe's boltwork. The gap to be measured is indicated by the space between the arrows.



### Step 5

Pictured is an installation that requires attachment of the safe manufacturer's relock device plate to the lock cover using the cover screws or a suitable substitute. If your situation is similar, be sure the thickness of the relock device plate is not great enough to prevent the screws from engaging the lock case by at least four threads. If necessary, use longer 8-32 machine screws to insure proper fit. The cover screw holes are only tapped as deep as the original screws, so using other screws may require tapping the screw holes slightly deeper into the lock case.

If the relock device plate is not properly attached, it may come loose. The safe will then have to be forcibly opened.

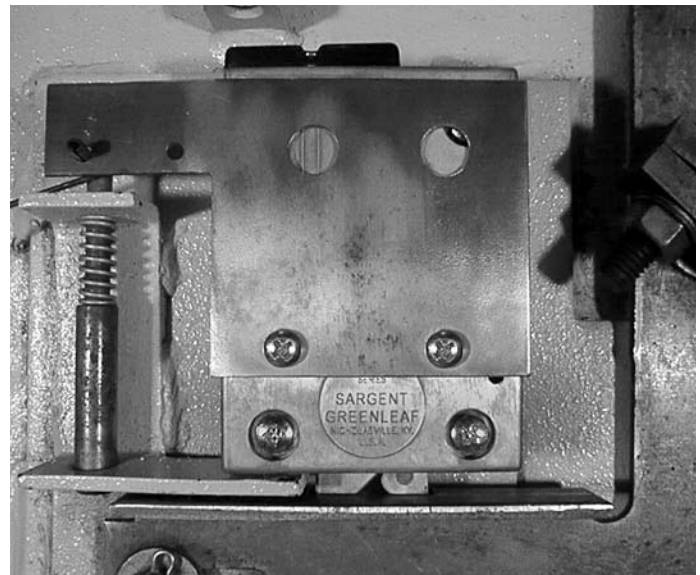

### Step 6

The lock cannot function properly if it binds against the safe's boltwork. It is sensitive to bolt side pressure.

This photo shows boltwork in the fully locked position which places pressure on the side of the lock bolt. It could prevent the lock from opening.

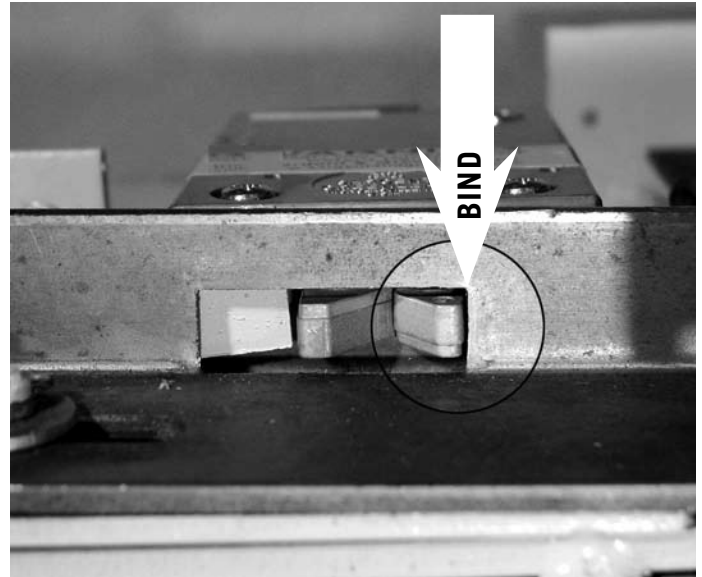

### Step 7

The boltwork bind has been relieved by removing a small amount of material from the right side of the blocking bar's bolt opening. When the safe's boltwork is fully thrown to the locked position, there is air space on all sides of the lock's bolt.

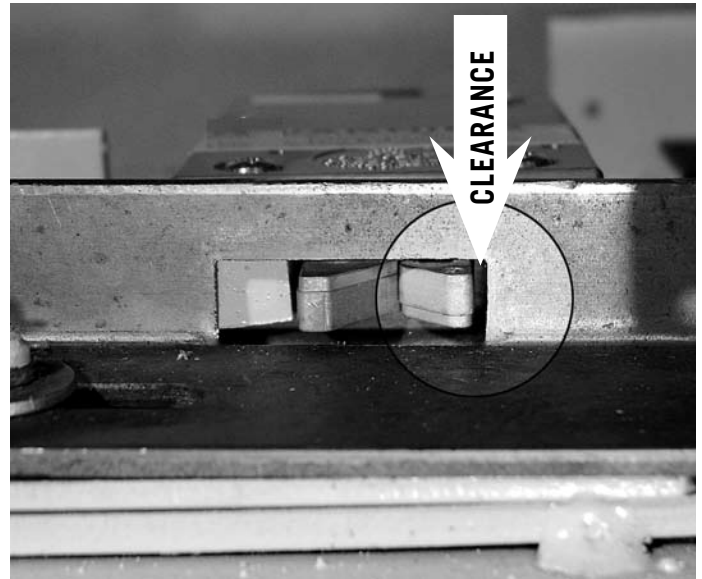

### Step 8

The keypad comes with two pairs of mounting screws. The silver colored pair is 8-32, and the reddish pair is M4 (metric). Determine which pair fits the keypad mounting screw holes in your safe's door, then discard the other pair.

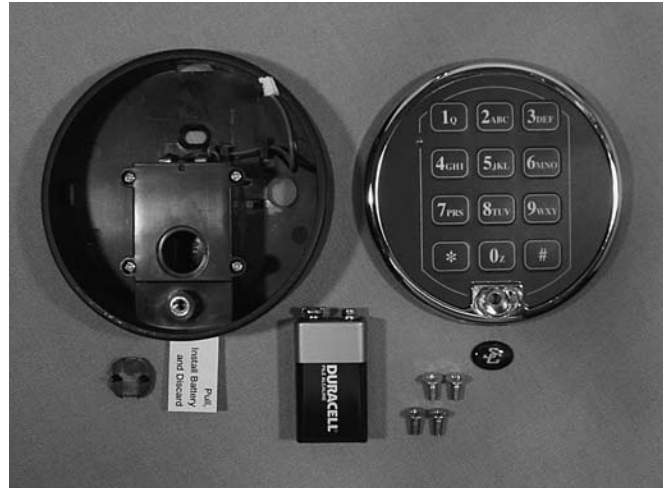

### Step 9

Pull on the yellow tab to remove the battery holder from the base. Once the holder is out, peel off the tab and discard it.

*Note: If you will not be installing a battery upon completing keypad installation, leave the yellow tab in place on the battery holder.*

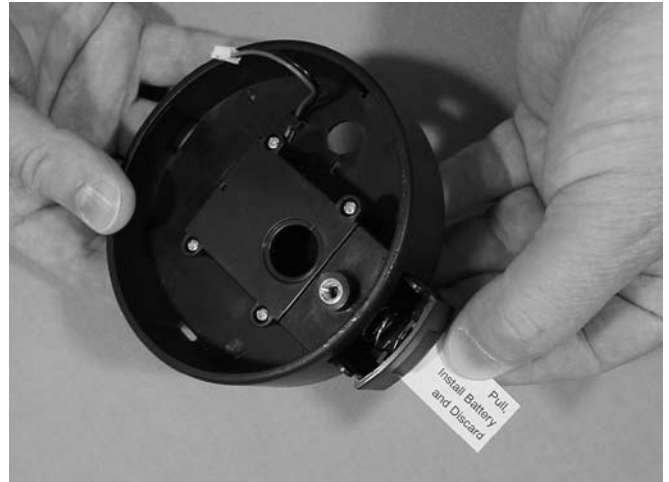

### Step 10

The lock cable has already been pulled through the hole in the door. Place the cable into the recessed channel in the back of the keypad base, tucking it under the guide tabs as shown.

It's important to make sure the cable is kept in the recessed channel so that it will not be crushed or crimped when the base is fastened to the safe.

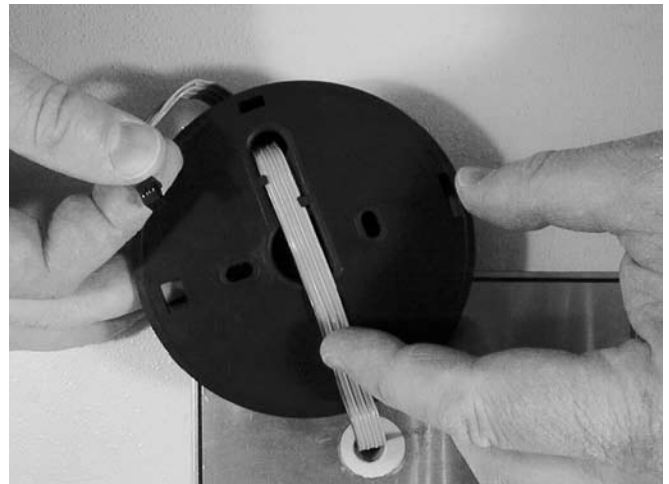

### Step 11

Move the base toward the safe door, gently pulling on the cable to take up any slack. Pull all excess cable through to the front of the keypad base, and make sure it stays in the recessed channel in the back of the base.

When you finish this step, the base should be flat against the safe door, all excess cable should be pulled to the front, and the cable under the base should be in the recessed channel.

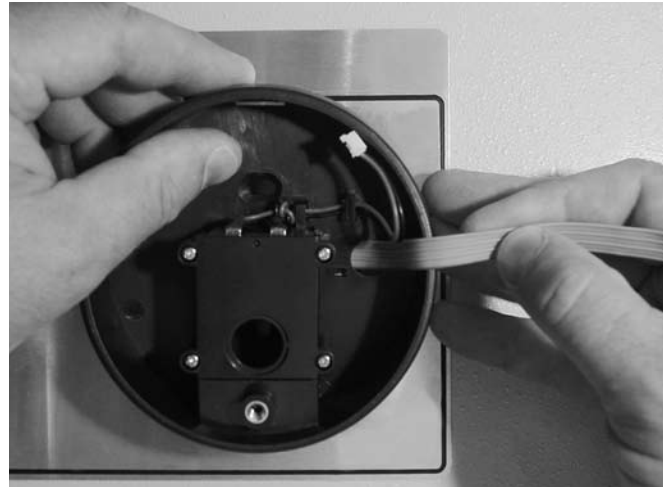

### Step 12

With the keypad in position on the safe door, install the two mounting screws. The holes in the keypad base will line up with the existing mounting holes in the safe door.

The bottom screw is installed through the battery holder cavity. You may find it helpful to hold the screw with tweezers or needle-nose pliers while you get it started in the hole.



### Step 13

Locate the small, black, plastic disc included with the keypad components. Insert it into the battery holder housing with its two legs pointing away from the keypad base and in line with the two base mounting screws.



**Step 14**

When the disc is positioned correctly, moderate pressure will cause it to snap into place.

The disc increases the tamper resistance of the keypad.

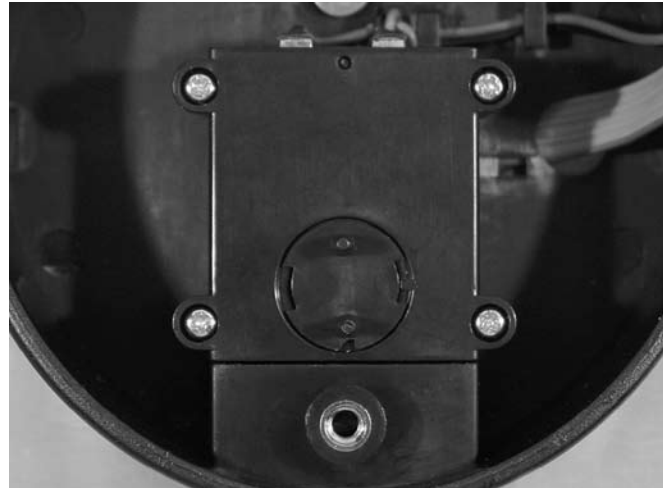

**Step 15**

Plug the black connector that is at the end of the lock cable into the matching black receptacle on the underside of the keypad. It is designed to insert only when oriented correctly.

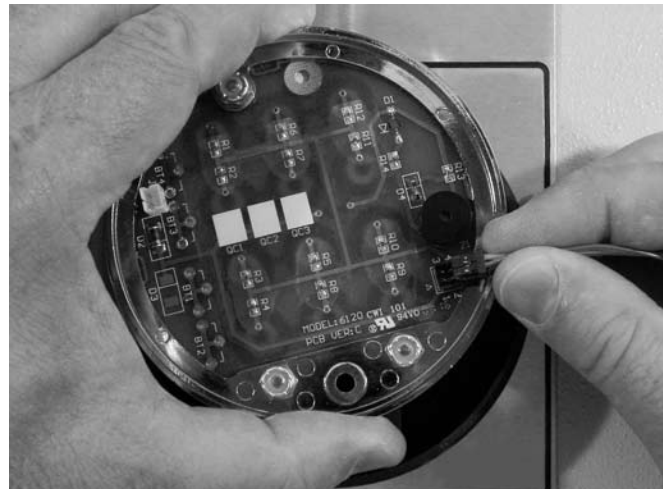

Line the two raised ribs on the connector with the matching slots in the receptacle, as shown.

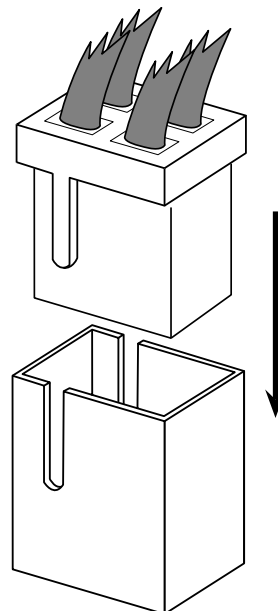



### Step 16

Insert the white power connector into the matching white receptacle on the keypad circuit board. Like the lock cable connector, it will only insert fully when it is oriented correctly.

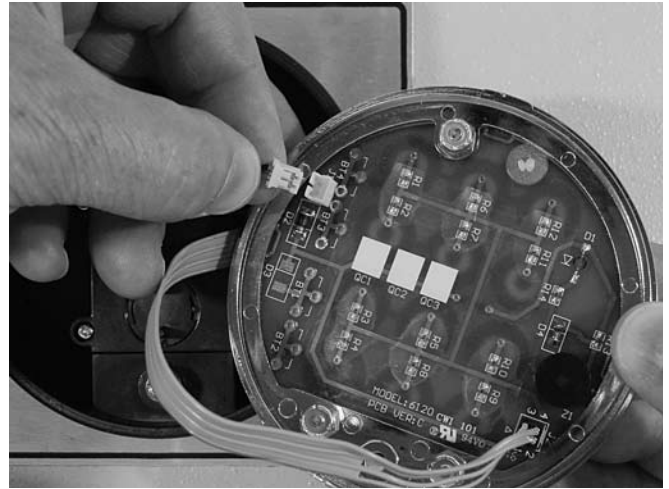

### Step 17

Place a 9-volt alkaline battery (Duracell® brand is recommended) into the battery holder.



Note that the top of the battery holder is shaped to allow the battery to install only in the correct orientation.



## Step 18

Slide the battery holder into its receptacle in the bottom of the keypad base. It will snap into position.

Carefully turn the keypad over and hold it in your hand while you check the operation of the lock at least three times. You can do this by entering the factory default master code (1-2-3-4-5-6-#), then turning the safe handle to make sure the boltwork retracts to the unlocked position. Perform these three checks with the safe door **OPEN**.



## Step 19

Once you are satisfied the lock is operating as it should, remove the battery while you complete the installation.

Route the lock cable around the top of the battery holder area so it will not be crushed when the keypad is placed on the base.



## Step 20

Install the keypad onto the base. Insert it into the base at the top first, where a small recess in the base captures a matching projection on the keypad's rim. The keypad will snap into place when you apply moderate pressure.

Use a flat bladed screwdriver to install the one-way security screw as shown. It cannot be easily removed without a special tool. This assembly is a VdS approved tamper resistant keypad.

If a VdS tamper resistant keypad is not needed, you may want to use a standard 8-32 X .250 inch machine screw instead. If this is done, the assembly will not be VdS approved

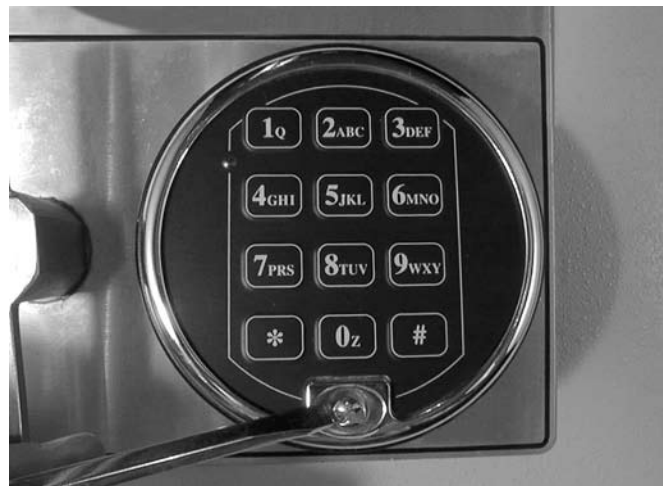

### Step 21

Once the screw is tightened in place, remove the protective backing from the S&G self-stick logo button, align it carefully, and press it into the recess where the screw was installed. Once pressed firmly, its adhesive will hold it in place.



### Step 22

Re-install the battery holder. It will snap into place when fully inserted.



### Step 23

The installation is complete. Refer to the Rotarybolt Z<sup>02</sup> lock's operating instructions to learn about its many useful features.





Sargent & Greenleaf, Inc.  
A Wholly Owned Subsidiary of Stanley Security Solutions, Inc.  
PO Box 930  
Nicholasville, KY 40356  
Phone: (800)-826-7652 Fax: (800)-634-4843  
Phone: (859)-885-9411 Fax: (859)-887-2057

Sargent & Greenleaf S.A.  
9, Chemin du Croset  
1024 Ecublens, Switzerland  
Phone: +41-21 694 34 00  
Fax: +41-21 694 34 09