

S&G® Alarm Module

Remote Disable/Duress/Tamper Module

Installation and Connection Instructions



General Information:

- As with all electronic devices, it is recommended that installers wear a grounding wrist strap whenever installing or making connections to the module.
- Clearly mark any wires you may disconnect to aid you in reconnecting them.
- When disconnecting wires or cables terminated with a plug, always pull on the plug, never on the wires.
- Make sure you have confirmed with the container manufacturer that there is no risk of electrical shock when working inside the container. If the possibility of electrical shock exists, make sure you know how to eliminate or mitigate that risk before attempting the retrofit.
- The module is mounted with four screws.
- The duress (silent alarm) feature of the module can only be used with the S&G lock models 6124, 6125, 6126, 6127, 6128, 6129, 2006, and 2007. The module can easily be added to new or existing installations.
- Unless the module is installed within 10" (25 cm) of the lock, S&G lock extension cables will be required. The total cable length between the module, lock, and keypad must NOT exceed 3 meters.
- Care must be taken to protect wiring from being damaged or broken during installation and use when the safe is in service. Avoid routing the wires near moving parts of the safe and boltworks. Use wire tie devices to secure all wires and cables that must be routed near moving parts.
- The module has very low power consumption and is powered from the alarm system 12VDC regulated power supply.

Installation Steps:

Step 1: Locate smooth flat area on the inside of the safe door to mount the module. Area should be within 10" (25 cm) of the lock. Drill and tap four holes for mounting the module. The mounting orientation of the module is not important.

Step 2: Caution: To prevent possible ESD damage to the module during installation, the module and installer must be grounded. Also, do not touch or probe the PC Board at any points other than the connectors, terminals or solder tabs. Remove the module cover (2 screws). Use a wire tie for each connection to the terminal strip on the module base for strain relief of wires coming into the module. Mount the module with four mounting screws (not provided). Route the keypad cable from the module to the keypad as required.

Sargent & Greenleaf, Inc.

PO Box 930, Nicholasville, Kentucky 40340-0930 USA
Phone (859) 885-9411
Phone (800) 826-7652
FAX (859) 887-2057
FAX (800) 634-4843

Sargent & Greenleaf S.A.

9, chemin du Croset
1024 Ecublens, Switzerland
Phone +41-21 694 34 00
FAX +41-21 694 34 09

Installation Steps *(continued)* :

Step 3: For motor locks (below, lock on the left), remove the self-adhesive, foam wire protector from the lock cable and gently pull lock cable out of the cable slots on the bottom of the lock. For Titan series locks (below, lock on the right), it may be necessary to carefully pull the cable through the lock case hole so that it no longer runs through the lock from back to front. Carefully route the keypad cable from the module through the same channel where you removed the lock cable, and mount the lock in accordance with the appropriate lock installation instructions. Note: The lock cable remains entirely inside the safe for connection to the module

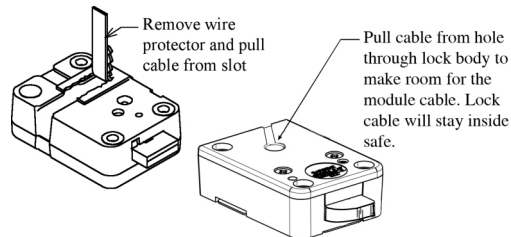

Step 4: Plug the lock cable into the module connector and use a wire tie to secure the lock cable.

Step 5: Complete installation of the lock keypad in accordance the lock installation instructions.

Wiring Guidelines:

- Route all wires to utilize the wire tie points on the module for strain relief, and break away the plastic base as required to route wires under the module base.
- Wire size range for wiring terminals: 16 to 26 AWG (solid or stranded wire)
- Suggested wire strip length is .15" (4 mm).
- Maximum terminal screw torque is 2 in-lb (0.4 Nm).
- All alarm module connections are indicated on the module label as shown below.
- Solder terminals are provided for the terminal resistors R1 through R5 shown below. The resistors must be soldered in place for the desired application.

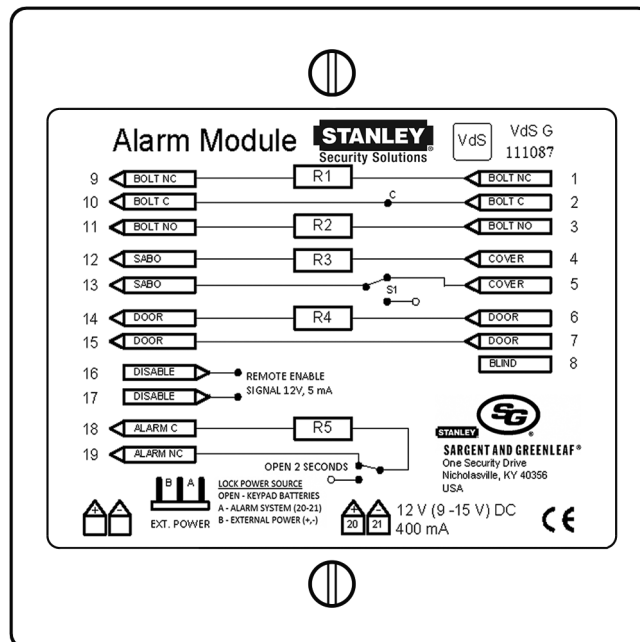

Wiring Instructions:

- For the lock bolt alarm interface, connect the lock bolt position indicator common wire (black wire) to module position #2. Connect the normally closed (NC) wire (red wire) to position #1. Connect the normally open (NO) wire (green wire) to position #3. If only two wires are used, short the unused position to position #2 using a resistor.
- For container door sensors, connect to module positions #6 and #7.
- For the container door inner cover switch, connect to positions #4 and #5.
- For alarm interface connection to a central alarm system:
 - Lock Bolt Position—connect module position #10 to common. Connect position #9 for normally closed (NC). Connect to position #11 for normally open (NO).
 - For tamper sensing (SABOTAGE), connect a normally closed (NC) circuit at module positions #12 and #13.
 - For container door arm/disarm, connect to module positions #14 and #15.
 - For remote disable, connect to module positions #16 and #17. Required voltage is 12VDC \pm 15%. Polarity is unimportant.

Power Source Selection:

Caution: *to prevent possible ESD damage to the module during the change procedure, the module and installer must be grounded. Also, do not touch the other components on the printed circuit board assembly. Before installation, remove 4 base plate mounting screws and remove base/PC board assembly from the module enclosure.*

An internal circuit board pin jumper is used to select the power input source:

- Remove the jumper to use batteries located in the keypad to power the lock system. *Note that module power is still supplied from the alarm system to terminals 20 and 21.*
- Place the jumper between position A and the center pin to use power from the alarm system to power the lock system (input the power to module terminals 20 and 21 observing the polarity indicated).
- Place the jumper between position B and the center pin to use power from an external power supply to power the lock system (input the power to unnumbered terminals marked “+” and “-” observing correct polarity. Note that power from the container’s alarm module is always connected to terminals 20 and 21 as noted above.

Module Operation:

After installation of the module, the lock must be programmed to enable the duress function if desired. See programming instructions for the appropriate lock model for the keypad programming sequence to activate and use the duress feature.

The remote disable feature of the module allows the lock to operate until the proper voltage signal (12VDC \pm 15%) is applied to module terminals 16 and 17.

Function Test:

- Connect the lock to the alarm interface.
- Extend the lock bolt if it is not already extended. Module positions #1 and #2 should show a closed circuit. Module positions #9 and #10 should show a closed circuit.
- Enter the lock code to retract the lock bolt. Module positions #2 and #3 should show a closed circuit. Module positions #10 and #11 should show a closed circuit.
- Activate the remote disable feature by applying 12VDC to module positions #16 and #17. Enter the lock code and verify that its bolt does not retract. The lock should not be openable as long as the voltage is applied to module positions #16 and #17.
- After enabling the duress function in the lock, check the duress by entering a duress code at the keypad (operating code with 1 added to the last code digit). The lock bolt should retract and module positions #18 and #19 should show an open circuit for approximately two seconds, then show a closed circuit.

Specifications . . .

Power requirements:

Voltage: 12VDC \pm 15%

Current: 20 μ A typical quiescent current

2mA typical operating current

2A peak operating current during lock operation (20 msec duration)

25mA typical during relay switching

Duress contact operation:

The duress (silent alarm) relay operation is a momentary contact change of state. A normally closed connection with a common is provided. The relay contacts change state one second after input of a duress code into the lock and will change back to their original state after two seconds.

Duress contact ratings:

Contact Rating: 1A @ 24VDC (resistive)

Expected Life: >>100,000 cycles at rated load

Maximum Switching Voltage: 150VDC or 125VAC

Minimum Switching Capability: Dry circuit

Remote Disable signal requirements:

Input Signal Voltage Rating: 5VDC - 15% to 12VDC + 15%

Current Requirements: 2.5mA typical @ 5VDC / 6mA typical @ 12VDC

Environment Class (VdS): II

IP Protection: IP3x

Ambient Temperature: -10° C to +55° C

Certification: VdS — G111087 (VdS Class C)

1.004" (25,5 mm)

