

# Metenova Mixer ZG10 Drive Unit

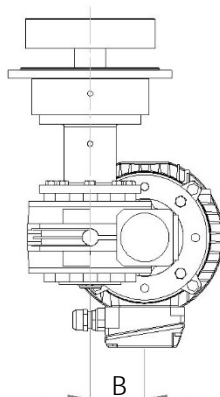
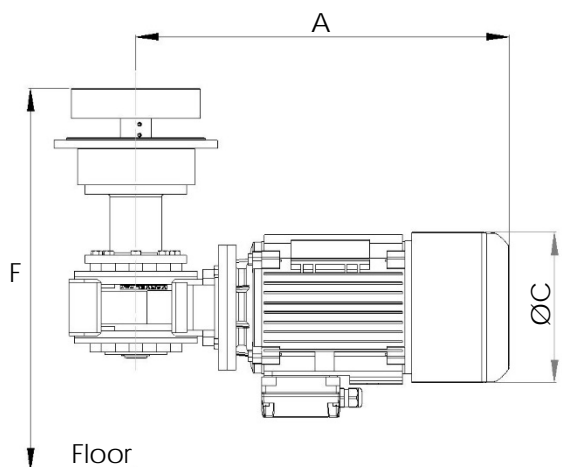

Option 1: RPM Sensor, Mix Head

Option 2: RPM Sensor, Shaft reading

Option 3: Lowering Device

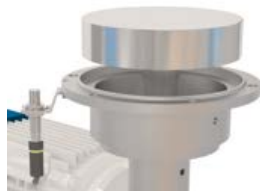

Part #	Description	
<b>ZG24502-H00433</b>	<b>ZG10 Drive Unit AC, E100, IP66</b>	
ZG00014-03083	RPM Sensor, Mix Head	Option 1
ZG00014-03193	RPM Sensor, Shaft	Option 2
ZG24502-02013	ZG10 Lowering Device E100	Option 3

A mm (in)	B mm (in)	ØC mm (in)	F mm (in)	Weight kg (lb)
479 (18.86)	70 (2.76)	196 (7.7)	530 (20.9)	46.0 (101.2)

**Motor:** 3.0 kW/ 4.0 hp @ 50 Hz / 3.5 kW/ 4.7 hp @ 60 Hz (4-pole - 7:1 Gear Box)  
**Voltage:** Δ230 / Y400 VAC @ 50Hz / Y460 VAC @ 60Hz (±5%)  
**Current:** 11.8A @ 230V/50Hz - 6.8A @ 400V/50Hz - 6.6A @ 460V/60Hz  
**Efficiency Performance Class:** IE2  
**Thermistors:** 2  
**Certified:** CE / C-UL-US  
**Protection class:** IP 66  
**Environment temp:** 0°C - 40°C (32°F - 104°F)  
**Min - Max rpm:** 24 - 245  
**Color:** In compliance with FDA  
**Gear box oil:** Food grade in compliance with FDA



- VFD with soft start must be used when operating the mixer.
- Items are individually packed and for traceability purposes marked with item & id no.
- Metenova Quality Assurance System ensures the quality and traceability at all stages of the process.

**Option 1: RPM Sensor, Mix Head**

**Pulses/turn:** 1  
**Output function:** 3-wire, NO contact PNP  
**Indicator:** Yellow LED  
**Temperature range:** -25°C-70°C (-13°F-158°F)  
**Operating voltage:** 10..65 VDC  
**Protection class:** IP67

**Option 2: RPM Sensor, Shaft**

**Pulses/turn:** 4  
**Output function:** 4-wire, NO/NC contacts PNP  
**Indicator:** Yellow LED  
**Temperature range:** -25°C-70°C (-13°F-158°F)  
**Operating voltage:** 10..30 V  
**Protection class:** IP67

**Option 3: Lowering Device**

Allows preventative maintenance of Mix Head and Male Post without having to remove the Drive Unit from the tank.