

Metenova Mixer ZG2 Mix Head

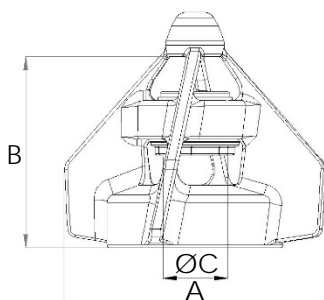

Part #	Description	
ZG51509-E00940	ZG2 Mix Head AL6XN SiC EP EPDM o-rings	
ZG00013-03136	Kalrez o-rings in lieu of EPDM	Option 1
ZG00013-03124	Silicone o-rings in lieu of EPDM	Option 2
ZG00013-03130	Viton o-rings in lieu of EPDM	Option 3

General information

A mm (in)	B mm (in)	Id Female Sleeve ØC mm (in)	Weight kg (lb)
86 (3.33)	68.5 (2.7)	18 (0.71)	1.0 (2.2)

Material:	AL6XN
Female Sleeve:	Silicon Carbide (SiC)
O-rings:	FDA & USP class VI * compliant EPDM
Surface Roughness:	Ra ≤ 0.5 µm (20 µin)
Surface Treatment:	Electro polished. Non animal origin polishing compounds are used.
Operating Temp:	5°C - 150°C (41°F - 302°F)
pH Range:	1 - 14

* Also applicable for optional o-rings

- Items are individually packed and for traceability purposes marked with item & id no.
- Metenova Quality Assurance System ensures the quality and traceability at all stages of the process.