

Metenova Mixer ZG7 Drive Unit

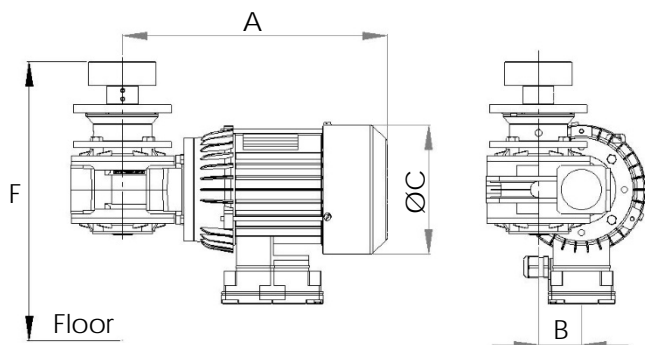

Option 1:
RPM Sensor, Mix Head



Option 2:
RPM Sensor, Shaft reading



Option 3:
Lowering Device



Option 4:
Transport Locking Device



Part #	Description	
ZG23502-F00444	ZG7 Drive Unit AC, E0, IE3	
ZG00014-03083	RPM Sensor, Mix Head	Option 1
ZG00014-03193	RPM Sensor, Shaft	Option 2
ZG23502-02006	ZG7 Lowering Device E0	Option 3
ZG23016-02721	ZG7 Transport Locking Device	Option 4

A mm (in)	B mm (in)	ØC mm (in)	F mm (in)	Weight kg (lb)
309 (12.16)	50 (1.97)	150 (5.9)	320 (12.6)	16.0 (35.2)

Motor: 0.75 kW / 1.0 hp @ 50 Hz / 0.9 kW / 1.2 hp @ 60 Hz (2-pole - 7:1 Gear Box)
Voltage: Δ230 / Y400 VAC @ 50Hz / Y460 VAC @ 60Hz (±5%)
Current: 3.3A @ 230V/50Hz - 1.9A @ 400V/50Hz - 1.9A @ 460V/60Hz
Efficiency Performance Class: IE3
Thermistors: 2
Certified: CE / C-UL-US
Protection class: IP 55
Environment temp: 0°C - 40°C (32°F - 104°F)
Min - Max rpm: 50 - 490
Color: In compliance with FDA
Gear box oil: Food grade in compliance with FDA



- VFD with soft start must be used when operating the mixer.
- Items are individually packed and for traceability purposes marked with item & id no.
- Metenova Quality Assurance System ensures the quality and traceability at all stages of the process.

Option 1: RPM Sensor, Mix Head

Pulses/turn: 1
Output function: 3-wire, NO contact PNP
Indicator: Yellow LED
Temperature range: -25°C-70°C (-13°F-158°F)
Operating voltage: 10..65 VDC
Protection class: IP67

Option 2: RPM Sensor, Shaft

Pulses/turn: 4
Output function: 4-wire, NO/NC contacts PNP
Indicator: Yellow LED
Temperature range: -25°C-70°C (-13°F-158°F)
Operating voltage: 10..30 V
Protection class: IP67

Option 3: Lowering Device

Allows preventative maintenance of Mix Head and Male Post without having to remove the Drive Unit from the tank.

Option 4: Transport Locking Device

Secures the Mix Head in place when transporting the tank without Drive Unit attached.