

02D Boom Reels and Racks

Boom Reel HSR H 1722 - 276787



The Heavy Hydraulic Storage Reel HSR H 1722 is designed for the safe and easy storage, deployment and recovery of oil booms. The HSR H reel is suitable for booms of any construction, allowing deployment from harbors and vessels efficiently.

The reel frame is manufactured from high quality marine grade coated steel. The spool is made of marine grade aluminum. The reel can be lifted securely from forklift channels on all four sides or from the dedicated lifting points located on the frame. The reel is designed to fit inside DNV containers and can be locked and secured by either the dedicated lashing points or the built-in ISO container corners.

The boom reel is operated by two planetary reduction gears with hydraulic motors, making it more powerful to operate. A load control valve is built into the reel hydraulics to increase safety during operations. The hydraulic hoses and components are installed inside the reels beams for increased protection. The reel is supplied with a protective canvas for storage.

The reel fulfills the Machinery Directive 2006/42/EC. Lifting points are designed in accordance with DNV 2.7.1



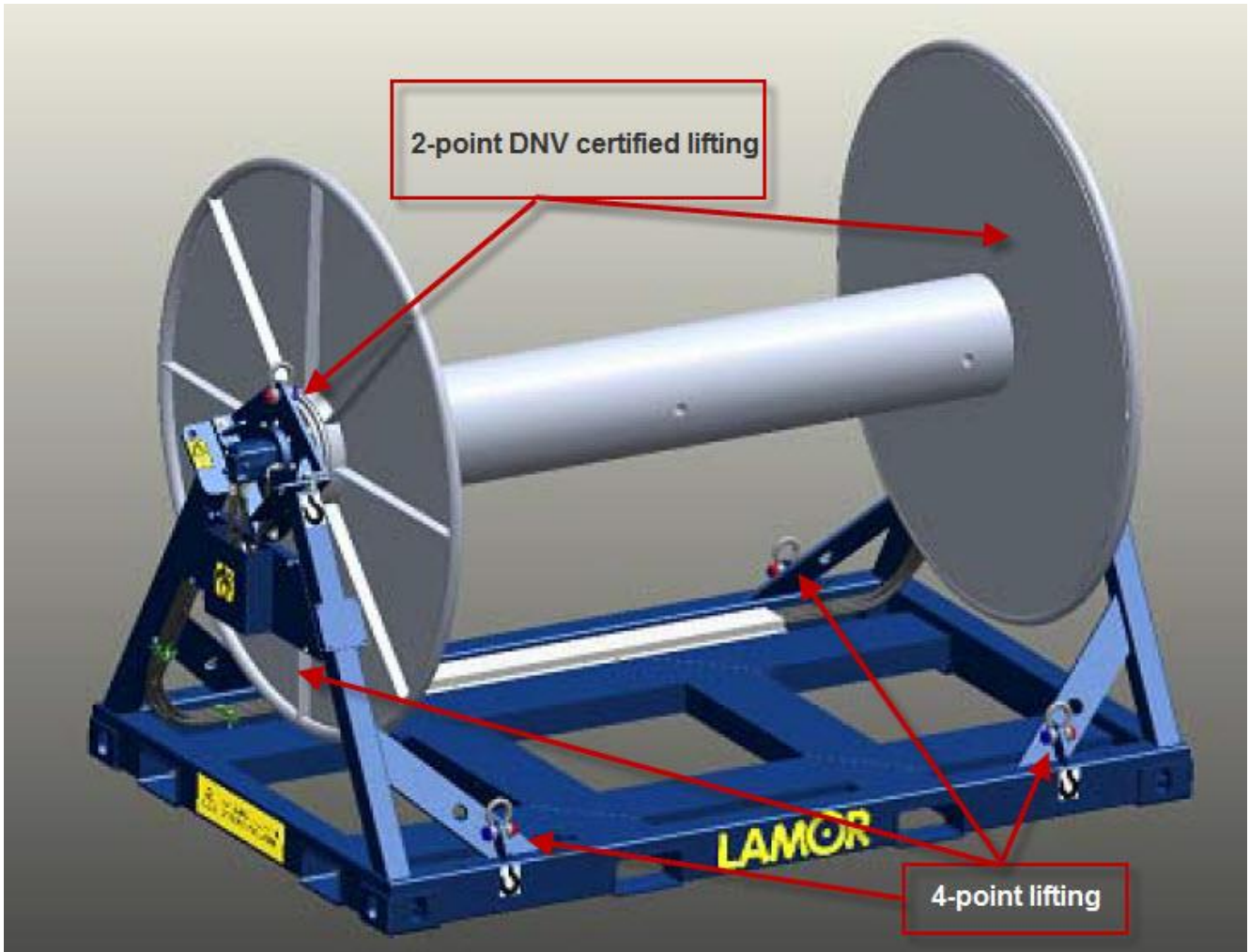

TECHNICAL SPECIFICATIONS

Length	2786 mm	110 in
Width	1721 mm	68 in
Height	2023 mm	80 in
Weight	877 kg	1933 lbs
Spool width	2200 mm	87 in
Capacity, HDB 2000	250 m	820 ft
Capacity, volume	4.8 m ³	170 ft ³
Frame/spool material	Steel/Marie grade alu.	
Hydraulic flow	15 l/min	4 gpm
Hydraulic pressure	150-210 bar	2175-3045 psi

BENEFITS

- Double planetary gear for high torque
- Load control valve for safe operation
- 2 point and 4 point lifting arrangements for secure lifting according to DNV 2.7.1
- Container corners for easy locking/securing
- Forklift channels on all 4 sides
- Fits inside DNV container