

# MODEL 500 ROLL-UP DOORS

The BETCO Model 500 Self-Storage Door is designed and manufactured with durability, quick installation, and ease of maintenance in mind. Features standard to this door eliminate the need for extra options or upgrades. Our doors are available in a variety of colors.



**DRUMS:** All drums are fitted with a grease filled, shielded radial ball bearing to contribute to a smoother operation and reduce wear and friction.

**MOUNTING BRACKETS:** Made of 16-gauge galvanized coated steel (12-gauge for doors over 9' wide or 8' tall) and designed to easily snap onto the guides, reducing installation time.

**HEAD STOPS:** Made of galvanized steel to prevent curtain over travel when raising the door.

**RATCHET SPRING TENSIONER:** Assembly is factory installed on the end of the door axle and allows precise fine tuning of initial spring tension.

**LATCHES:** Made of corrosive-resistant stainless steel that accommodates 2 shackled locks. Locks furnished by customer. Cylinder style latches and inside bottom latches are available upon request.

**BOTTOM BAR:** Roll formed acrylic coated galvanized steel reinforced with a 1-1/2" x 1-1/2" 14-gauge full width galvanized angle that extends fully into the guides. The PVC bulb stragal provides positive contact with floor.

Oil-tempered helical torsion **SPRINGS** are factory lubricated to reduce friction and corrosion while prolonging the spring cycle life.

**BARREL:** Full width galvanized steel barrel totally encloses the drums, springs and axle. Barrel-type construction reduces door sag, and improves operation.

**DOOR CURTAIN:** Galvanized 26-gauge and pre-painted with long lasting, Super Durable polyester paint. Thus yielding a stronger door and minimizing curtain damage overtime.

**GUIDES:** Heavy Duty 18-gauge galvanized guides fitted with dual polyethylene wear strips to reduce friction and noise. Guides are attached through the guide to the jamb without the need for clips welded to the back of the guide.

**FELT TAPES:** Prevents nesting and reduces paint rubbing.

**LIFT HANDLES AND STOP CLIPS:** Installed on exterior side of bottom bar and a non-rotting pull rope is attached to the inside angle.

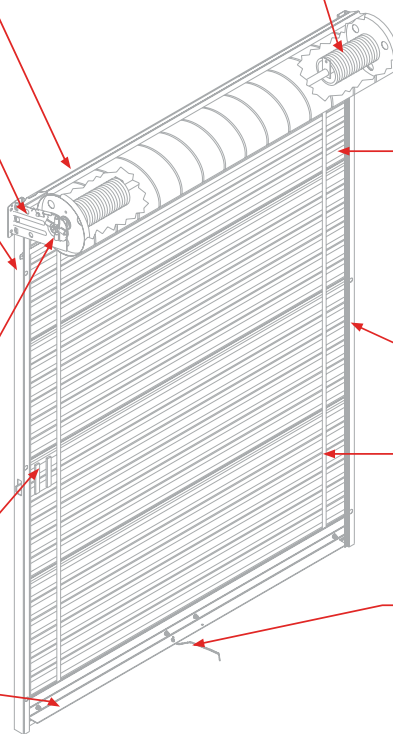

## MODEL 500 WARRANTY

BETCO's Model 500 door is manufactured with 26-gauge galvanized steel and covered by a 40-year crack, flake or peel paint warranty. Please refer to our website for specific details pertaining to our warranties.