

OPERATOR'S GUIDE



Orbitor

Pilling and Snagging Tester
Model 1516

Serial Numbers
1516/15/1001 and upwards

UniController

James Heal's
signature user interface

Extraordinary Testing Solutions

James H. Heal & Co. Ltd.

Halifax, England

Setting the Standard



Publication Orbitor 1516.docx

©2015

Published by:

JAMES H. HEAL & CO. LTD.
RICHMOND WORKS
HALIFAX
WEST YORKSHIRE HX3 6EP
ENGLAND

TELEPHONE +44 (0) 1422 366355

FACSIMILE +44 (0) 1422 352440

Email info@james-heal.co.uk

Internet <http://www.james-heal.co.uk>

TABLE OF CONTENTS

JAMES HEAL	5
Setting the Standard	5
Areas of Expertise	5
Introduction	6
Orbitor 1516 – Pilling and Snagging Tester	6
Key Features	6
Standards	6
Orbitor Standards Matrix	7
The Definition of Pilling	7
The Definition of Snagging	7
Scope	8
Principles of Pilling Tests	8
INSTALLATION	10
Health and Safety	10
Unpacking	10
Identification of Parts	11
Fuses	11
James Heal Service & Calibration	12
Unpacking check list	13
How to Order	13
GETTING STARTED	18
Connecting to Services	18
Mounting a Test Chamber	18
Initial Set-up of Test Chambers	19
Removing Test Chambers	19
Fitting/changing Snagging Points	19
Dressing a Moulded Polyurethane Pilling Tube using the Mounting Jig	20
Maintenance of Cork Liners	22
Maintenance of Specimen Tubes	22

UNICONTROLLER	23
Introduction	23
Using the UniController	24
The Push-Rotate (PR) Selector	24
Buttons	24
Options	24
Changing the Number of Cycles (Revolutions)	25
Changing the Rotational Speed	26
Changing Reversal Status	27
Changing the Volume	28
Changing the Language	28
Starting a Test	29
Overview of the UniController for Orbitor 1516	30
Technical Data	31
CE Conformity	31
Circuit Diagram	31
Revision History	32

JAMES HEAL

At James Heal, we are dedicated to designing and developing high precision testing instruments and test materials for physical and colour fastness testing. Our worldwide Service and Calibration division and expert technical assistance complement our product range, adding real value to your laboratory testing activities.

Setting the Standard

We are committed to forming close relationships and have established numerous partnerships within the textile industry, from trade and standards organizations, to test houses, customers and distribution partners.

With a heritage spanning more than 140 years, we have evolved and grown through a culture of continuous improvement, resulting in a thorough understanding of the applications, operating conditions and requirements of customers worldwide – from independent testing laboratories and test houses, to fabric suppliers, manufacturers and retailers.

Using knowledge and expertise, we consistently set the industry standard through product innovation and technology, with customer and user needs, present and future, driving our technological advancements. You can be assured that with James Heal, you will always receive the highest levels of product quality and customer service. We have Agents and Distribution partners all over the globe, ensuring locally available product whenever, and wherever you need it.

Areas of Expertise

Textile: Colour Fastness

- Chlorinated Water
- Dry Cleaning
- Dry Heat
- Hot Pressing
- Laundering
- Light
- Perspiration
- Phenolic Yellowing
- Print Durability
- Rubbing
- Washing
- Water

Textile: Physical Properties

- Abrasion
- Bursting Strength
- Compression and Puncture
- Crease and Wrinkle Recovery
- Crimp
- Drape
- Durability
- Flammability
- Mass per unit area
- Pilling and Fuzzing
- Security of Attachments
- Seam Slippage
- Shrinkage
- Snagging
- Spray Rating
- Stretch and Recovery
- Surface Deterioration
- Tear Strength
- Tensile Strength
- Washing and Drying

Non-Textile

- Bursting strength of nonwovens, plastics, paper and medical products
- Micro-scratching of laminates, wooden, painted, automotive and high gloss surfaces
- Physical and colour fastness testing of leather
- Rubbing fastness of laminates and wooden surfaces
- Tear strength of paper and plastics

INTRODUCTION

Orbitor 1516 – Pilling and Snagging Tester

The **Orbitor 1516** Series is the first Orbitor to be designed with James Heal's unique product signature and has been produced completely with the user in mind. We have combined James Heal's technical and performance expertise, with intuitive design and operation to produce the most ergonomic and user friendly Orbitor ever.

There are two standard instruments, one with 2-test positions and one with 4-test positions. To offer complete flexibility and choice, the two basic instruments can be fitted with any combination of the following test chambers:

- Pilling Box
- Snagging Box
- Pilling Drum
- Snagging Drum

For safety reasons, Orbitor features a common drive system, therefore it is not possible to run test chambers at different speeds simultaneously.

Key Features

- Preset counter for running in of new cork liners
- A brushless DC motor drives the test chambers, which ensures constant speed of rotation, the machine comes to a controlled stop automatically, when the pre-set counter has been reached.
- Three basic modes of rotation to cover the requirements of all existing standards: 60 rpm, 30 rpm and 30 rpm reversing after 50 revolutions.

Standards

Orbitor 1516 complies with the following standards:

Pilling

- EN ISO 12945-1
- TWC Test Method 152 (Formerly IWS)
- Marks & Spencer P18A
- Marks & Spencer P21A
- BS 5811 (withdrawn)

Snagging

- ICI Test Method 444
- Marks & Spencer P18B
- BS 8479 (with SnagPod)

Orbitor Standards Matrix

	Orbitor				Nu-Martindale		Impulse			Visual Assessment					
	PILLING		SNAGGING		Pilling Stations fitted	Abrasion Stations fitted	American Impeller	German Impeller	French Impeller	Pilling Assessment Viewer	Holograph plus IWS SM 54 Binary Photographs	Holograph plus Wovens and/or Knitted Hologram(s)	IWS Viewing Cabinet	ASTM Photographic Standards	Pillscope with Snagging Drum
	60rpm Pilling Box	30rpm Pilling Box	60rpm Snagging Box	30rpm reverse action drum with Snagging kit											
ASTM D 3512															
ASTM D 4970															
BS 5811 (withdrawn)															
DIN 53 867															
EN ISO 12945-1															
EN ISO 12945-2															
EN ISO 12945-3															
ICI Test Method 444															
IWS TM 152															
IWS TM 196															
M & S P18A															
M & S P18B															
M & S P21A															
NF G 07-121															
NF G 07-132															

The Definition of Pilling

Pilling is the formation of small balls of entangled fibres on the surface of the fabric. Such surface deterioration is generally unacceptable to the consumer. The amount of pilling that develops is governed by the rate of fibre entanglement, the rate of surface fibre development and the rate of fibre and pills wear-off. These rates depend on the fibre, yarn and fabric properties. Many pilling tests now include assessment of fabric fuzzing, which can be a precursor to pill formation.

The Definition of Snagging

Snagging is a term used to describe undesirable surface deterioration effects such as filamentation or looping. The breaking of individual threads in a woven or knitted fabric causes the generation of this type of surface damage. Here are some use terms used in snagging tests:

Snag – an undesirable loop on the surface of a woven or knitted fabric.

Protrusion – a partially formed snag.

Filamentation – fibrous or hairy appearance on the surface of a fabric due to broken yarn filaments.

Pulled Thread – a thread in a fabric that is tighter than adjacent threads.

Shiner – a thread that is more lustrous (and usually tighter) than adjacent threads.

Indentation – a concave distortion of the fabric surface.

Scope

Orbitor 1516 can be used to test both woven and knitted materials. It complies fully with the requirements of EN ISO 12945-1 'Textiles - Determination of fabric propensity to surface fuzzing and to pilling - Part 1: Pilling Box Method.'

In addition to Orbitor, **James Heal** offer Martindale and Impulse to fulfil the requirements of Part 2 and 3 of EN ISO 12945.

When fitted with Pilling Drums, **Orbitor 1516** complies with the requirements of Marks & Spencer P18A and P18B. An additional kit is available to convert the Pilling Drum to a Snagging Drum, compliant with Marks & Spencer P21A.

Principles of Pilling Tests

Four tubular specimens are mounted on polyurethane pilling tubes and tumbled in the cork-lined box for an agreed number of revolutions.

Specimens are usually prepared from samples which have been cleansed (wash or dry cleaned). Not only is this more representative of the fabric in use but it also helps to preserve the useful life of the cork liners.

Stringent quality control of the liners and the tubes is essential in order to ensure the critical demands of the standards are satisfied.

After tumbling, the change in surface appearance is visually assessed under controlled conditions; the Pilling Assessment Viewer (PAV), illustrated below, is available for this purpose. The primary descriptive method of assessment may be supported by photographic assessment.



The Pilling Assessment Viewer (PAV) used with EN ISO 12945-1 and -2.

Snagging differs from pilling by the inclusion of standard points fitted in either the Box or the Drum. Any tendency to form undesirable potential fabric deficiencies are highlighted as the tubular specimens randomly catches on the points.

ICI 444 modifies the cork lined box used for pilling tests by including one point in the centre of each of the six (6) sides of the box.

SnagPod, which is used for BS 8479, has four (4) rows of 20 angled pins spaced evenly inside the octagonal chamber. It is important to ensure the correct direction of the angled pins relative to the direction of rotation.



SnagPod: connected to Orbitor, pin bars specimens on tubes.

INSTALLATION

Health and Safety

- **Orbitor 1516** has a mass of approximately 35kg, therefore assistance from a colleague or suitable lifting apparatus is recommended.
- **Orbitor 1516** complies with the CE regulations in full, see page 31 for details.
- Ensure all test chambers are secure before commencing a test.
- Ensure all lids to the test chambers are securely closed and locked before commencing a test.
- Keep clear of all moving parts when the test chambers are rotating.
- A torque limiter causes the test chambers to stall if their rotation is impeded.
- Ensure the instrument is isolated from the electrical supply before removing any covers. Covers should only be removed by a qualified Engineer or Electrician.

• NEVER operate Orbitor 1516 with any of the covers removed.

- Fuse with the correct amperage rating must be used.
- Never use **Orbitor 1516** for anything other than what it is designed for.
- For Care and Maintenance requirements please refer to the appropriate section of this Operator's Guide.

Unpacking

- Remove the tape from the packing case lid and open.
- Carefully remove the packaging and contents from the packing case. Note that any accessories ordered with the instrument are packed with the instrument.
- Remove the sleeve and then very carefully lift the instrument and place it on a firm flat surface.
- Do not dispose of any packaging material until all standard and optional accessories ordered are fully accounted for. If there are any discrepancies, please contact your supplier immediately.

Identification of Parts

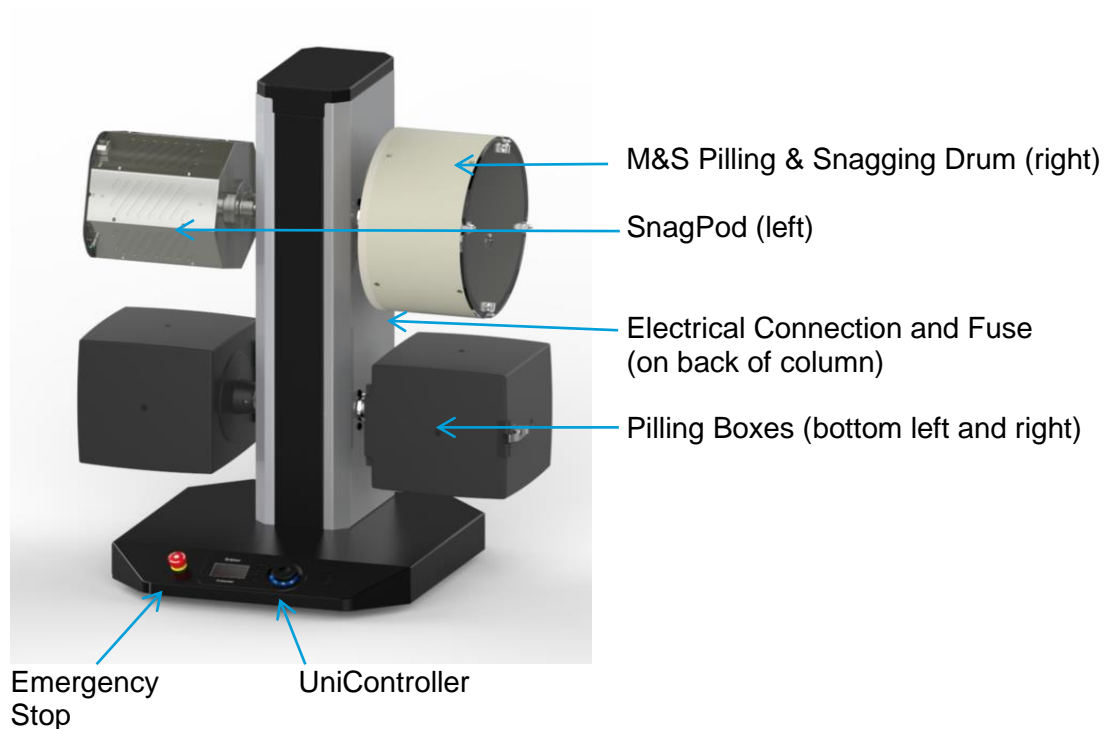

Fuses

- One fuse is fitted, located at the back of the instrument, below the mains lead socket.
- The 1A anti-surge fuse protects the complete machine including the motor and drive.
- To replace a fuse, first isolate [Orbitor 1516](#) from the mains supply. Place a screw driver blade in the slot of the fuse holder, then press and turn anti-clockwise approximately 1/4 of a turn. The fuse holder complete with fuse is now released.
- The Power rating for [Orbitor 1516](#) is 40 Watts.

James Heal Service & Calibration

James Heal Service & Calibration is a totally comprehensive, worldwide support programme. When you buy instrumentation from us, it is the beginning rather than the end of an association.

Our aim is simple:

To provide precisely the services you need to maintain and protect the value of your investment.

For any enquires you may have regarding your instrument please contact James Heal Service & Calibration by email, phone or fax.

In all communications please quote the serial number of your instrument and the software version number, e.g., 1516/15/1001 and V1.00.

James Heal Service & Calibration contact details:

Email	support@james-heal.co.uk
Telephone	+44 (0) 1422 366355
Fax	+44 (0) 1422 352440

Unpacking check list

- Please check the instrument serial number plate corresponds with your delivery note. The serial number plate is located on the side of the instrument.
- The following standard accessories are included with each instrument, either 2 position or 4 position.

142-326	Mains Lead Set – Angled
381-413	Allen Key 4mm AF
794-521	Specimen Mounting Jig
297-032	Operator's Guide on CD

Test Chambers and Test Templates must be ordered separately – please see: How to Order below for a full list of Optional Accessories.

How to Order

Recommended Starting Kits (pilling only - EN ISO 12945-1)

901-476	1 x Orbitor Model 1516 -2 85 – 264 VAC 50/60 Hz
794-753	2 x Cork-Lined Plastic Pilling Boxes
772-101	1 x Pilling Box/Drum Test Template
794-752	2 x Packs (6) Cork Liners
789-511	1 x Pack (10) Rolls 19mm wide PVC Tape (colour: white)
708-925	1 x VeriVide Pilling Assessment Viewer 230V 50/60Hz
202-516	1 x UKAS Certificate of Calibration for Orbitor
901-477	1 x Orbitor Model 1516/4 85 – 264 VAC 50/60 Hz
794-753	4 x Cork-Lined Plastic Pilling Boxes
772-101	1 x Pilling Box/Drum Test Template
794-752	4 x Packs (6) Cork Liners
789-511	2 x Packs (10) Rolls 19mm wide PVC Tape (colour: white)
708-925	1 x VeriVide Pilling Assessment Viewer 230V 50/60Hz
202-516	1 x UKAS Certificate of Calibration for Orbitor

Recommended Starting Kits (pilling only - M & S P18A)

901-476	1 x Orbitor Model 1516 -2 85 – 264 VAC 50/60 Hz
788-741	2 x Drums
772-101	1 x Pilling Box/Drum Test Template
788-742	1 x Pack (5) Liner Supports
789-513	1 x Pack (10) Double-sided Adhesive Tape
708-917	1 x Holoscope 230V 50/60Hz
708-915	1 x Knitted Hologram
708-914	1 x Woven Hologram
202-516	1 x UKAS Certificate of Calibration for Orbitor
901-477	1 x Orbitor Model 1516/4 85 – 264 VAC 50/60 Hz
788-741	4 x Drums
772-101	1 x Pilling Box/Drum Test Template
788-742	2 x Packs (5) Liner Supports
789-513	2 x Packs (10) Double-sided Adhesive Tape
708-917	1 x Holoscope 230V 50/60Hz
708-915	1 x Knitted Hologram
708-914	1 x Woven Hologram
202-516	1 x UKAS Certificate of Calibration for Orbitor

Recommended Starting Kits (pilling only - M & S P18B)

901-476 1 x **Orbitor Model 1516 -2** 85 – 264 VAC 50/60 Hz
788-741 2 x Drums
772-101 1 x Pilling Box/Drum Test Template
788-742 1 x Pack (5) Liner Supports
789-513 1 x Pack (10) Double-sided Adhesive Tape
708-917 1 x Holscope 230V 50/60Hz
766-460 1 x IWS Pilling Photographs SM54 for knitted fabrics
202-516 1 x UKAS Certificate of Calibration for Orbitor

901-477 1 x **Orbitor Model 1516/4** 85 – 264 VAC 50/60 Hz
788-741 4 x Drums
772-101 1 x Pilling Box/Drum Test Template
788-742 2 x Packs (5) Liner Supports
789-513 2 x Packs (10) Double-sided Adhesive Tape
708-917 1 x Holscope 230V 50/60Hz
766-460 1 x IWS Pilling Photographs SM54 for knitted fabrics
202-516 1 x UKAS Certificate of Calibration for Orbitor

901-476 1 x **Orbitor Model 1516 -2** 85 – 264 VAC 50/60 Hz
2-Position Instrument
Standard accessory:
1 x Specimen Mounting Jig 794-521

Test Chambers, Test Templates and SnagPod must be ordered separately

901-477 1 x **Orbitor Model 1316/4** 230V/110V (Switchable voltage, frequency independent)
4-Position Instrument
Standard accessory:
1 x Specimen Mounting Jig 794-521

Test Chambers, Test Templates and SnagPod must be ordered separately

Test Chambers

794-753 Cork-Lined Plastic Pilling Box
Standard accessories:
1 pack of 4 Moulded Polyurethane Pilling Tubes (140.25mm long) 758-555
1 x Roll 19 mm wide PVC Tape 789-511 (colour: white)

794-754 **Cork-Lined Plastic Snagging Box**
Standard accessories:
6 x Snagging Pins (fitted) 511-545
1 pack of 4 Moulded Polyurethane Pilling Tubes (140.25mm long) 758-555
1 x Roll 19 mm wide PVC Tape 789-511 (colour: white)

788-741 **Pilling Drum**
Standard accessories:
3 x Packs (4) Moulded Polyurethane Pilling Tubes (70.2mm long) 758-551
1 x Ramp 788-743
1 x Liner Support 788-742
1 x Pack (20) Locking Rings 758-553
1 x Roll Double-sided Adhesive Tape 789-513

794-523 **Snagging Kit for Pilling Drum**
Comprising:
3 x Pinned Bars 789-361
2 x Bead Bags 785-251

794-726 **SnagPod (BS 8479:2008 & BHS TM46)**
Standard accessories:
2 x Packs (4) Felt-covered Polyurethane Tubes 758-554
1 x Pack (20) Locking Rings 758-553
1 x Specimen Template 772-121
1 x Pack (10) Fixing Screws for Snagging Bars 319-152
1 x Assessment Mask 766-480

201-933 *ISO Certificate of Calibration for SnagPod*

Assessment (SnagPod)

708-925 **VeriVide Pilling Assessment Viewer 220/230V 50/60Hz**
708-930 **VeriVide Pilling Assessment Viewer 110V 50/60Hz**
766-455 **1 x Set (9) SnagPod Reference Photographs**

Spares and Consumables (SnagPod)

794-824 **Snagging Bar (Pack of 4)**
319-152 **Fixing Screws for Snagging Bars** - per pack (10)
758-554 **Felt-covered Polyurethane Tubes** - per pack (4)
758-553 **Pack (20) Locking Rings** - per pack (20)
766-455 **SnagPod Reference Photographs** - per set (9)
772-121 **Specimen Template**
766-480 **Assessment Mask**

Test Templates

772-101 **Pilling Box/Drum Test Template**
772-102 **Snagging Box Test Template**
772-107 **Snagging Drum Test Template**

Spares for Pilling or Snagging Boxes

794-753 **Cork Liners for Pilling Boxes (mounted on steel plates)** - per set (6)
794-746 **Cork Liners for Snagging Boxes (mounted on steel plates)** - per set (6)
794-521 **Specimen Mounting Jig (Stand, Tube and Plug)**
758-555 **Moulded Polyurethane Pilling Tube (140.25mm long)** - per pack (4)
789-511 **Rolls of 19 mm wide PVC Tape (colour: white)** - per pack (10)
511-545 **Snagging Points for one Plastic Pilling Box** - per set (6)

If snagging parts are purchased to convert a box from pilling to snagging, a set of Cork Liners 794-746 should also be ordered.

Spares for Pilling Drum

788-743 **Ramp** - each
788-742 **Liner Supports** - per pack (5)
758-551 **Polyurethane Pilling Tubes (70.2mm long)** - per pack (4)
758-553 **Locking Rings** - per pack (20)
789-513 **Double-sided Adhesive Tape (approx. 25 mm wide x 36 yd long)** - per pack (10 rolls)

Spares for Snagging Kit for Pilling Drum

785-251 **Bead Bag** - each
789-361 **Pinned Bars** - each

2-year Spares Kit (Orbitor)

- 117-488* **Controller**
- Calibration**
- 202-516 *UKAS Certificate of Calibration for Orbitor*
- Assessment**
- 708-925 **VeriVide Pilling Assessment Viewer** 230V 50/60Hz
- 708-930 **VeriVide Pilling Assessment Viewer** 110V 50/60Hz

The VeriVide Pilling Assessment Viewer complies with the following standards:
 EN ISO 12945-1 = Orbitor
 EN ISO 12945-2 = Nu-Martindale/Mini-Martindale
 ASTM D 3514

- 708-949 **Spare Lamp D65 8W 300 mm for VeriVide Pilling Viewer**
- 708-908 **PilliScope (no drums)** 230V 50/60Hz
- 708-919 **PilliScope (no drums)** 110V 50/60Hz
- 708-966 **Spare Lamp 20W for PilliScope**
- 708-909 **Snagging Drum for PilliScope (P21A)**
- 708-917 **Holoscope (no holograms)** 230V 50/60Hz
- 708-918 **Holoscope (no holograms)** 110V 50/60Hz
- 708-916 **Spare Lamp 20W for Holoscope**
- 708-915 **Knitted Hologram (P18A)**
- 708-914 **Woven Hologram (P18A)**
- 766-460 **IWS Pilling Photographs SM 54 for knitted fabrics (P18B)**

M & S P18B : Holoscope (without holograms) plus IWS SM54 photographs.

SPARES FOR EARLIER MACHINES

Summary

Box Type	Cork Liner for Pilling	Cork Liner for Snagging	Snagging Points (set of 6)
Plastic Moulded (Black)	794-752	794-746	511-545
Metal Fabricated (Silver)	794-752	794-746	794-747
Plastic Moulded (Blue)	794-722	794-727	511-545
Plastic Fabricated (Grey)	794-722	794-727	396-754
Wood	393-501	393-501	794-522

Spares for earlier machines with (silver or blue) fabricated metal boxes

- 794-752 **Cork Liners for Pilling Boxes (mounted on steel plates)** - per set (6)
- 794-746 **Cork Liners for Snagging Boxes (mounted on steel plates)** - per set (6)
- 794-747 **Snagging Points for one Metal Pilling Box** - per set (6)

Spares for earlier machines with (blue) moulded plastic boxes

- 794-722 **Cork Liners for Pilling Boxes (mounted on aluminium plates)** - per pack (6)
- 794-727 **Cork Liners for Snagging Boxes (mounted on aluminium plates)** - per set (6)
- 511-545 **Snagging Points for one box** - per set (6)

Spares for earlier machines with (grey) fabricated plastic boxes

- 794-722 **Cork Liners for Pilling or Snagging Boxes (mounted on aluminium plates)** - per pack (6)
- 794-727 **Cork Liners for Snagging Boxes (mounted on aluminium plates)** - per set (6)
- 396-754 **Snagging Points for one box** - per set (6)

Spares for earlier machines with wood boxes

- 393-501 **Cork Liners for Pilling or Snagging Boxes** - per pack (6)
- 794-522 **Snagging Points and Mountings for one box** - per set (6)

GETTING STARTED

Connecting to Services

Stand the **Orbitor 1516** on a firm, level surface.

Connect the **Orbitor 1516** to the electricity supply using the appropriate electrical lead supplied.

Mounting a Test Chamber

Extract the locking screws (2 per box) using the 4 mm ball driver provided.



The locking screws can be found on the circular hub.

Align the test chamber with the drive shaft, ensuring the locking screws are aligned with the dimples on the shaft.

Gently slide the test chamber onto the shaft ensuring the mounting hub is fully engaged.

Tighten both locking screws using reasonable force. It is important that the locking screws are fully engaged in the dimples on the drive shaft.

After several hundred revolutions the test chamber may self-align causing the locking screws to become loose. At a convenient time, re-tighten the locking screws.

Periodically check the screws are tight.

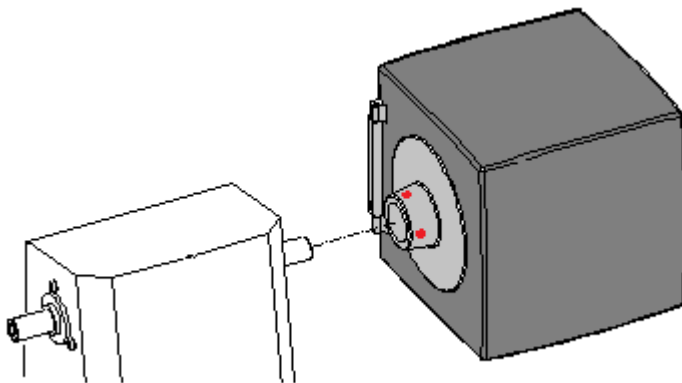

NEVER lift the machine by the test chambers. This will result in damage to the instrument.

Initial Set-up of Test Chambers

New cork-lined boxes should be run-in for approximately 200 hours with 4 blank tubes until the linings have stopped shedding cork dust. All cork dust must be carefully brushed out and removed. This procedure must be repeated each time the cork liners are replaced.

DO NOT inhale the cork dust.

Please refer to the Marks & Spencer test method for instructions on how to use the Marks & Spencer drum liner, support, ramp, and the fitting of snagging points to the drum.

Removing Test Chambers

Test Chambers can be removed simply by fully unscrewing the locking screws using the 4mm hexagon key / ball driver. When the screws are fully retracted, carefully slide the box off the end of the drive shaft. Ensure both drive shaft and mounting flange are clean before reassembly.

Fitting/changing Snagging Points

James Heal supply the 'Cork-Lined Moulded Pilling Box' fitted with snagging points, however as the snagging points become less sharp with use then it will become necessary to replace them as follows:

- Remove cork liners from the boxes.
- The cork liner plates have a 6 mm hole in the centre.
- Drill a 6mm hole through cork, while supporting underneath to prevent cork damage.
- Insert one snagging point through the 6mm hole/slot in each cork liner plate.
- The plastic moulded box accommodates six (6) snagging points.
- The head of each snagging point should locate in either a slot or hole in the box.
- Reassemble the six plates, bottom plate first. Replace each plate firm against the side of the box.

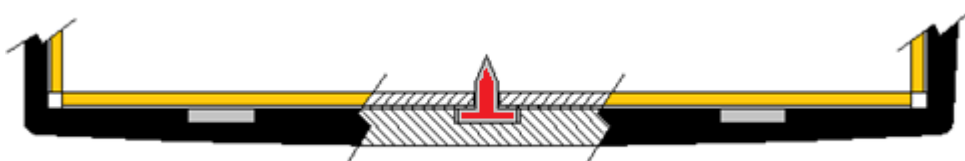

Dressing a Moulded Polyurethane Pilling Tube using the Mounting Jig

Once the required number of samples have been conditioned according to the test method, and laundered if necessary, cut and sew the specimens carefully following the test method instructions.

- Turn each specimen inside-out so that the face of the fabric forms the outside of the tube.
- Cut 12mm from one end of the fabric tube.
- Take a moulded polyurethane pilling tube place over rod A of the mounting jig, pull the tube round rod B. Push a hollow metal cylinder fitted with a tapered end plug, over the folded pilling tube.
- Slide the tubular specimen over the tapered end plug and metal cylinder.
- Grip the fabric against the rubber tube and then carefully remove the metal cylinder leaving the fabric on the rubber tube.
- To prevent fraying, cover the cut ends of the specimen with self-adhesive PVC tape (789-511) around the tube, leaving 6 mm of each end of the tube exposed.
- Once testing is complete, remove the specimens from the pilling tubes, using a “stitch unpick” (Singer seam ripper) taking special care not to touch and damage the pilling tubes.

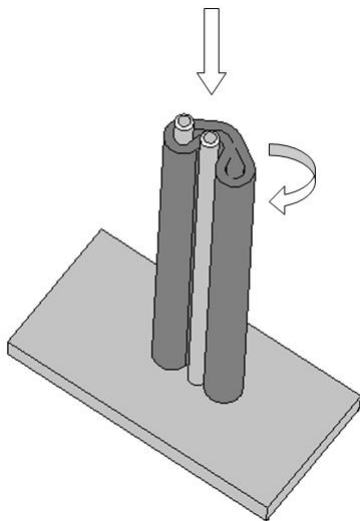

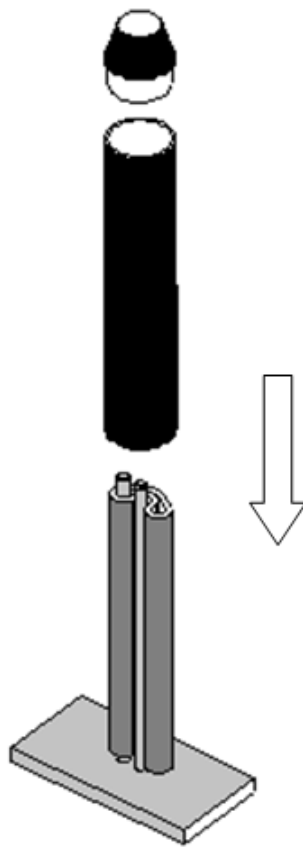

Maintenance of Cork Liners

Before each test, it is essential to ensure that all fluff and other debris is removed from inside the test chambers, e.g. by means of a vacuum cleaning device or by using a small brush.

Periodically, it is necessary to clean the cork liners when they have become contaminated by any residue from the test specimens. A suitable cleaning solvent is industrial methylated spirit (IMS).

Note - the use of methylated spirit and other solvents may be the subject of national legal regulations for health & safety and/or environmental reasons.

Cork linings should be inspected at regular intervals and replaced when obviously “polished”, damaged or soiled in such a way as to modify their frictional properties.

Maintenance of Specimen Tubes

The specimen tubes should be inspected at regular intervals in accordance with the test method specification being used, and replaced as necessary.

The specimen tubes (polyurethane, press-moulded tubes) should be virtually identical to each other when new. Experience of intensive use has shown that no significant wear of these tubes occurs under normal use conditions.

The most critical part of the tube is the convex outer surface at its end. New tubes should be checked on receipt to ensure that no moulding faults (e.g., flashing) have occurred in the critical region. In use, damage is unlikely; however if change should occur it is essential that the tube be replaced.

Over time, the specimen tubes will age. This will become evident if the specimen tube becomes hard and showing cracks on the ends of the tubes. If this occurs then replace the tubes.

UNICONTROLLER

Introduction

The UniController is our all new, signature user interface. The UniController brings new levels of ease of use and functionality. Elegantly designed, the UniController will reduce training times and can be used by all levels of Operator.

Amongst its many features are:

- Fast, easy editing of cycle and speed settings.
- Close, accurate control of speed and cycle counting.
- Display of current rotational speed.
- IP 64 Rated to ensure waterproofness



The James Heal UniController consists of

- LCD Display
- 2 selection buttons
- Push-Rotate Selector

The UniController allows the user to control all aspects of the test in a simple and intuitive way.

The display shows the user the defined test parameters; once the test begins it will show the live test information for cycles remaining and actual rotational speed.

For the purposes of this Operators Guide, the top selection button will be called 'Button 1' and the bottom selection button will be called button 2.

The function(s) displayed next to Button 1 and Button 2 will change depending on the circumstances and function being carried out.

Using the UniController

When [Orbitor 1516](#) is initially powered up, the James Heal icon will be briefly displayed followed by a brief display of the Firmware version number. These are only displayed when the unit is powered up.

The Push-Rotate (PR) Selector

The Push-Rotate (PR) Selector has two main modes of operation:

- **Push** to Start, Select or Enter
- **Rotate** to cycle through the options.

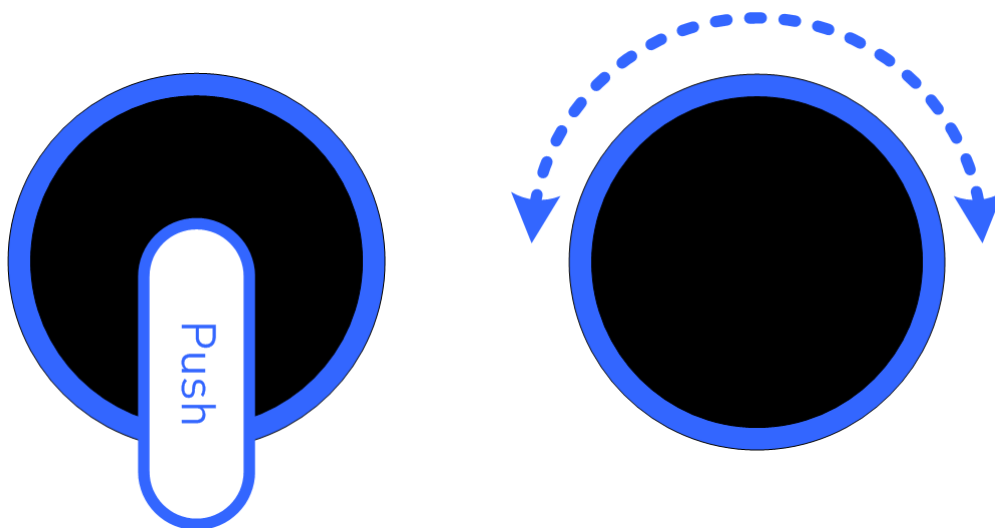

At the end of a test, the blue LED illumination will pulse on and off to indicate the [Orbitor 1516](#) requires attention from the Operator.

Buttons

The function of the Button 1 and Button 2 can change throughout the testing process.

Options

Using the [UniController](#) for [Orbitor 1516](#) you can set or change the following:

- Number of cycles (revolutions)
- Speed (rpm)
- Reversal (on/off)
- Volume
- Language for [UniController](#) user interface

Changing the Number of Cycles (Revolutions)



While **Orbitor 1516** is not running, turn the PR selector clockwise.



The display changes.

Push the PR Selector to move to Edit mode.

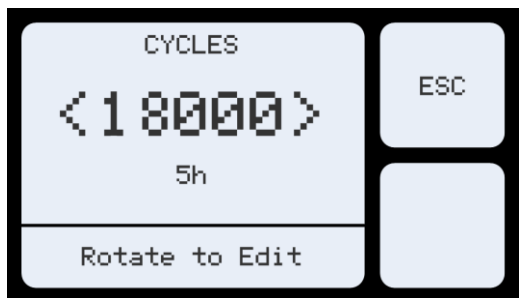

Rotate the PR Selector to change the number of cycles (revolutions) required.

Rotate clockwise to increase and counter clockwise to decrease.



When the correct number of cycles (revolutions) is displayed, push the PR Selector to Enter the new value.

Changing the Rotational Speed

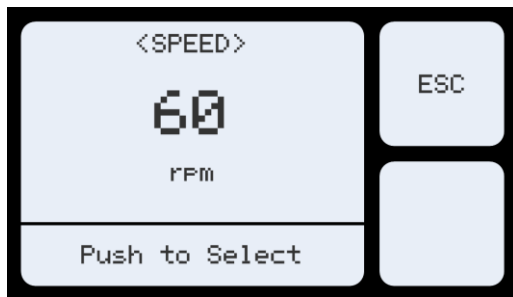

Orbitor 1516 is capable of operating in several different speed modes, either 60rpm, 30rpm or 30rpm Reversing with a direction change after every 50 cycles (revolutions).

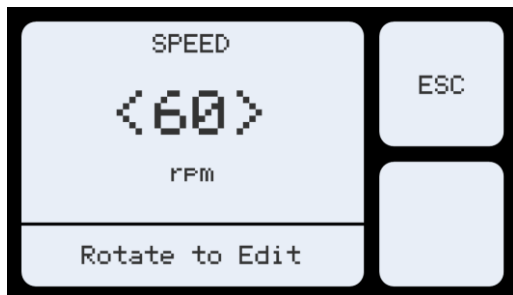

Rotate the PR Selector to change the Speed required.

Rotate clockwise to increase and counter clockwise to decrease.

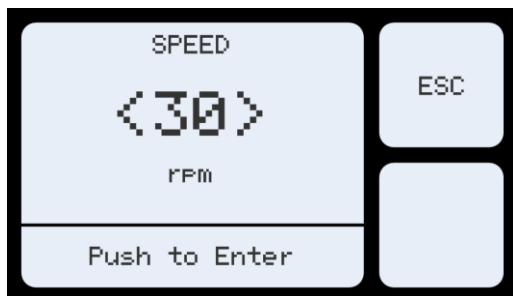

When the correct Speed is displayed, push the PR Selector to Enter the new value.

Changing Reversal Status



Some standards require the box or drum to alternate the direction of rotation.



Rotate the PR Selector to change the Reversal status to ON or OFF.



When the correct Reversal status is displayed, push the PR Selector to Enter the new value.

The value <50> indicates the direction of rotation will change after every 50 cycles (revolutions).

Changing the Volume

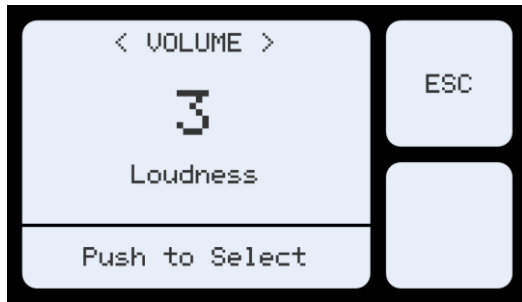

Changes the Volume (Loudness) of the sound from the speaker.

Note: To make this selection, you must turn the PR Selector in the first 30 seconds after powering up the [Orbitor 1516](#) in order to access this setting.

Changing the Language



Changes the Language of the UniController user interface.

Note: To make this selection, you must turn the PR Selector in the first 30 seconds after powering up the [Orbitor 1516](#) in order to access this setting.

Starting a Test

Set the number of Cycles required
Set the Speed required
Switch on Reversal if required

Note: these values remain stored for subsequent tests.

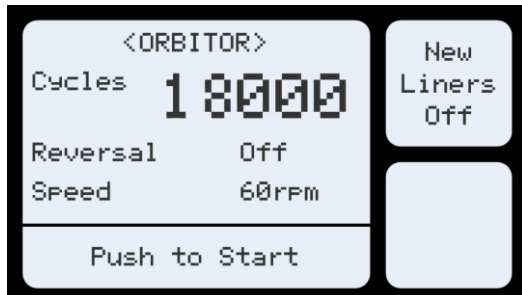

Push the PR Selector to Start the test.

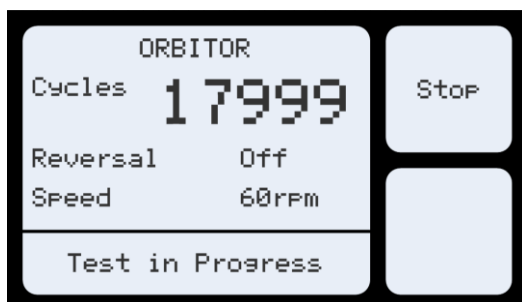

The counter will count-down to zero.



At the end of a test, the blue LED illumination will pulse on and off to indicate the [Orbitor 1516](#) requires attention from the Operator.

Overview of the UniController for Orbitor 1516

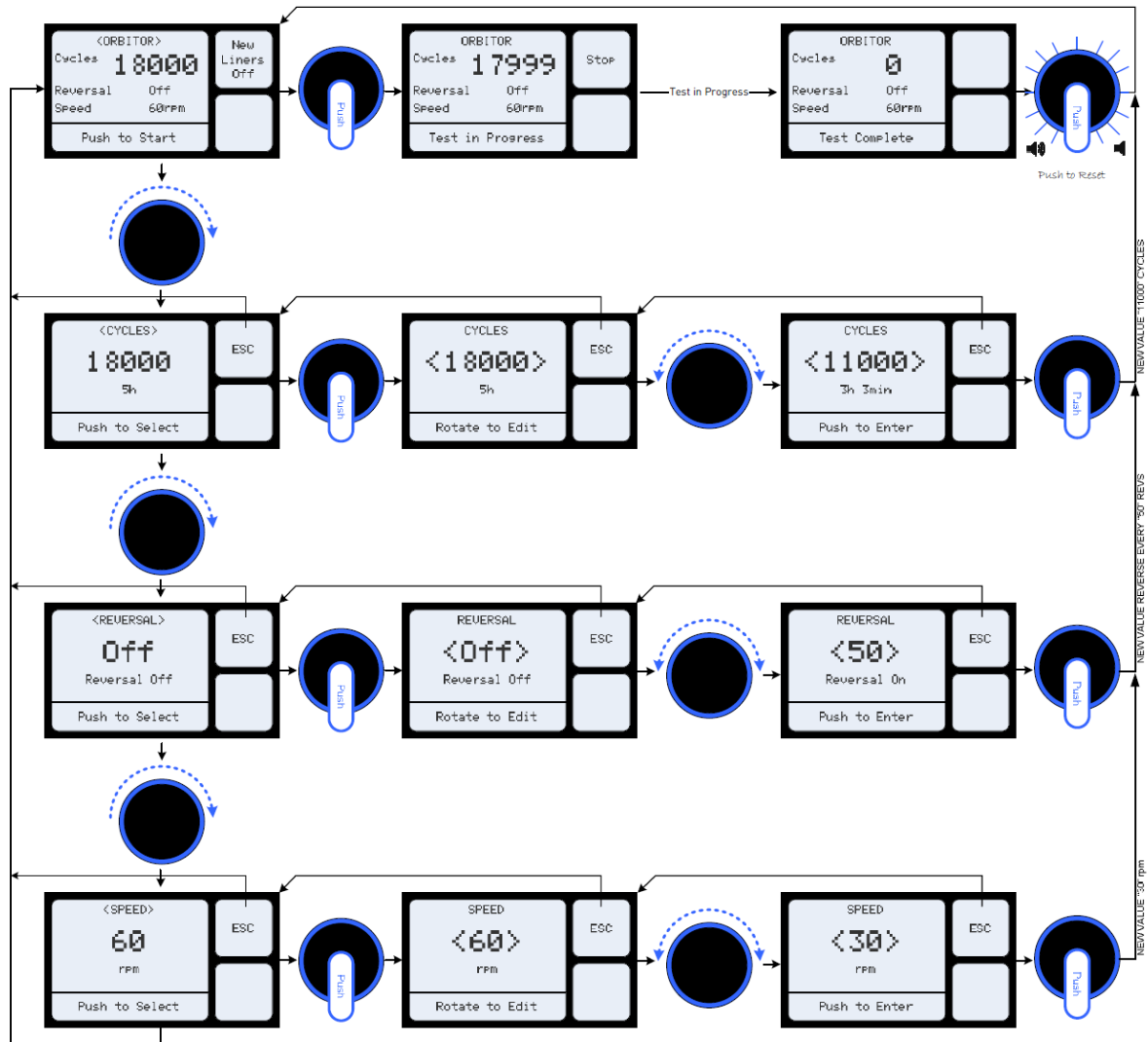

TECHNICAL DATA

CE Conformity

Orbitor 1516 is CE marked and complies with the following directives:

- Machinery Directive 2006/42/EC
- Low Voltage Directive 2006/95/EC
- EMC Directive 2004/108/EC
- WEEE Directive 2002/96/EC
- RoHS Directive 2002/95/EC

Circuit Diagram

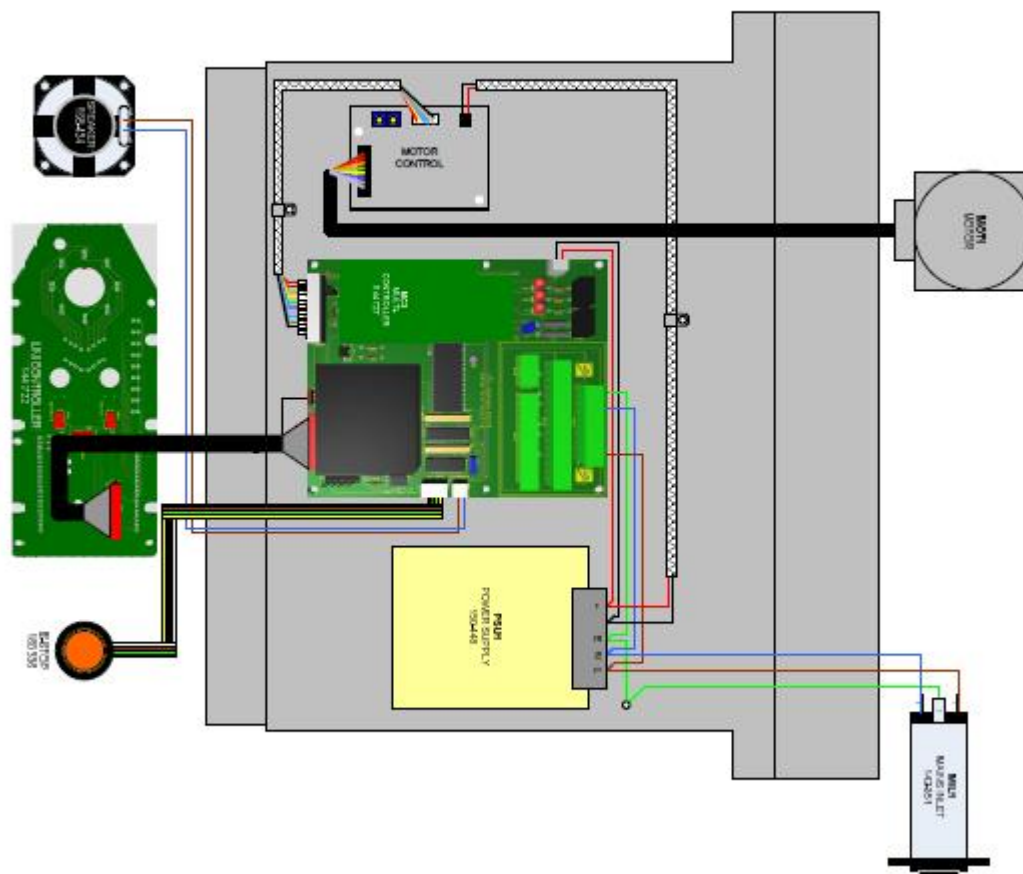

REVISION HISTORY

See front cover for Publication number, e.g., 290-1516-1

Rev	Date	Originator	Details of revision
A	22/04/15	LW	First release