

PLASTIC STRAPPING SYSTEMS
MODEL SERIES: CYKLOP CI 70



The automatic strapper Cyklop CI 70 is suitable for strapping packages, mail-boxes or other products such as printed matter. This machine can be used in various industries. The Cyklop CI 70 strapper is a reliable machine with low maintenance requirements but simple to operate.

Basic features:

Automatic strap feed

The strap from the coil dispenser is placed between the guiding rolls. After activating the start button the strap is fed automatically. The strap reservoir is filled up and the machine is ready to start.

Loop function

Strap cycles having been initiated by error will not cause any problem. The strap is ejected and the next cycle can start again without any trouble.

Strap end sensor

Coil end is detected by a sensor. Remaining strap within the machine will be automatically ejected and the machine is ready for coil change.

Modular strap track system

Modular arch segments made from aluminium.

Strap tension

Pre-selection per potentiometer, continuously variable.

Working height

The working height amounts to 810 mm. 4 castors, 2 of them with locking device.

Operation

Strap cycle can be started either via push button, foot-pedal or separately by switch on table sensor. When a package / bundle is placed into the machine area, the strap cycle starts automatically.

Variable seal time

Pop open of seals on critical products is now history. Selective timing for increased seal efficiency is possible via a switch.

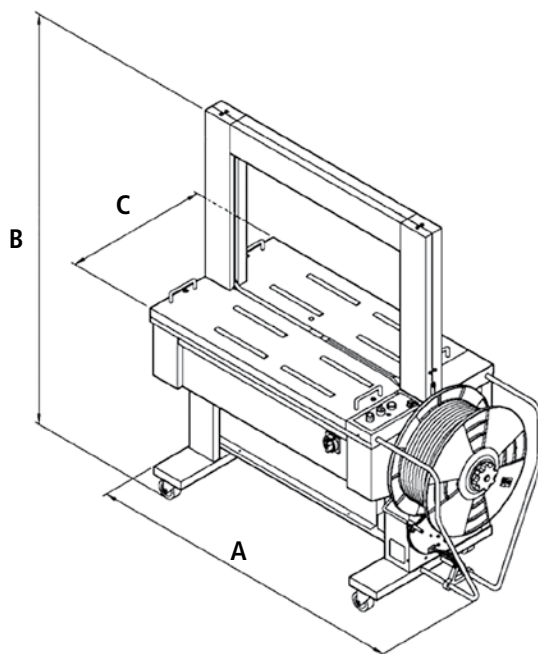

Frame sizes	A	B	C
650 x 600	1430	1540	620
850 x 600	1430	1540	620
850 x 800	1430	1740	620
1250 x 800	1830	1740	620

Technical data:

Capacity, straps/min up to 29 strpa/min at frame size 650 x 600 mm depending on the pre-selected strapping tension and package size.

Package weight max. 100 kg
 Strap tension stepless adjustable
 Strap Polystrap 9 or 12 mm
 Sealing method Heat seal
 Total weight approx. 220 kg
 Min. package size 130 x 20 mm (W x H)

Power supply 230 V, 50 Hz, 1 Ph.
 Total connected load approx. 1,0 kW
 Range of temperature +5 °C to +40 °C
 Noise level approx. 83 dB(A)

Frame sizes available (WxH)

- 650 mm x 600 mm
- 850 mm x 600 mm
- 850 mm x 800 mm
- 1250 mm x 800 mm

Strap coil:
 Inner diameter 200 mm
 Outer diameter 420 mm
 Coil width 190 mm

Standard equipment:

- Table release connectable
- Prolonging holding time connectable
- Foot switch

Subject to Modification. © Cyklop GmbH, Cologne, Protective notice pursuant to ISO 16016 to be observed. 02.2014

WWW.CYKLOP.COM

DIRECT LINE: +49 (0) 2236 602 0

CYKLOP GmbH
 Industriestraße 133
 50996 Cologne
 Germany
 info@cyklop.de

