

# Whiz

## Notification Pager Manual

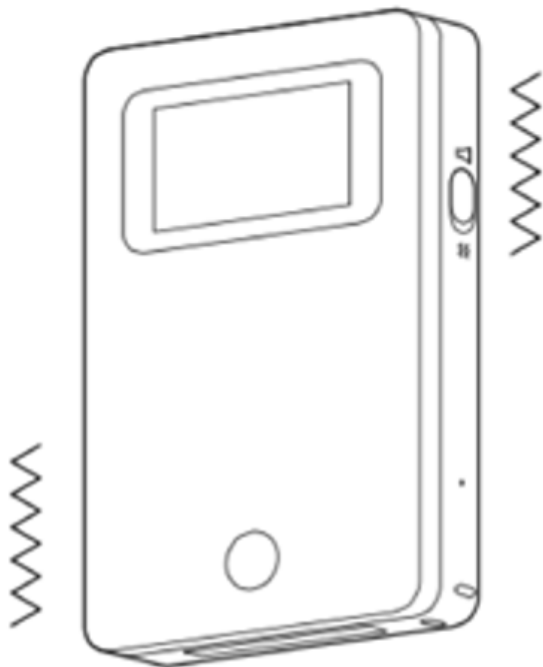

**CAUTION:** Read the Notification Pager Manual (this document) before using the product, and store in a safe location after reading it.

# 1. Notification Pager

## 1-1. Notification Pager Functions

Notification pager will notify the operator (Sound/Vibration) when irregular occur during autonomous cleaning or when the machine encounters obstacles. When using the notification pager for the first time, please take the pager out of the battery box and charge the pager. (see "Recharging the Notification Pager").

- Notification pager can only be used during autonomous cleaning.

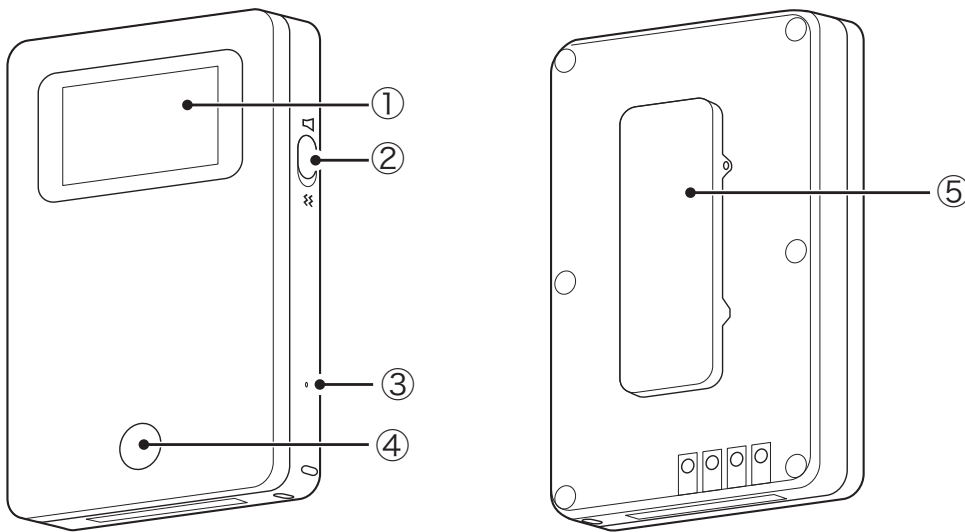

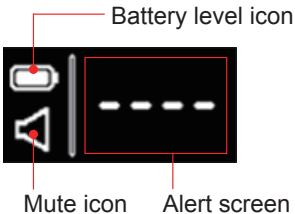
No.	Name	Description
①	Display	<p>The battery level icon and mute icon appear at the left of the display, and alerts appear at the right of the display. (see P80 "11-1-2 Alert Display and its Notification Timing")</p>  <p>Battery level icon</p> <p>Mute icon    Alert screen</p>
②	Pager mute switch	To set the notification pager only to vibrate for alert notifications, set the pager mute switch on.
③	Power button	Use the given pin to turn the power On for the Notification Pager.
④	Pager main button	To stop the alert and vibration, press the pager main button.
⑤	Clip	Use the clip when placing the notification pager in your pocket, etc.





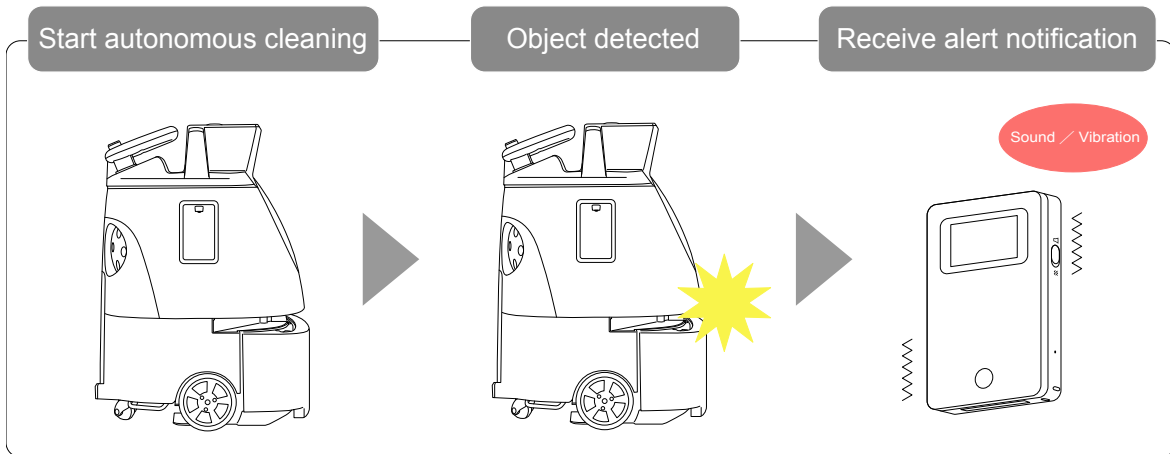



## 1-1-1.Notification Pager Functions & Usage

- When the machine detects danger or detects an obstacle, an alert will be displayed on the notification pager (see "Alert display and its notification timing") and it notifies the operator by emitting an alert and vibrating. It emits an alert and vibrates for 15 seconds then stops for 5 seconds, which it repeats for 10 minutes. After the error with the machine has been resolved, the notification pager sounds for 1 second and its display indicates standby.
- To receive alert notifications, pair the machine and the notification pager. (see "Pairing the Notification Pager") Once the display on the notification pager indicates communication, place it in the pager compartment to complete pairing.



- During autonomous cleaning, always carry the notification pager on you. Alerts cannot be received while the notification pager is in the pager holder.
- The range in which the notification pager can communicate with the machine is a direct line up to 300 m (985 ft) (2 floors above and below).
  - \* Range of communication depends on the environment. Communication may not be possible such as where there are walls with metal.
- After using the notification pager, place it in the notification pager charger (see "Recharging the Notification Pager").
- If the notification pager won't be used for a long period of time (approx. 2 months) turn the switch Off (see "Turning the Notification Pager On/Off")

## 1-1-2.Alert display and its notification timing

Appearing on display	Description	Appearing on display	Description
	Standby (within the communication range/ paired)		Autonomous cleaning complete
	Machine battery level low		No machine battery remaining
	Dustbag full		Connected for wireless communication
	Connection for wireless communication not possible (outside communication range/not paired)		<p>Error alert</p> <ul style="list-style-type: none"> <li>• When danger has been detected near obstacles or steps</li> <li>• When the emergency stop button has been pressed</li> <li>• When the machine goes off path during the operation</li> </ul>

## 1-2. Turning the Notification Pager On/Off

When using the notification pager for the first time, use the supplied pin to turn the power On.

### 1-2-1. Turning the Notification Pager On

- 1 Insert the supplied pin in the power button on the side of the notification pager.

Keep the inserted pin pressed until the notification pager vibrates.

 An icon appears on the display.

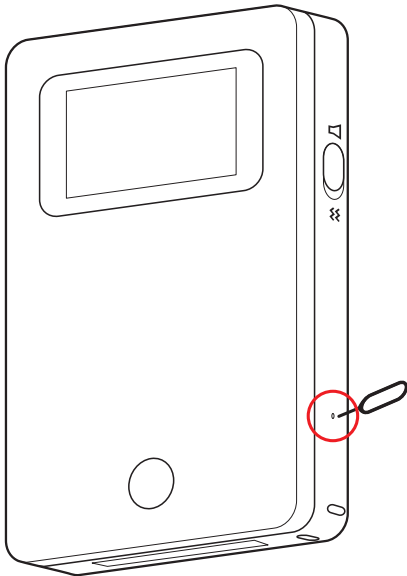

## 1-2-2.Turning the Notification Pager Off

**1** Insert the supplied pin in the power button on the side of the notification pager.

---

 The display turns off.

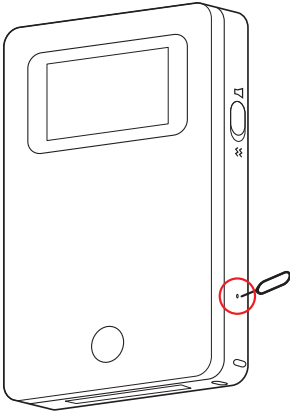

**2** Press the pager main button, and check that nothing appears on the display.

---

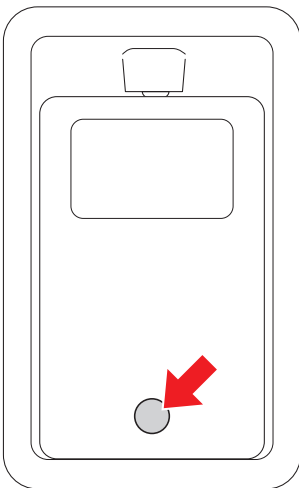

## 1-3. Pairing the Notification Pager

In order to receive the alert on the notification pager, the pager must be paired with the machine itself.

- 1 Turn On the notification pager and the machine.

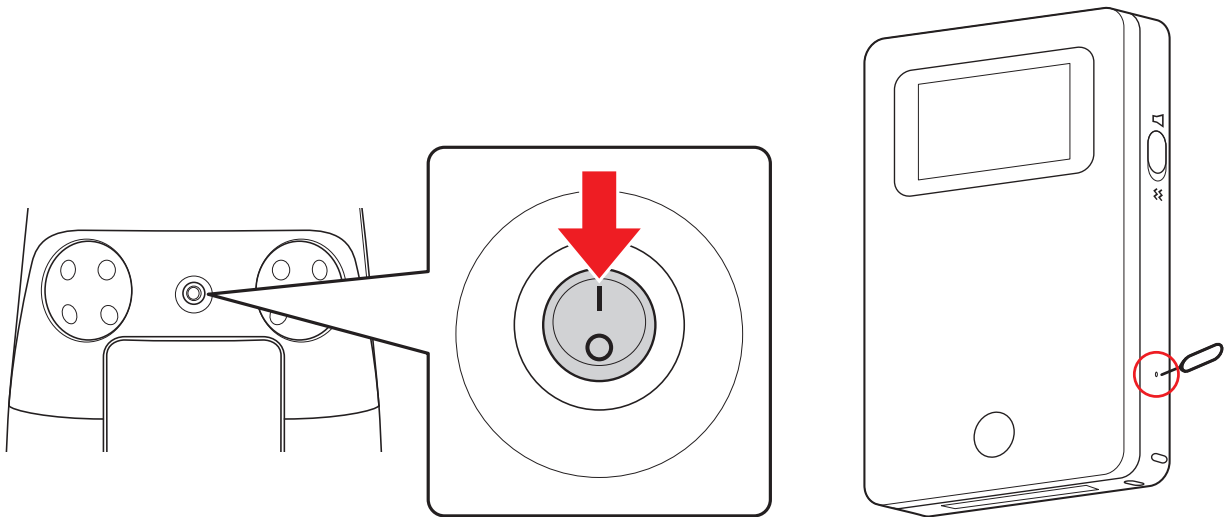

- 2 Check if the machine is connected to the Robot Operations Center (ROC).

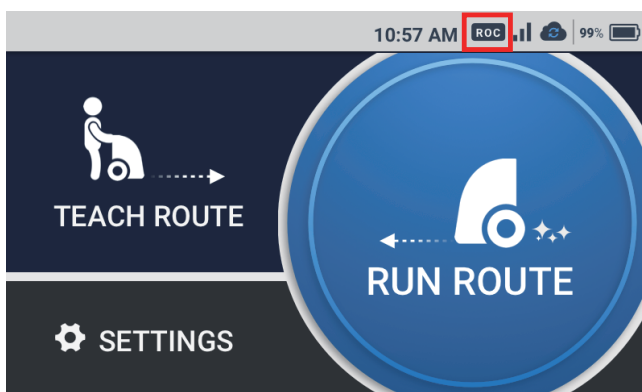

- Please check your mobile phone cellular connection in advance. Robot Operations Center (ROC) will not be connected to 4G (LTE) in an area where there is no signal.
- The connection status to the ROC will be shown by the ROC indicator on the display (see Whiz Operational Manual " Touch Display")

**3** Press the button on the notification pager for at least 5 seconds.

---

 The message “Wireless connection in process”  will be shown on the pager's display.

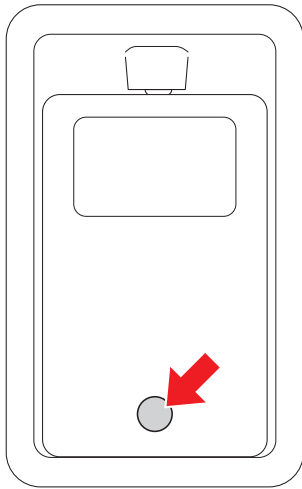

**4** Attach the pager onto the pager holder on the side of the machine.

---

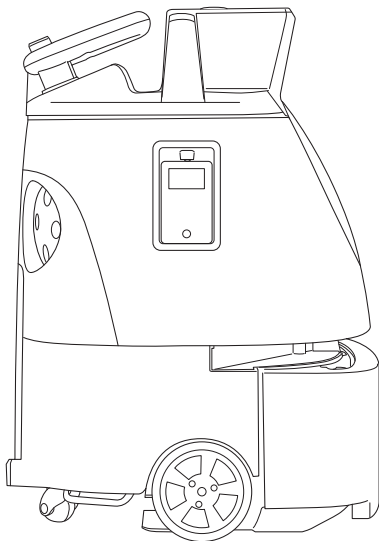

- Carry out autonomous cleaning and check if you will receive the alerts (see Whiz Operational Manual “Carrying Out Autonomous Cleaning”).



## 1-4.Recharging the Notification Pager

If notification pager battery is running low, charge the pager fully before using it.

**1** Insert the Micro USB plug to the cable in the terminal on the back of the notification pager charger.

---

**2** Connect the USB plug to the cable in USB AC adapter, and plug the adapter into an outlet.

---

The customer must purchase a USB AC adapter themselves.

**3** Place the notification pager in its charger.

---

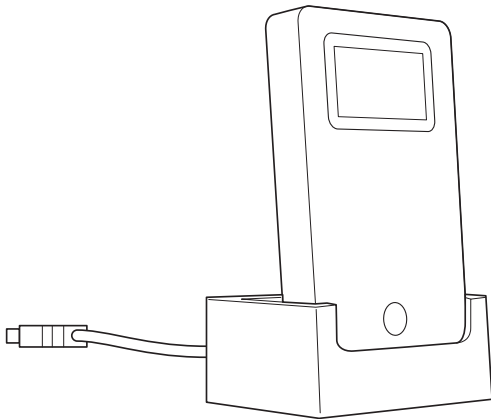

- An AC adapter is not included in the product package. The customer must use their own AC adapter.
- Press the pager main button, and if the fully charged mark  appears on the display, it has completed charging.
- About 2.5 hours are required to fully recharge.

## 2. Safety Warnings

---

### 2-1.About Safety Warnings

IMPORTANT SAFETY INFORMATION: READ AND UNDERSTAND THESE SAFETY WARNINGS AND ALL INSTRUCTIONS PRIOR TO UNPACKING AND USING THE MACHINE.

Warnings presented here are intended to warn the user of potential harm to the user and other people as well as damage to property. Always adhere to them to reduce the potential for harm. This manual also provides safety warnings, correct handling procedures, and other regulatory information for using the machine, notification pager, battery, and battery charger. Warnings provided in this manual do not cover all possible situations that may arise. Safety of the pedestrians and people in the surrounding will be the first priority in any circumstances (such as when the machine does not operate properly, when the machine has tripped over, etc.).



Always adhere to warnings regarding machine installation, maintenance, and use and store this manual where it can always be referred to.

In the following emergencies, immediately press the emergency stop button and turn off the main power switch.

- The machine is in a hazardous state (example: emitting smoke, is inoperable, has fallen over, etc.)
- The machine comes close to inflicting harm on surrounding people or things.
- The machine is operating (behaving) unpredictably or is operating in a manner that is inconsistent with this manual.





## 2-2. Description of Symbols

The following symbol categories explain the level of harm or damage that can occur if warnings are not observed and the machine or related equipment is used incorrectly. Please be sure you understand these symbols and their correlating meanings before reading the remainder of this manual.

 <b>DANGER</b>	Indicates a hazardous situation that, if not avoided, will result in death or serious injury.
 <b>WARNING</b>	Indicates a hazardous situation that, if not avoided, could result in death or serious injury.
 <b>CAUTION</b>	Indicates a hazardous situation that, if not avoided, could result in minor or moderate injury.
<b>NOTE</b>	Indicates the caution item that may cause failure or damage to the equipment when mishandled.

## 2-3. Description of Pictorial Indications

The following pictorial indication categories explain information to be observed. Read this guide after thoroughly understanding the information.

	Prohibited (not allowed) action.		Compulsory action based on instruction (must be performed).
	Must not be used where exposed to water, and must not be splashed with water.		Unplug the power plug from the outlet.

## 2-4. Handling the Notification Pager



### DANGER



**Do not drop or throw.**

Subjecting it to strong impact may cause the battery pack in the notification pager to leak, overheat, rupture, or ignite, and otherwise result in injury, electric shock, damage, malfunction, overheating, leakage, chemical explosion, or other damage to the machine, battery charger, battery or notification pager.



### WARNING



**Do not place the notification pager or the notification pager charger inside a heating cooker such as a microwave oven or a high-pressure container such as a pressure cooker, or place on top of an electromagnetic cooker (IH cooker).**

Doing so may cause leakage, overheating, explosion, or ignition of the battery pack inside the notification pager, or overheating, smoking, ignition, or failure of the notification pager or the notification pager charger.



**Store out of the reach of infants, children, and pets.**

Failure to do so may present a choking hazard or other risk of physical injury or death of infants, children, and pets.



**If prolonged contact with the notification pager causes skin irritation (itchiness, rash, eczema, etc.), immediately discontinue use and consult a doctor.**

## 2-5. Handling near Electronic Medical Devices



### DANGER



**If wearing an implanted cardiac pacemaker or implanted defibrillator, consult with the manufacturer of such medical device to confirm a safe operational distance from the machine.**

Electric signals may affect the operation of the pacemaker or defibrillator.





**Do not use in a healthcare environment or near electronic medical devices.**

\* The machine does not comply with UL or IEC 60601 standards (or equivalent standards).

## 2-6.Pictorial Symbols

Refer to the labels on each product (the machine, battery charger, battery).

	Do not short-circuit.		Do not disassemble.
	Do not immerse in water or other liquid.		

## 2-7.Machine Disposal and Recycling

This product is designed and manufactured with recyclable, high-quality materials and components. When disposing of the machine, check that it is being disposed of properly as industrial waste differentiated from general and business waste according to regional and municipal regulations by request to an industrial waste disposal operator.

\* If the machine is being leased, it cannot be disposed of by yourself. Contact customer support (cc@icerobo.com). When disposing of the machine, remove the battery from the machine, and dispose of properly according to regulations for waste disposal in the region you are residing in.

The full text of the EU declaration of conformity is available at [meetwhiz.com/certification](https://meetwhiz.com/certification)

