



IM#: 16-0014627

**CF Series Monitor Arm**  
versatile technology supports

**Steelcase**  
WORKTOOLS



IM#: 17-0078700

## Productivity + Wellbeing

Workers spend upward of seven hours each day viewing screens. As mobile devices continue to evolve and shrink, it's challenging to find ergonomic viewing solutions that suit everyone. CF Series monitor arms enhance wellbeing and increase productivity by elevating up to six monitors, offering flexible supports for laptops and tablets, and giving workers choice and control over how they work.

## Personalized Monitor Display

For single, dual or triple monitors—displayed side by side or stacked—the CF Series arms secure screens in the optimal position, giving workers total access to a range of information without sacrificing wellbeing. Bring monitors closer for detailed work or move them farther away with the touch of a hand, without altering the height or angle of the screens.



IM#: 17-0078707

### ADAPTABLE SUPPORT

Easily adapt any workspace to fit varied workstyles with the Laptop Holder or Universal Laptop/Tablet Holder. And with modular extenders, workers go from viewing one to up to six monitors effortlessly.



IM#: 17-0078711

## STATEMENT OF LINE

All arms include VESA plates and cable management, can rotate 360°, and can be set in portrait or landscape positions.

### MONITOR ARM ASSEMBLIES

All assemblies include pole- and mounting-bracket options, unless stated otherwise. Bracket options include desk-clamp/grommet/through-mount, BIVI, c:scape and FrameOne. Arms are shown with desk-clamp bracket.

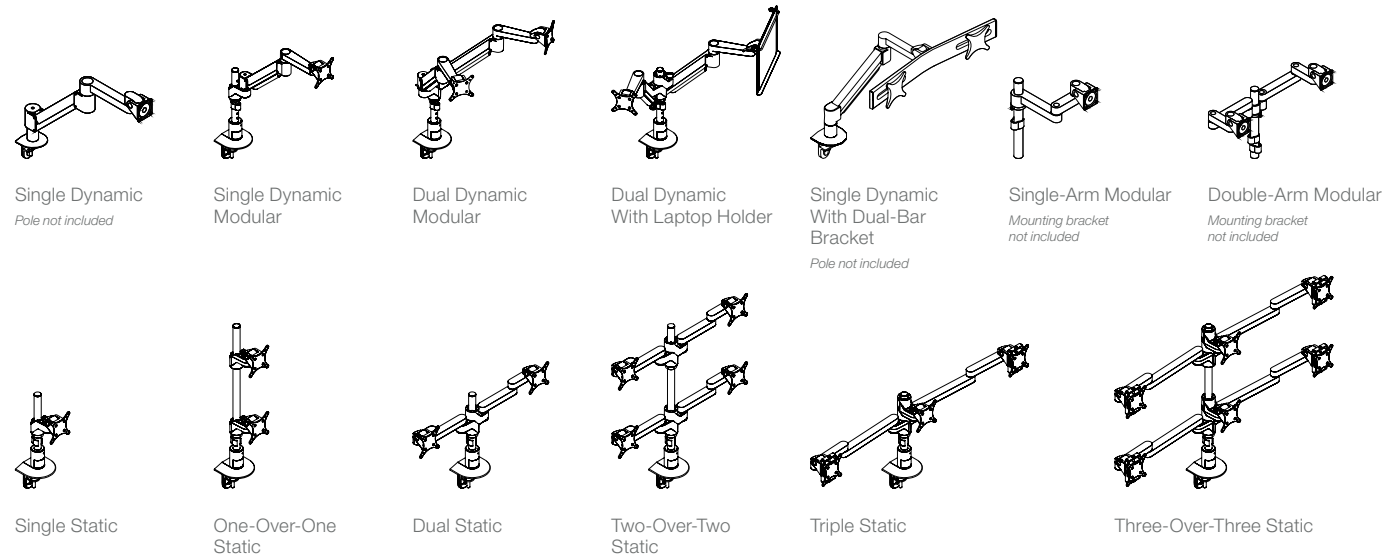

### ARMS, CONNECTORS, EXTENDERS AND POLES

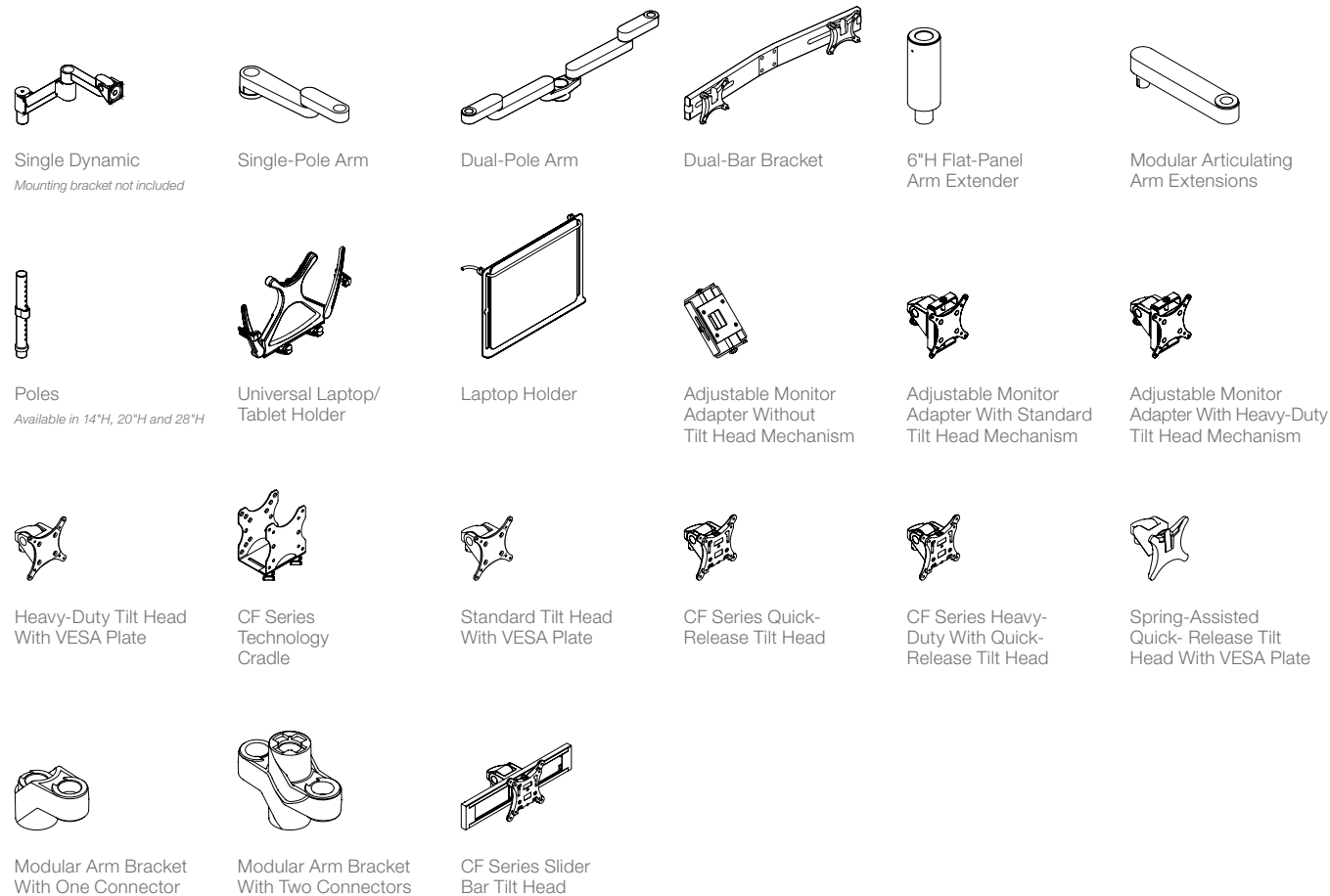

## STATEMENT OF LINE

### BRACKETS AND MOUNTS

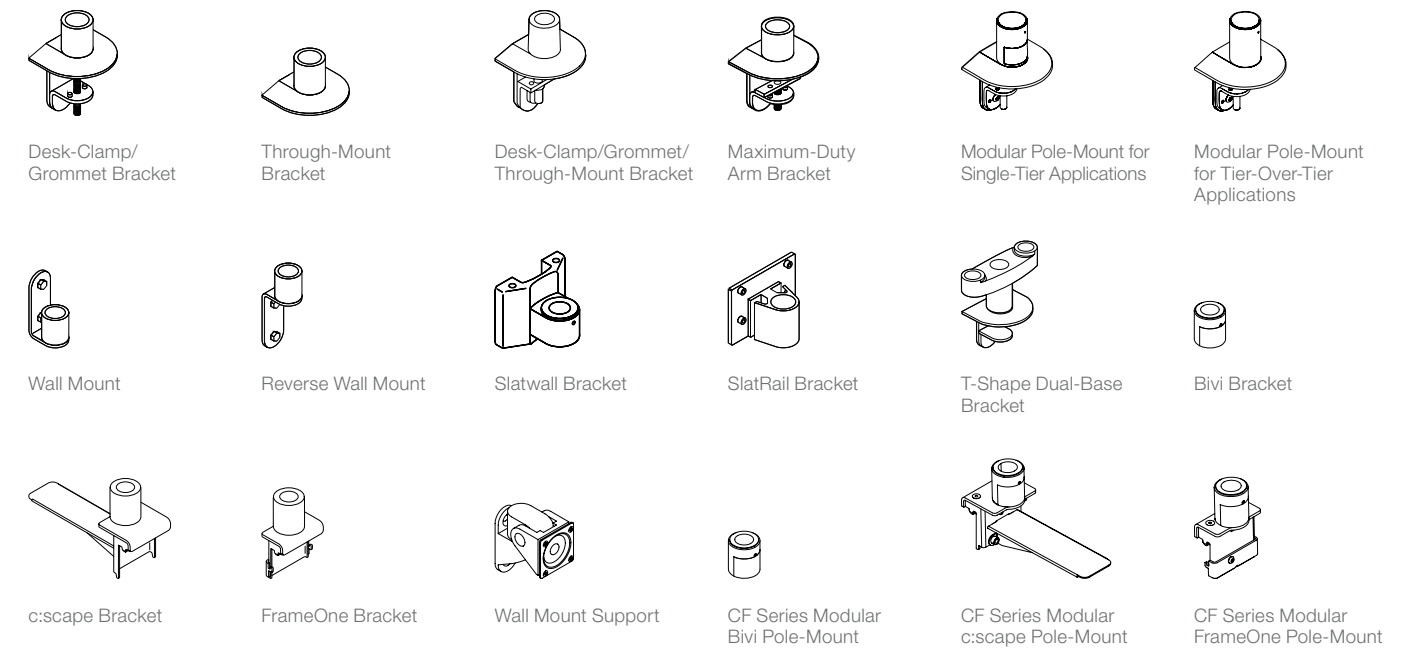

*Note: Not all brackets and mounts are compatible. Refer to the Steelcase Worktools Specification Guide for compatibilities and restrictions.*

### SURFACE MATERIALS

Surface materials shown in brochure:

- 0835 Black
- ZW01 Pearl Snow
- 7018 Pewter

Colors are representative and may vary slightly from actual material.

For further options, visit us online.

### SUSTAINABILITY

At its heart, sustainability at Steelcase is about people. It's about creating and supporting the economic, environmental and social conditions that allow people and communities to reach their full potential.

**Research and insights direct our path.** It's not only about creating goods, it's about creating good. It's not only about creating value, it's about living our values. It's not just about reducing our footprint, it's about expanding our reach. It's about creating lasting and meaningful change to enable the long-term wellbeing of current and future generations.

**Innovative products and solutions result.** In the development of our products, we work to consider each stage of the life cycle: from materials extraction, production, transport, use and reuse, until the end of its life. We demonstrate performance through third-party verified certifications and voluntary product declarations.

Steelcase's sustainability promises, actions, and results are communicated in an annual Corporate Sustainability Report.

**Steelcase®**

**Call 800.333.9939 or visit [Steelcase.com](https://www.steelcase.com)**

 [facebook.com/Steelcase](https://www.facebook.com/Steelcase)

 [twitter.com/Steelcase](https://twitter.com/Steelcase)

 [youtube.com/SteelcaseTV](https://www.youtube.com/SteelcaseTV)

Item #19-0000245 3/19 ©2019 Steelcase Inc. All rights reserved. All specifications subject to change without notice. Trademarks used herein are the property of Steelcase Inc. or of their respective owners. Printed in U.S.A. FSC certified.